

Synchro

E X C I T E +

SERVICE & MAINTENANCE MANUAL

REV. 7.1



The information contained in this manual is intended for **QUALIFIED TECHNICIANS** who have completed a specific **TECHNOGYM** training course and are authorized to perform machine start-up and adjustment procedures as well as extraordinary maintenance or repairs which require a thorough knowledge of the machine, its operation, its safety devices and working procedures.

**CAREFULLY READ THE INFORMATION CONTAINED IN
THIS MANUAL BEFORE PERFORMING ANY MAINTENANCE
PROCEDURES ON THE MACHINE**



**DANGEROUS VOLTAGES
PRESENT**

NOTE:

The information contained in this document is subject to change without notice.

Technogym does not guarantee this documentation in any way. Technogym shall not be held responsible for any errors contained in this manual and declines all liability for accidents or damages resulting from the supply, characteristics or use of this manual.

This document contains proprietary information that is protected by copyright. All rights reserved. No part of this document may be photocopied, reproduced or translated into another language without the prior written consent of Technogym.

The Technogym™ trademark is property of Technogym S.p.A.
Synchro Excite +™ è un marchio di proprietà di Technogym S.p.A.

Contents

1. GENERAL NOTICES	1.1
1.1. INTRODUCTION.....	1.1
1.2. RECOMMENDATIONS	1.1
1.3. GENERAL RULES FOR REPAIR PROCEDURES	1.2
2. TECHNICAL SPECIFICATIONS.....	2.1
2.1. PRODUCT CODES	2.1
2.2. SERIAL NUMBER STRUCTURE	2.3
2.3. COLOUR OPTIONS	2.3
2.4. PRODUCT CHARACTERISTICS	2.4
2.5. MECHANICAL CHARACTERISTICS	2.5
2.5.1. Overall dimensions.....	2.5
2.5.2. European and overseas packing dimensions.....	2.6
2.6. AMBIENT SPECIFICATIONS	2.7
2.7. CONFORMITY TO REGULATIONS	2.7
2.8. WIRING DIAGRAMS	2.8
2.8.1. Powered model 500 (ARM Board).....	2.8
2.8.2. Self-Powered model 500SP (ARM Board)	2.9
2.8.3. Powered model 700 (ARM Board).....	2.10
2.8.4. Self-Powered model 700SP (ARM Board)	2.11
2.8.5. Powered model 700VISIO (CPU Board).....	2.12
2.9. CABLES	2.13
2.9.1. CBQ cables.....	2.13
2.9.2. Cavi CU2.14	
2.9.3. Cavi ELT.....	2.15
3. PRINCIPLES OF OPERATION.....	3.1
3.1. BLOCK DIAGRAM.....	3.1
3.2. LED DISPLAY BOARDS.....	3.2
3.2.1. ARM Board: 500 and 500SP models.....	3.2
3.2.2. ARM Board: 700 and 700SP models.....	3.3
3.2.3. C-Safe board	3.3
3.2.4. Dual TGS reader.....	3.3
3.3. VISIO DISPLAY BOARD	3.4
3.3.1. CPU Board: 700VISIO model.....	3.4
3.3.1.1. Back-Up battery.....	3.4
3.3.2. LCD inverter	3.5
3.3.3. Digital/Analogue tuner board.....	3.5
3.3.4. Integrated LAN network board (Wired).....	3.5
3.3.5. Wireless network board (without cables).....	3.6
3.3.6. Audio/Video external device connector board	3.7
3.3.7. Headphone jack.....	3.7
3.3.8. C-Safe board (integrated)	3.7
3.3.9. Service USB port (integrated).....	3.7
3.3.10. Optional Accessories.....	3.8
3.3.10.1. iPod docking station	3.8
3.3.10.2. Client USB port	3.8
3.3.10.3. Dual TGS reader	3.8
3.4. CARDIO RECEIVER BOARD.....	3.9
3.4.1. HS (Hand Sensor).....	3.9
3.4.2. HR (Chest Belt)	3.10
3.5. BRAKE BOARD	3.11
3.6. ELECTROMAGNETIC BRAKE	3.12

3.7. SPEED SENSOR	3.12
3.8. POWER ENTRY MODULE	3.13
3.9. ALTERNATOR	3.13
3.10. BATTERY	3.14
3.11. EXTERNAL POWER SUPPLY INPUT	3.14
3.12. BRAKE CONTROL	3.15
3.12.1. Mechanics	3.15
3.12.2. Controls	3.15
3.12.3. The signals involved	3.17
4. ACCESSORIES.....	4.1
4.1. CARDIO THEATER CONNECTION	4.1
4.2. PC LINK FOR PROGRAMMING	4.2
4.3. MONITOR PLUG FOR C-SAFE PORT	4.3
4.4. VISIOWEB UPGRADE.....	4.3
4.4.1. VISIO vs VISIOWEB	4.3
4.4.2. VISIOWEB upgrade for VISIO models.....	4.3
4.4.3. UpGrade from LED to VisioWEB	4.4
4.5. ACCESSORISE	4.4
5. INSTALLATION INSTRUCTIONS	5.1
5.1. SPECIFICATIONS AND REQUIREMENTS	5.1
5.2. MOVING THE EQUIPMENT	5.2
5.3. RECOMMENDED ANTENNA SIGNAL REQUIREMENTS	5.3
5.4. INSTALLATION	5.4
5.5. FIRST POWER-ON	5.4
6. TROUBLESHOOTING.....	6.1
6.1. TROUBLESHOOTING MENU: LED MODELS	6.2
6.1.1. Accessing configuration of 500 models.....	6.2
6.1.2. Accessing configuration of 700 models.....	6.2
6.1.3. Automatic Test.....	6.3
6.1.3.1. I2C Devices Test.....	6.3
6.1.3.2. LED Test.....	6.4
6.1.3.3. Serial Ports Test	6.4
6.1.4. Manual Test.....	6.4
6.1.4.1. Man. Keyboard Test.....	6.4
6.2. TROUBLESHOOTING MENU: VISIO MODEL	6.5
6.3. THE DISPLAY FAILS TO ILLUMINATE	6.6
6.3.1. LED models	6.6
6.3.2. SP models	6.8
6.3.2.1. The Display does not illuminate.....	6.8
6.3.2.2. The Display doesn't remain on when stopping the execution of the exercise	6.10
6.3.3. VISIO models	6.12
6.4. THE TOUCH SCREEN DOES NOT WORK / IT'S NOT CALIBRATED	6.16
6.5. NO AUDIO SOUND	6.16
6.6. NO TV PICTURE.....	6.16
6.7. THE RADIO DOES NOT PLAY	6.16
6.8. THE IPOD DOES NOT WORK	6.17
6.9. MESSAGE ON DISPLAY "THE EQUIPMENT IS LOCKED (COM)"	6.19
6.10. THERE IS NO RESISTANCE	6.20
6.11. THE RESISTANCE IS INCORRECT	6.22
6.12. THE SPEED SIGNAL IS INCORRECT	6.24
6.13. THE MACHINE DOES NOT READ THE TGS.....	6.26
6.14. THERE IS NO HEART RATE SIGNAL.....	6.28
6.14.1. HS receiver (Hand sensor).....	6.28
6.14.2. HR receiver (Chest Belt)	6.31
6.15. THE TELEMETRIC HEART RATE SIGNAL IS INCORRECT	6.34
6.15.1. Chest Belt	6.34
6.15.2. Hand Sensor.....	6.38

7. DISASSEMBLY OF COMPONENTS	7.1
7.1. DISASSEMBLING THE DISPLAY	7.1
7.1.1. 500 and 500SP version.....	7.1
7.1.2. 700 and 700SP version.....	7.2
7.1.3. 700VISIO version.....	7.3
7.2. DISASSEMBLING BOARDS AND COMPONENTS.....	7.4
7.2.1. LED Display (ARM Board).....	7.4
7.2.1.1. ARM board (A).....	7.5
7.2.1.2. C-Safe board (B).....	7.6
7.2.2. VISIO Display 15" (CPU Board).....	7.7
7.2.2.1. Wireless board (A).....	7.8
7.2.2.2. Tuner DVB-T board (B).....	7.10
7.2.2.3. Tuner board ATSC (B1) and ISDB-T (B2).....	7.11
7.2.2.4. LCD Inverter (C).....	7.12
7.2.2.5. CPU board (D).....	7.13
7.2.2.6. LCD (E) + Touch Screen.....	7.14
7.2.2.7. Headphone Jack (F).....	7.15
7.2.2.8. Dual TGS reader + USB port (G).....	7.16
7.2.2.9. iPod Docking Station (H).....	7.17
7.2.2.10. Frontal plugs TGS + USB and cover.....	7.18
7.3. DISASSEMBLING THE KEYBOARD / TOUCH SCREEN	7.19
7.3.1. LED Keyboard.....	7.19
7.3.2. VISIO version.....	7.21
7.4. DISASSEMBLING THE CARDIO RECEIVER	7.22
7.5. DISASSEMBLING THE FIXED HANDGRIPS.....	7.24
7.6. DISASSEMBLING THE HAND SENSOR	7.26
7.7. DISASSEMBLING THE GUARDS.....	7.28
7.7.1. Rear guard	7.28
7.7.2. Brake box cover guard.....	7.30
7.7.3. Front guards.....	7.31
7.8. DISASSEMBLING THE LEVERS.....	7.32
7.9. DISASSEMBLING THE BRAKE BOX	7.34
7.10. DISASSEMBLING THE HAND SENSOR.....	7.35
7.11. DISASSEMBLY THE PRIMARY SHAFT AND PULLEY	7.36
7.12. DISASSEMBLING THE PLATFORM LEVER	7.41
7.13. DISASSEMBLING THE BRAKE WINDING.....	7.46
7.14. DISASSEMBLING THE FLYWHEEL AND BETL TENSIONER	7.47
7.14.1. Powered models	7.47
7.14.2. Self-powered models	7.49
7.15. DISASSEMBLING THE SPEED SENSOR	7.51
7.16. DISASSEMBLING THE BATTERY	7.52
7.17. DISASSEMBLING THE FOOTBOARDS, POWER ENTRY MODULE AND WHEELS	7.53
8. ADJUSTMENT	8.1
8.1. BELT TENSION	8.1
8.2. SPEED SENSOR POSITIONING	8.2
8.3. BRAKE WINDING POSITIONING	8.3
8.4. THE MACHINE IS NOT FLAT	8.4
9. MACHINE CONFIGURATION	9.1
9.1. USER MENU CONFIGURATION: 500LED MODELS	9.1
9.1.1. Language.....	9.2
9.1.2. Units of measurement.....	9.2
9.1.3. Maximum exercise time	9.2
9.1.4. Pause time	9.3
9.1.5. Cooldown time.....	9.3
9.1.6. Default age.....	9.3
9.1.7. Default weight.....	9.4
9.1.8. Default duration.....	9.4
9.1.9. Default calories.....	9.4

9.1.10. Default distance.....	9.5
9.1.11. Enable TGS	9.5
9.1.12. Enable keyboard.....	9.5
9.1.13. Modifiable target frequencies	9.6
9.1.14. Enable custom messages	9.6
9.1.15. Resetting parameters to default values.....	9.6
9.1.16. Format P&P key.....	9.7
9.1.17. SN	9.7
9.2. USER MENU CONFIGURATION: 700LED MODELS	9.8
9.2.1. Language.....	9.9
9.2.2. Distance.....	9.9
9.2.3. Maximum exercise time	9.9
9.2.4. Pause time	9.9
9.2.5. Cooldown time.....	9.10
9.2.6. Enable TGS	9.10
9.2.7. Enable keyboard.....	9.10
9.2.8. Modifiable target heart rate	9.11
9.2.9. Enable custom messages	9.11
9.2.10. Edit custom messages.....	9.11
9.2.11. Change messages languages	9.11
9.2.12. Enable multi-language mode	9.12
9.2.13. Resetting parameters to default values.....	9.12
9.2.14. Format P&P.....	9.12
9.2.15. SN	9.12
9.3. SERVICE MENU CONFIGURATION: LED MODELS	9.13
9.3.1. Accessing configuration of 500 models.....	9.13
9.3.2. Accessing configuration of 700 models.....	9.13
9.3.3. Low kit parameter	9.15
9.3.3.1. Read from low kit	9.15
9.3.3.2. Write to low kit	9.15
9.3.3.3. Default Setting.....	9.16
9.3.3.4. Table of configuration parameters:	9.16
9.3.4. Operating data	9.17
9.3.4.1. Read from low kit	9.17
9.3.4.2. Write to low kit	9.18
9.3.4.3. Machine usage data.....	9.18
9.3.5. Errors log	9.19
9.3.5.1. Read from low kit	9.19
9.3.5.2. Reset Errors.....	9.19
9.3.5.3. COM.Fault	9.20
9.3.5.4. View Errors.....	9.20
9.3.6. Standard settings.....	9.21
9.3.7. Low kit menu	9.21
9.3.7.1. Low kit version	9.21
9.3.7.2. Low Kit fault code	9.22
9.3.8. High kit version	9.22
9.3.9. BOOT version.....	9.22
9.3.10. Key Reader Version.....	9.22
9.4. CONFIG.: VISIO - VISIOWEB USER MENU.....	9.23
9.5. SERVICE MENU CONFIG.: VISIO - VISIOWEB.....	9.24
9.5.1.1. Table of configuration parameters	9.25
10. UPDATING THE SW.....	10.1
11. FUNCTIONAL TEST MD MODELS.....	11.1
11.1. ELECTRICAL SAFETY TEST	11.1
11.2. MECHANICAL TESTING OF SECURITY	11.3
11.2.1. Checking the assembly of the transmission and levers systems.....	11.3
11.2.2. Checking the assembly of the guards	11.3
11.3. START-UP CHECK.....	11.3
11.4. LIST OF CRITICAL SPARE PARTS.....	11.4



12. SCHEDULED MAINTENANCE	12.1
12.1. ORDINARY MAINTENANCE OPERATION.....	12.2
12.1.1. <i>Setting up the operation (Daily)</i>	12.2
12.1.2. <i>External cleaning operations (Daily)</i>	12.2
12.1.3. <i>Internal cleaning operations (Monthly)</i>	12.2
12.1.4. <i>Complete operation (six-monthly)</i>	12.2
12.2. EXTRA-ORDINARY MAINTENANCE OPERATIONS	12.3
12.2.1. <i>Checking the working conditions</i>	12.3
12.2.2. <i>Checking the operation of the Cardio Receiver</i>	12.3
12.2.3. <i>Checking the operation of the hand sensor receiver</i>	12.3
12.2.4. <i>Checking the amount of play on the ball joints</i>	12.3
12.2.5. <i>Checking the wear of rubber parts</i>	12.3
12.2.6. <i>Checking the belts</i>	12.3
12.2.7. <i>Checking the play of the lever and pedal group</i>	12.3
12.2.8. <i>Checking the display</i>	12.4
12.2.9. <i>Checking the wiring and connections</i>	12.4
13. APPENDIX.....	13.1
13.1. PASSWORD MENUTABLE	13.1
13.2. REQUIRED TOOLS.....	13.2

Page intentionally left blank.

1. GENERAL NOTICES

1.1. INTRODUCTION

This document is reserved for Technogym Service technicians, and is intended to provide authorized personnel with the necessary information to correctly carry out repairs and maintenance. A thorough knowledge of the technical information contained in this manual is essential for completing the professional training of the operator.

In order to facilitate consultation, the paragraphs are accompanied by schematic drawings which illustrate the procedure being described.

This manual contains notices and symbols which have a specific meanings:



WARNING: non observance may result in accident or injury.



CAUTION: non observance may cause damage to the machine.



Information about the operation in progress.



Observation about the operation in progress.


1.2. RECOMMENDATIONS

Technogym recommends the following steps for planning repair procedures:

- Carefully evaluate the customer's description of the machine malfunction and ask all the necessary questions to clarify the symptoms of the problem.
- Clearly diagnose the causes of the problem. This manual provides the fundamental theoretical basis, which must then be integrated by personal experience and attendance at the training courses periodically offered by Technogym.
- Rationally plan the repair procedure so as to minimize the downtime necessary for procuring spare parts, preparing tools, etc.
- Access the component to be repaired, avoiding any unnecessary operations. In this regard it will be useful to refer to the disassembly sequence described in this manual.

1.3. GENERAL RULES FOR REPAIR PROCEDURES

1. Always mark any parts or positions which may be confused with each other at the time of reassembly.
2. Use original Technogym spare parts and lubricants of the recommended brands.
3. Use special tools where specified.
4. Consult the Technical Newsletters, which may contain more up-to-date information on adjustments and maintenance than those contained in this manual.
5. Before starting the repair procedure, make sure that the recommended tools are available and in good condition.
6. For the procedures described in this manual, use only the specified tools.


 **The tool sizes quoted in this manual are expressed in mm.**

2. TECHNICAL SPECIFICATIONS


2.1. PRODUCT CODES

The machine codes take into account all the possible variants and options available for the products. The machine code, which does not include the *Serial Number*, consists of 16 alphanumeric characters arranged as follows:

Characters	Description	Key to values
1,2,	<i>Line type</i>	DA = Excite +
3,	<i>Machine type</i>	5 = Synchro
4,	<i>Model,</i>	2 = 500 3 = 700
5,	<i>Type of power supply</i>	3 = multi-voltage 4 = self-powered M = Medical Device - CE
6,	<i>Type of Display</i>	L = LED W = VisioWEB Y = VisioWEB (Capacitive TS)
7,	<i>Integrated accessories</i>	N = None T = Wellness System I = iPod + USB A = iPod + USB + WS
8,9,	<i>Colour of the frame</i>	AL = Silver AN = Anthracite
10,11,	<i>Colour of upholstery</i>	00 = None AG = Grey K0 = Blue M0 = Bordeaux NA = Black Z0 = Brown
12,	<i>Guards colour</i>	G = Flint grey R = Renault grey
13,	<i>TV standard</i>	0 = nulla D = DVB-T A = ATSC / QAM-B I = ISDB-T

<i>Characters</i>	<i>Description</i>	<i>Key to values</i>
14,15,	Language,	00 = Multi-language BR = Portuguese CN = Chinese DA = Danish DE = German ES = Spanish FR = French IT = Italian JP = Japanese NL = Dutch RU = Russian TR = Turkish UK = British English US = American English
16.	Type of packing.	A, B, C, D, E, F, G, H, I, J, K, S, U  See the table below.

DA533WAAN00RD00E

 all of the Excite + line machines will be shipped with the specific power cable for the destination country. In particular this means a cable with the standard plug used in the installation country.

This implementation also means a change in the product code. Specifically the last character of the product code will be characterised based on the options shown in the table below:

16th Character Product code	Main country of use	Plug standard	Type of packaging
A	Australia	A S/NZS 3112	Overseas
B	Brazil	NBR 14136	Overseas
C	China	CPC S-CCC	Overseas
D	South Africa	SANS 164-2	Overseas
E	Europe (EC)	EEC 7/16	European
F	USA (UL 250 V)	NEMA 5-15/ NEMA 5-20	Overseas
G	Great Britain	BS1363	European
H	Argentina	IRAM 2073	Overseas
I	Italy	EEC 7/16	Italy
J	Japan	JIS 8303	Overseas
K	Great Britain	BS1363	Overseas
S	Europe (EC)	EEC 7/16	Overseas
U	USA (UL 110 V)	NEMA 6-15/ NEMA 6-20	Overseas

As shown in the table above, the 16th character also identifies the type of packaging depending on the destination country, i.e. **DA533WAAN00RD00E**.

2.2. SERIAL NUMBER STRUCTURE

The *Serial Number*, consists of 14 alphanumeric characters arranged as follows:

Characters	Description	key to values
1,2,3,4,5,6,	Product type,	DA5 = Synchro Excite +
		2 = 500
		3 = 700
		3 = multi-voltage 4 = self-powered M = Medical Device - CE
		L = LED W = VisioWEB Y = VisoWEB (Capacitive TS)
7,8,	Year of production,	10 = 2010
9,10,11,12,13,14.	Progressive.	000001

For example, a possible product code would be:

DA533W10000001

2.3. COLOUR OPTIONS

FRAME		UPHOLSTERY				
		NA. Black	Z0. Brown	M0. Bordeaux	K0. Blu	AG. Grey
AL. Silver (Metalized)		<input type="checkbox"/>	<input type="checkbox"/>	<input checked="" type="checkbox"/>	<input checked="" type="checkbox"/>	<input checked="" type="checkbox"/>
AN. Anthracite		<input checked="" type="checkbox"/>	<input checked="" type="checkbox"/>	<input type="checkbox"/>	<input type="checkbox"/>	<input type="checkbox"/>
GUARD						
R. Grey		<input checked="" type="checkbox"/>	<input checked="" type="checkbox"/>	<input type="checkbox"/>	<input type="checkbox"/>	<input type="checkbox"/>
G. Flint Grey		<input type="checkbox"/>	<input type="checkbox"/>	<input checked="" type="checkbox"/>	<input checked="" type="checkbox"/>	<input checked="" type="checkbox"/>

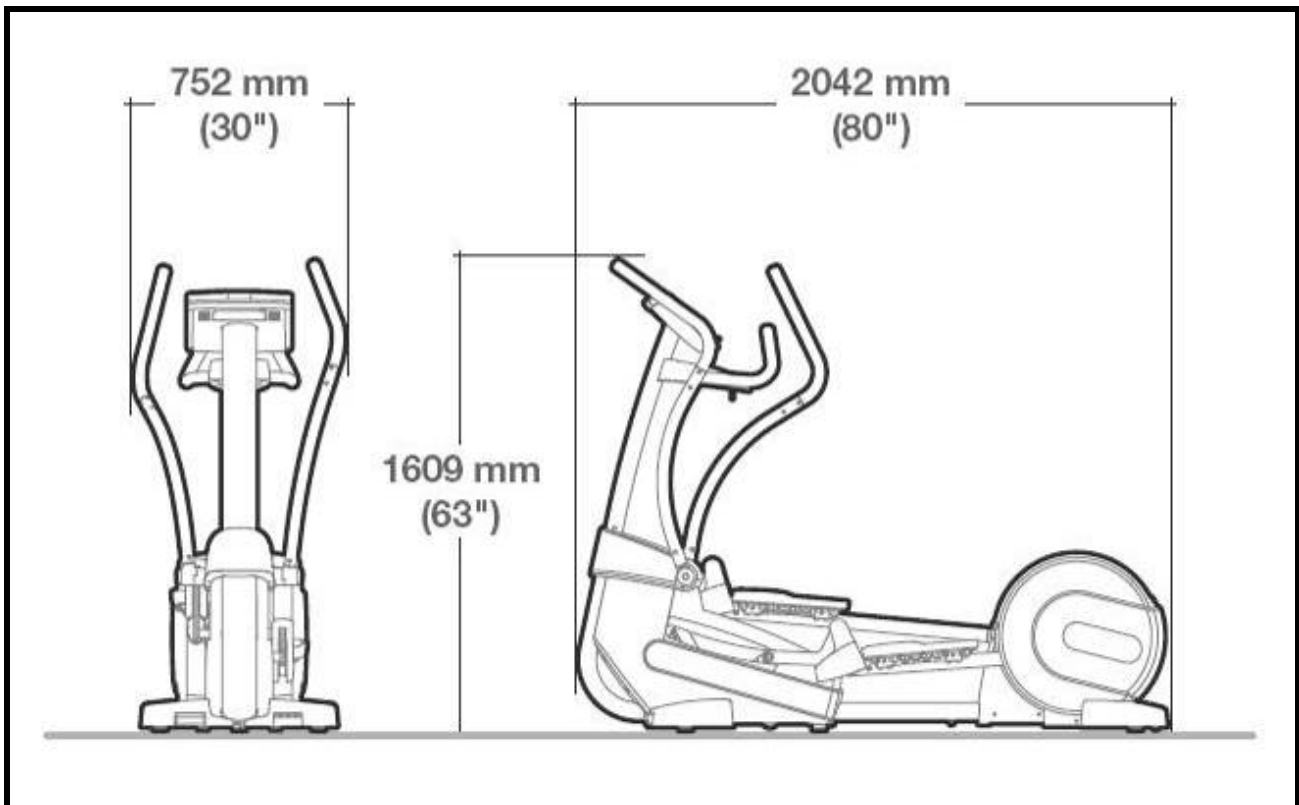
2.4. PRODUCT CHARACTERISTICS

MODELS					
	700VISIO	700	700SP	500	500SP
Power requirement:	<i>100-240Vac 50-60Hz</i>		<i>Self-Powered</i>	<i>100-240Vac 50-60Hz</i>	<i>Self-Powered</i>
Energy consumption:	<i>Max 75W (50VA)</i>	<i>Max 35W</i>	<i>NO</i>	<i>Max 35W (50VA)</i>	<i>NO</i>
Stand-by consumption:	<i>47W</i>	<i>9W</i>	<i>NO</i>	<i>9W</i>	<i>NO</i>
Resistance:	<i>30 – 500 Watt (a 70 rpm)</i>		<i>40 – 500 Watt (a 70 rpm)</i>	<i>30 – 500 Watt (a 70 rpm)</i>	<i>40 – 500 Watt (a 70 rpm)</i>
Difficulty level:	<i>1 - 25</i>				
Max user weight:	<i>180Kg – 397lbs</i>				
Fast Track Control:	<i>YES</i>			<i>NO</i>	
HR monitoring	<i>Double Hand sensor, Telemetry</i>			<i>Telemetry</i>	
Maintenance:	<i>Maintenance not required, software Serial upload</i>				
Goal oriented display:	<i>YES</i>				
Select language at the start of exercise:	<i>YES</i>			<i>NO</i>	
Plug & Play System:	<i>YES</i>				
Calorie Coach:	<i>YES</i>				
Total number of programs:	<i>23 Quick Start, Goals (Time, Distance, Calorie), CPR, Profiles (6 default, 9 custom), Custom, Training Zone, Weight Loss..</i>			<i>11 Quick Start, Goals (Time, Distance, Calorie), CPR, Profiles (6 default).</i>	
Sub-maximal Test	<i>Fitness test</i>			<i>NO</i>	
Wellness System:	<i>Optional</i>				
Language available:	<i>13 UK English, USA English, Italian, German, Spanish, French, Dutch, Portuguese, Japanese, Chinese, Russian, Turkish, Danish</i>				
93/42/CEE certification:	<i>NO</i>	<i>YES (700MD)</i>	<i>NO</i>	<i>YES (500MD)</i>	<i>NO</i>

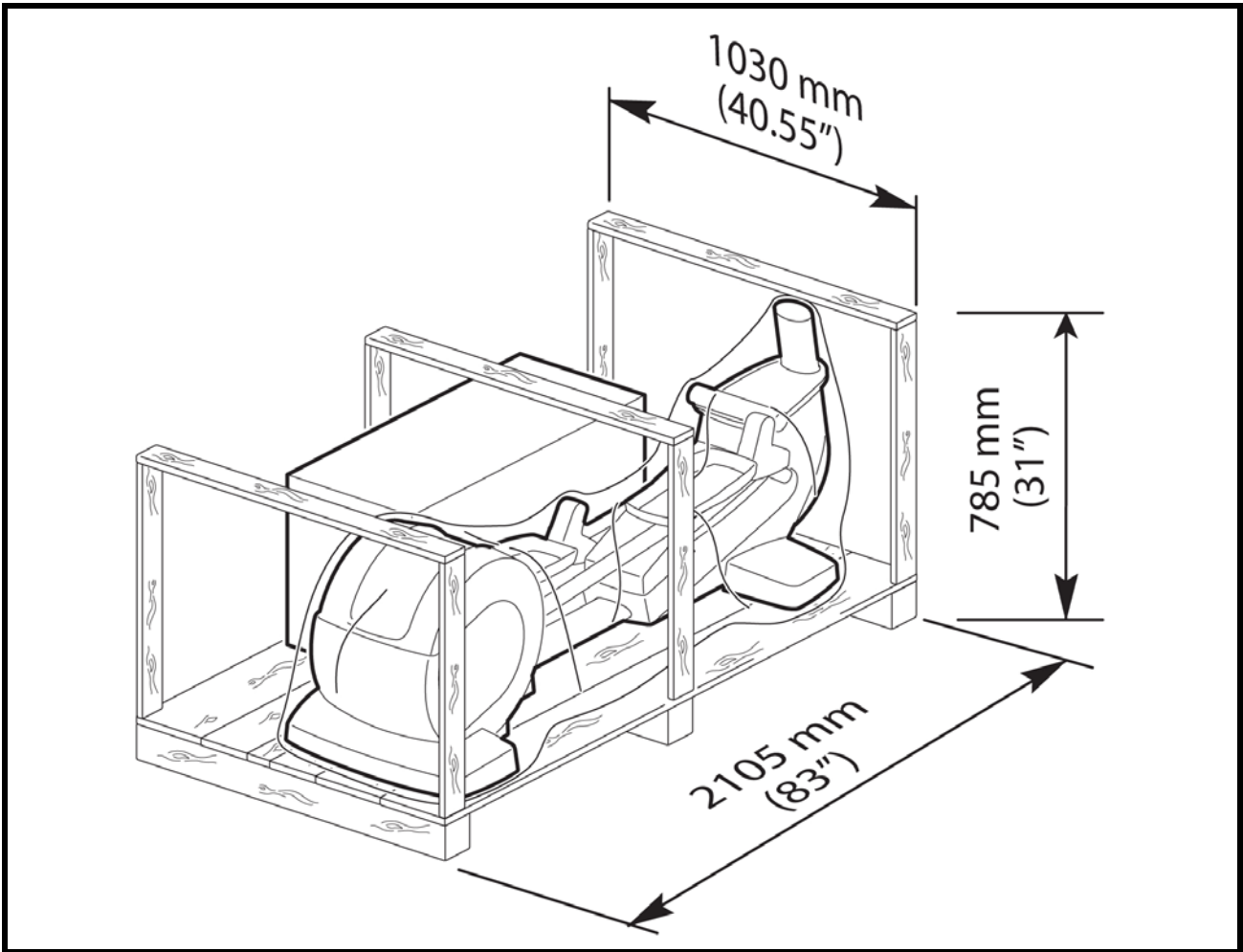
2.5. MECHANICAL CHARACTERISTICS

MECHANICAL CHARACTERISTICS	
Width (mm – in)	2042mm – 80”
Length (mm – in)	752mm – 30”
Height (mm – in)	1609mm – 63”
Weight (Kg – lbs)	150Kg – 331lbs

2.5.1. OVERALL DIMENSIONS



2.5.2. EUROPEAN AND OVERSEAS PACKING DIMENSIONS



2.6. AMBIENT SPECIFICATIONS

Temperature	<i>Operating</i>	<i>from 10° to 25° C</i>
	<i>Storage</i>	<i>from -10 to 70° C</i>
Humidity	<i>Operating</i>	<i>from 20% to 90% non-condensing</i>
	<i>Storage</i>	<i>from 20% to 90% non-condensing</i>

2.7. CONFORMITY TO REGULATIONS

The machine conforms to the following standards:

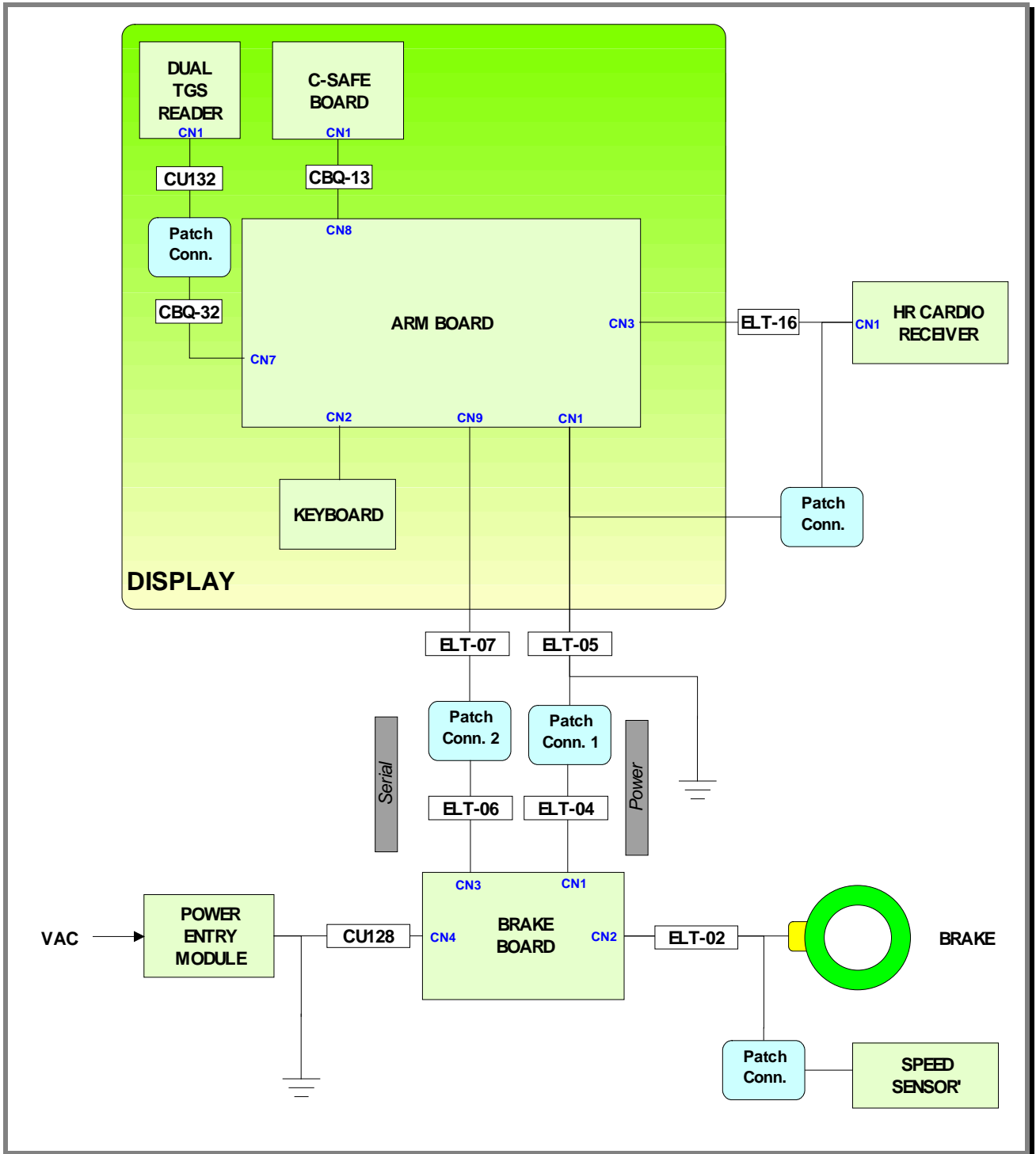
	EUROPA	USA
EMI	<i>EN 55014-1 (2008)</i> <i>EN 55014-2 (1998)</i> <i>EN 61000-3-2 (2007)</i> <i>EN 61000-3-3 (2009)</i>	<i>UL 1647</i>
Safety	<i>EN 60335-1 (2008)</i> <i>EN 957-1 (2006)</i> <i>EN 957-9 class SA (2009)</i>	
Directives	<i>2006/42/CE</i> <i>2004/108/CE</i> <i>2006/95/CE</i>	

Moreover:

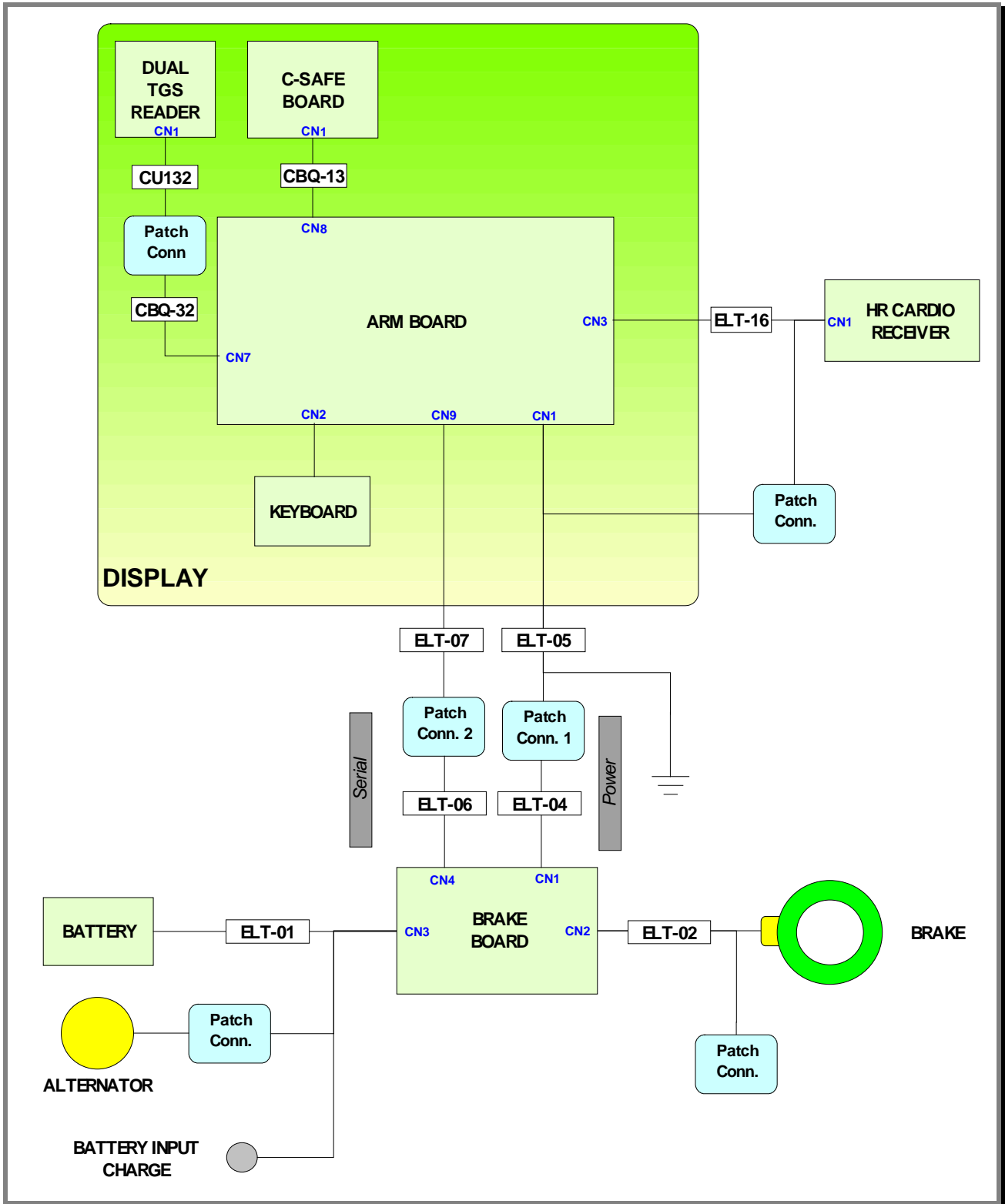
- *Electrical isolation class: Class I;*
- *Protection rating: IP20.*

2.8. WIRING DIAGRAMS

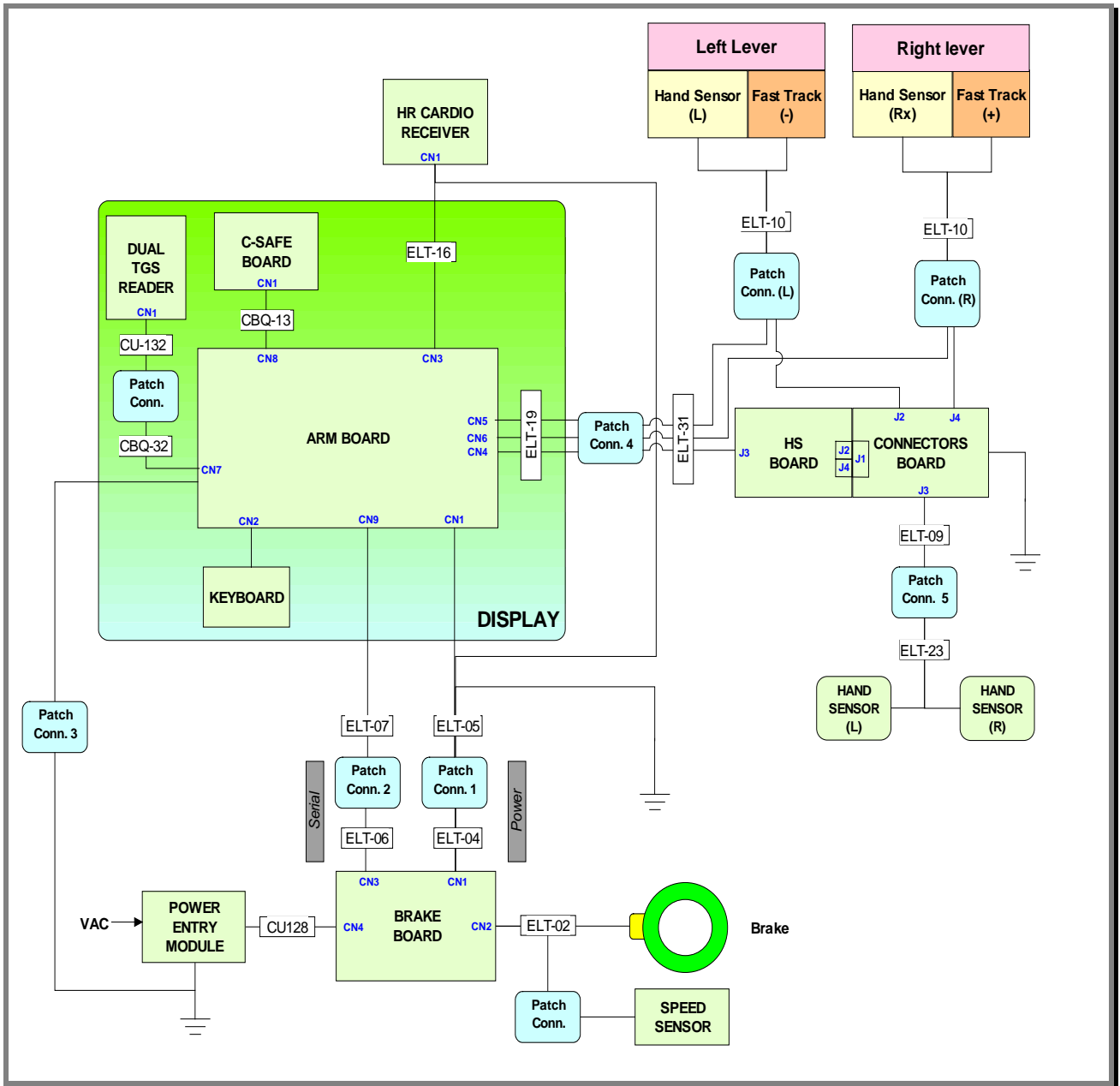
2.8.1. POWERED MODEL 500 (ARM BOARD)



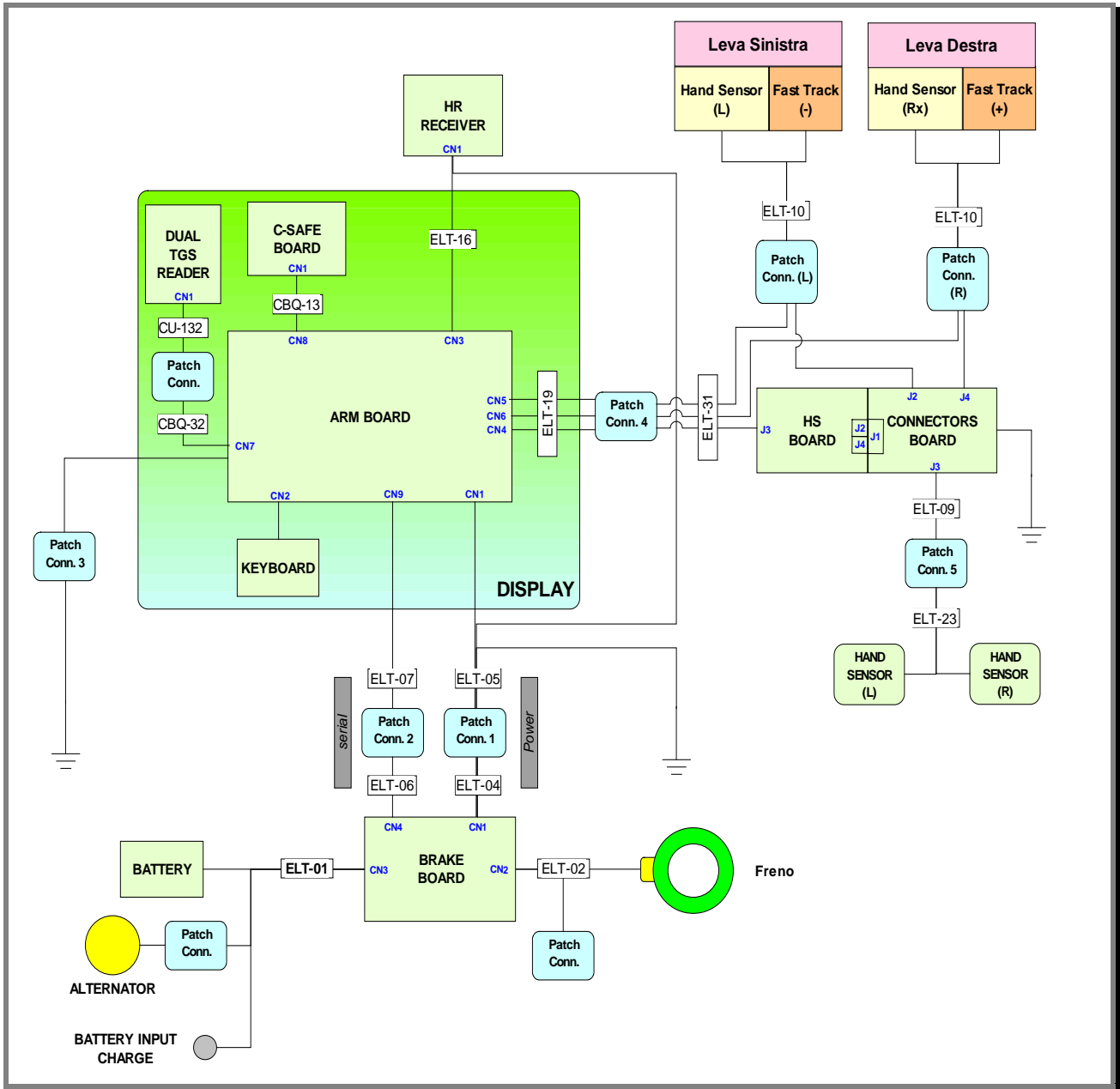
2.8.2. SELF-POWERED MODEL 500SP (ARM BOARD)



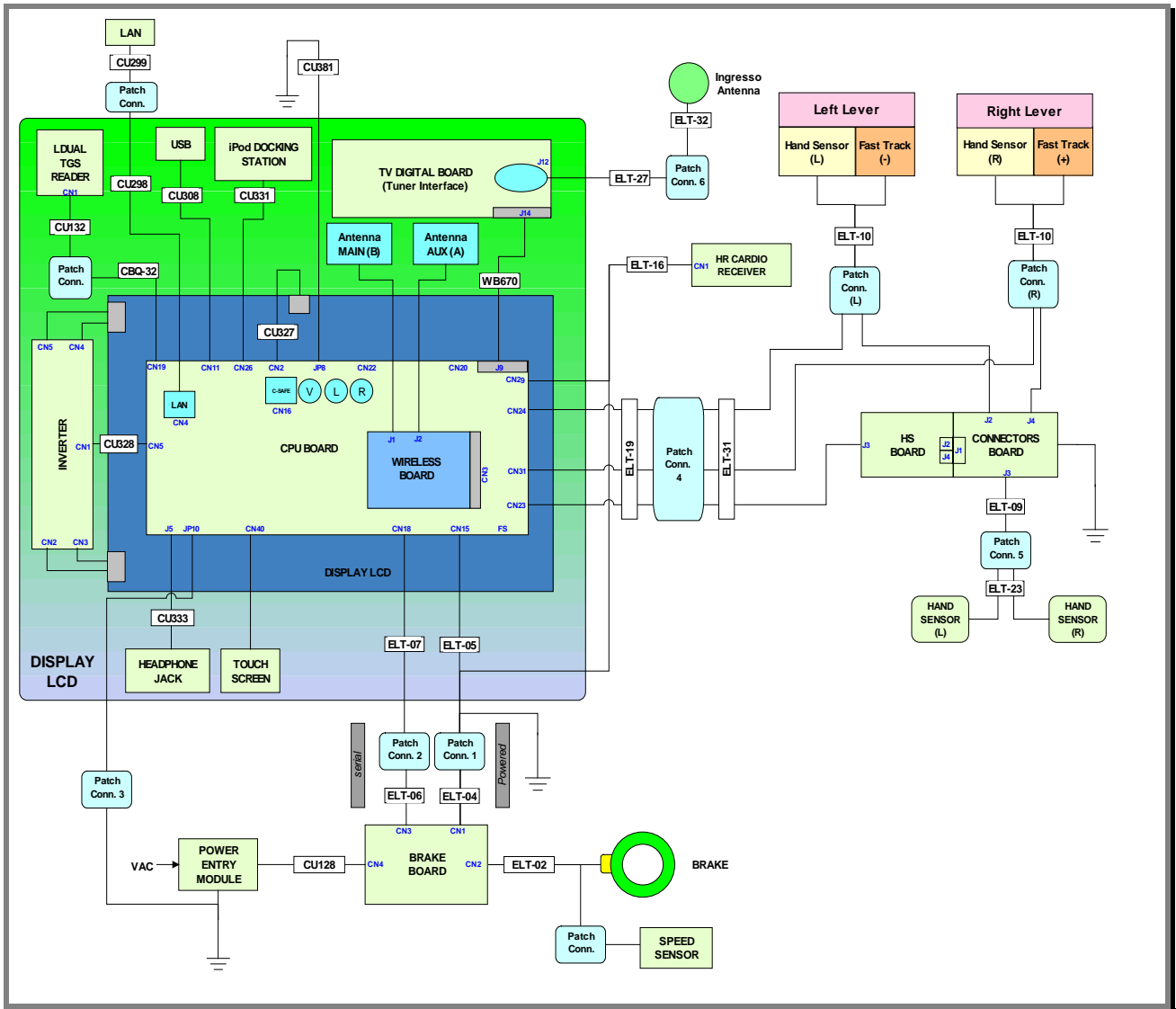
2.8.3. POWERED MODEL 700 (ARM BOARD)



2.8.4. SELF-POWERED MODEL 700SP (ARM BOARD)



2.8.5. POWERED MODEL 700VISIO (CPU BOARD)



2.9. CABLES



The colour of the cables can be changed, refer in particular to the Pin Out.

2.9.1. CBQ CABLES

<i>CBQ-13: C-Safe Board cable (LED Only)</i> <i>(Display Board- C-Safe Board)</i>			
Display Board CN8	Signal	Colour	C-Safe Board CN1
<i>1</i>	<i>Digital #1</i>	<i>Flat cable</i>	<i>1</i>
<i>...</i>	<i>...</i>	<i>...</i>	<i>...</i>
<i>14</i>	<i>Digital #14</i>	<i>Flat cable</i>	<i>14</i>

<i>CBQ32: TGS cable</i> <i>(Patch Conn. – CPU / ARM Board)</i>				
ARM Board CN7	CPU Board CN19	Signal	Colour	Patch Conn.
<i>1</i>		<i>Power +12Vdc</i>	<i>Brown</i>	<i>3</i>
<i>2</i>		<i>RX</i>	<i>Blue</i>	<i>5</i>
<i>6</i>		<i>TX</i>	<i>Black</i>	<i>9</i>
<i>8</i>		<i>GND</i>	<i>Red</i>	<i>1</i>

2.9.2. CAVI CU

CU132: TGS signal cable (Patch Conn. – Dual TGS reader)			
Patch conn.	Signal	Colour	Dual TGS Reader CN1
3	+12Vdc power	Black	1
5	RX	Green	2
9	TX	Black	3
1	GND	Black	8

CU128: 100/220V power signal cable (Power entry module – Brake Board)			
Power entry module	Signal	Colour	Brake board CN4
N	NEUTRAL	Light Blue	1
F	PHASE	Brown	3
T	GROUND	Yellow/Green	5

2.9.3. CAVI ELT

ELT-01: : Generator cable (self-powered only) (Brake Board - Generator – Battery – Battery charge input)					
Brake Board: CN3	Signal	Colour	Generator	Battery	Battery charge input
10	+ GEN	Red	Faston		-
8	- GEN	Black	Faston		-
4	RPM Signal	White	Faston		
2	V+ tension from battery charge	Red	-		welded at the internal contact (+)
7	V- tension from battery charge	Black	-		welded at the internal contact (-)
1	V+ Battery	Red	-	Faston (+)	-
6	V- Battery	Black	-	Faston (-)	-

ELT-02: Brake power supply cable (Brake Board - Brake – Speed Sensor)				
Brake Board CN2	Signal	Colour	Brake	Speed Sensor
1	Brake power supply +	Brown	Fast on	-
2	Brake power supply -	Brown	Fast on	-
3	SPM	Red	-	Faston connected to brown cable
4	SPM Reference	Black	-	eyelet
5	n.c.	-	-	-
6	n. c.	-	-	-

ELT-04: High Kit and Low Kit power supply cable (Brake Board – Patch Conn. 1)			
Brake Board: CN1	Signal	Colour	Patch conn. 1
1	GND	Yellow/Green	Fast on/eyelet
2	GND -12V	White	2
3	GND -5V	Yellow	3
4	sensing GND + 5V	Pink	4
6	+ 12 Vdc	Brown	6
7	+ 5 Vdc	Green	7
8	sensing + 5V	Grey	8

**ELT-05: High Kit and Low Kit power supply cable
(Patch Conn. 1 CPU/ARM Board)**

Patch conn. 1	Signal	Colour	ARM Board: CN1 CPU Board: CN15
1	GND	Yellow/Green	Fast on/eyelet
2	GND -12V	White	2
3	GND -5V	Yellow	3
4	sensing GND + 5V	Pink	4
5	n.c.	-	5
6	+ 12 Vdc	Brown	6
7	+ 5 Vdc	Green	7
8	sensing + 5V	Grey	8

**ELT-06: High Kit and Low Kit Serial cable
(Brake Board - Patch Conn. 2)**

Brake Board: CN3	Signal	Colour	Patch Conn. 2
1	Digital Gnd	Orange-White	1
2	Digital Gnd	Orange	2
3	NC	Green- White	3
4	Download	Green	4
5	Reset	Blue- White	5
6	NC	Blue	6
7	485 Tx/Rx +	Brown- White	7
8	485 Tx/Rx -	Brown	8

**ELT-07: Cavo comunicazione seriale fra Kit Alto e Kit Basso
(Patch Conn. 2 - CPU/ARM Board)**

Patch Conn. 2	Signal	Colour	ARM Board: CN9 CPU Board: CN18
1	Digital Gnd	Orange-White	1
2	Digital Gnd	Orange	2
3	NC	Green- White	3
4	Download	Green	4
5	Reset	Blue- White	5
6	NC	Blue	6
7	485 Tx/Rx +	Brown- White	7
8	485 Tx/Rx -	Brown	8

ELT-09: Handlebar sensor cable
(Connector board - Patch connector 5)

Connector Board J3	Signal	Colour	Patch Conn. 5
1	Gnd	Shield	1
2	Sensor signal reference	White	2
3	Left sensor signal	Black	3
4	Gnd	Shield	4
5	Sensor signal reference	Green	5
6	Right sensor signal	Red	6

ELT-10: Lever cable
(Patch Conn. L/R – HS and Fast Track LEVERS)

Patch Conn. (R) and (L)	Signal	Colour	Right LEVER Left LEVER	
			HS	Fast Track
1	Sensor signal	White	Faston	-
2	Gnd	Shield	-	
3	Lever button signal	Green	-	2
4	Sensor signal reference	Brown	Faston	-
5	Reference	Brown	-	4
6	+ 5Vdc Power supply	White	-	1

ELT-16: HR Cardio Receiver cable
(CPU/ARM Board – HR Cardio Receiver)

CPU Board: CN29 ARM Board: CN3	Signal	Colour	HR Cardio Receiver: CN1
1	+5 Vdc power supply	White	2
7	Pulse (beat to beat)	Black	4
8	Gnd	Green	1

ELT-19: Hand Sensor Board cable and Fast Track
(CPU/ARM Board – Patch Conn. 4)

Display Board			Signal	Colour	Patch Conn. 4
CPU:CN23 ARM: CN4	CPU:CN24 ARM: CN5	CPU:CN31 ARM: CN6			
1	-	-	+ 5Vdc Power supply	Brown	7
5	-	-	Out pulse	Green	2
6	-	-	Reference	White	1
-	1	-	+ 5Vdc Power supply	White	10
-	2	-	Left lever button (-)	Green	9
-	4	-	Reference	Brown	8
-	-	1	+ 5Vdc Power supply	White	5
-	-	2	Right lever button (+)	Green	4
-	-	4	Reference	Brown	3

ELT-23: Handlebar sensors cable (Patch Conn. 5 – Hand Sensor HANDLE)				
Patch Conn. 5	Signal	Colour	Hand Sensor HANDLE	
			Right (R)	Left (L)
1	Gnd	Shield	-	
2	Sensor signal reference	Black		down
3	Left sensor signal	White		up
4	Gnd	Shield	-	
5	Sensor signal reference	Black	down	
6	Right sensor signal	White	up	

ELT-31: Hand Sensor Board cable – Fast Track (Patch Conn. 4 - HS Board– CN (L) – CN (R) – Connector Board)							
Patch Conn. 4	Signal	Colour	HS Board: J3	Levers Patch Conn.		Connectors Board	
				CN (R)	CN (L)	J2	J4
1	Reference	White	1	-	-	-	-
2	Out pulse	Green	3	-	-	-	-
7	+ 5Vdc Power supply	Brown	2	-	-	-	-
3	Reference	Brown	-	5	-	-	-
4	Right lever button signal (+)	Green	-	3	-	-	-
5	+ 5Vdc Power supply	White	-	6	-	-	-
8	Reference	Brown	-	-	5	-	-
9	Left lever button signal (-)	Green	-	-	3	-	-
10	+ 5Vdc Power supply	Green	-	-	6	-	-
-	+ 5Vdc Power supply	Brown	-	4	-	-	2
-	Right sensor signal	White	-	1	-	-	3
-	Reference	Shield	-	2	-	-	1
-	+ 5Vdc Power supply	Brown	-	-	4	2	-
-	Left sensor signal	White	-	-	1	3	-
-	Reference	Shield	-	-	2	1	-

CU327: LVDS (Hitachi – ChiMei) cable (VISIO Only)
(CPU Board – LCD)

CPU Board: CN2	Signal	Colour	LCD
1	Vcc LCD	Orange	5
2	Vcc LCD	Violet	11
3	GND	Brown	23
4	GND	Green	29
5	Ztxn0	Black	3
6	Ztxp0	Yellow	1
7	GND	Blue	30
8	Ztxn1	Black	9
9	Ztxp1	Red	7
10	GND	Black	24
11	Ztxn2	Black	15
12	Ztxp2	Grey	13
13	GND	Red	17
14	Ztxcn	Black	27
15	Ztxcp	White	25

CU328: Inverter LCD “Fronteck” cable (VISIO Only)
(CPU Board – LCD Inverter)

LCD Inverter CN1	Signal	Colour	CPU Board CN5
11	+12Vdc Power supply inlet.	Black	1
1	GND	Black	2 (*)
4	ON - OFF	Black	3
3	GND	Black	4
12	+12Vdc	Black	5 (*)
2	Save - lamp	Black	6
5	GND	Black	2 (*)
10	+12Vdc	Black	5 (*)

(*) =Apply two wires on the same contact.

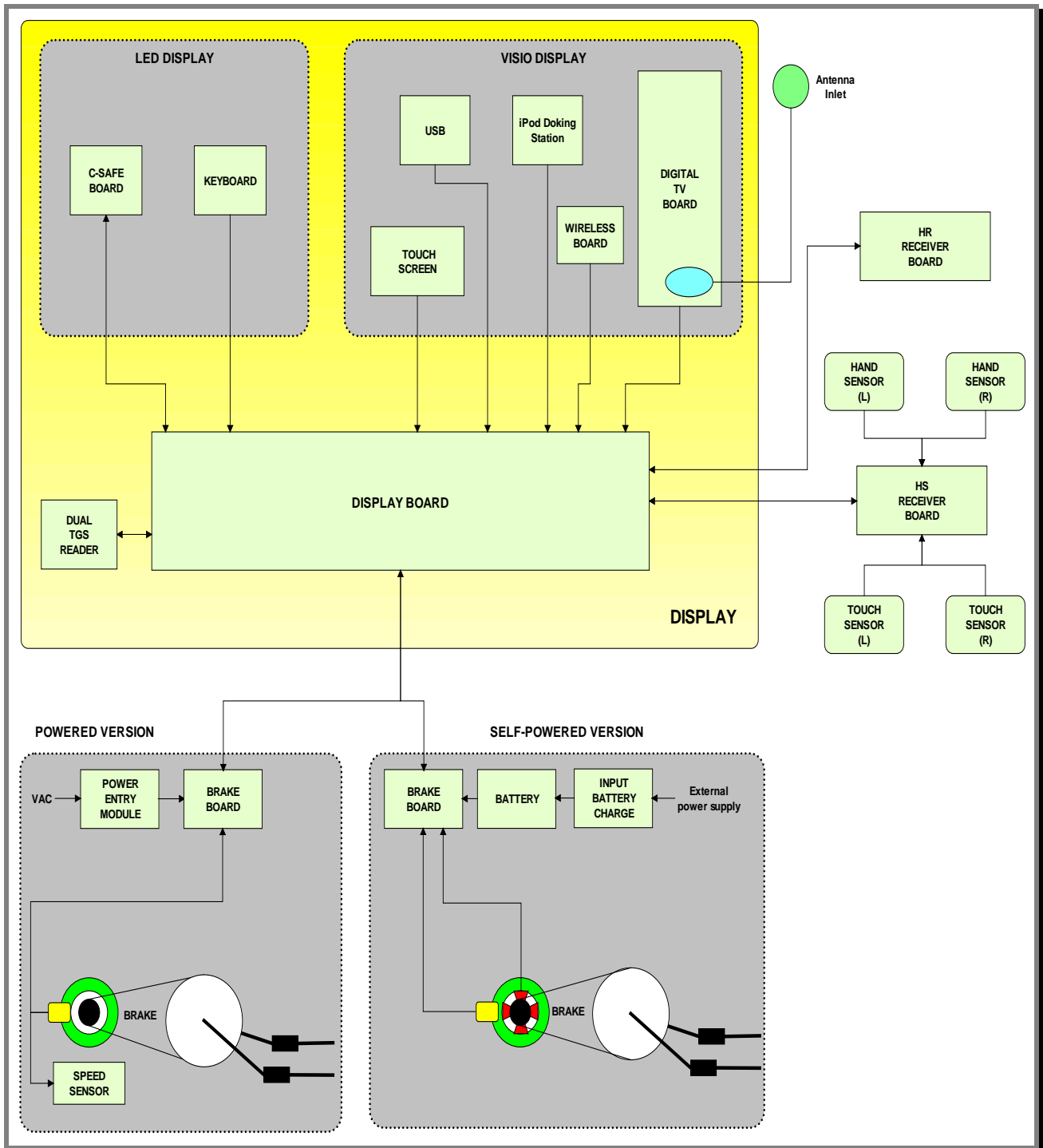
CU331: iPod signal cable (VISIO Only) (CPU Board – Docking Station)			
CPU Board: CN26	Signal	Colour	Docking Station
1	+V bus USB	Black	14
2	GND bus USB	Black	13
3	TX - RX	Black	11
4	RX – TX	Black	12
5	CTS	Black	10
6	+5Vdc	Black	9
7	GND	Black	8
8	GND	Black	7
9	Video Gnd	Black	6
10	Video siganl	Black	5
11	Gnd audio L	Black	4
12	L Signal audio	Black	3
13	R Signal audio	Black	2
14	Gnd audio R	Black	1

CU333: Audio headphone Jack cable (VISIO only) (CPU Board – headphone Jack)			
CPU Board J5	Signal	Colour	headphone Jack
2	Out_R	Green	4
4	Schield	Yellow	5
1	GND	Red	2
3	Out_L	Black	1

3. PRINCIPLES OF OPERATION

3.1. BLOCK DIAGRAM

The machine block diagram is illustrated in the figure below:



3.2. LED DISPLAY BOARDS

3.2.1. ARM BOARD: 500 AND 500SP MODELS

The display contains only one board which comprises the CPU, an ARM microprocessor, its logic circuits and a FLASH EPROM containing the operating program for the machine moreover, acts as the interconnection hub for all the components of the display and serves as the point of connection with the brake Board.

The main functions of the board are:

- Manages and process signals from:

- (1) *Keyboard;*
- (2) *HR receiver;*
- (3) *C-Safe Board;*

Optional:

- (4) *Dual TGS reader (if present).*

- distributes the voltages received from the Brake Board to the display;
- exchanges, via the RS-485 serial link to the Brake Board, the commands for controlling the brake;
- controls the LEDs and the 7-segment displays which provide feedback about the exercise session.

The board includes the following indicator LEDs:

LED	Colour	Description
LED1	GREEN	<i>if ON the +12 Vdc power supply from the Brake Board correctly reaches the board.</i>
LED2	YELLOW	<i>if ON the +5 Vdc power supply from the Brake Board correctly reaches the board.</i>

3.2.2. ARM BOARD: 700 AND 700SP MODELS

The Display contains only one board which comprises an ARM microprocessor, its logic circuits and a FLASH MEMORY containing the operating program for the machine moreover, acts as the interconnection hub for all the components of the display and serves as the point of connection with the Brake Board.

The main functions of the board are:

■ Manages and process signals from:

- (1) Keyboard;
- (2) HR Receiver;
- (3) HS Receiver;
- (4) Touch sensor;
- (5) C-Safe Board;

Optional:

- (6) Dual TGS reader.

- Distributes the voltages received from the Brake Board to the display;
- Exchanges, via the RS-485 serial link to the Brake Board, the commands for controlling the Electromagnetic Brake;
- Controls the LEDs and the 7-segment displays which provide feedback about the exercise session.

The board includes the following indicator LEDs:

LED name	Colour	Description
LED1	GREEN	if ON the +12Vdc power supply from the Brake Board correctly reaches the board.
LED2	YELLOW	if ON the +5Vdc power supply from the Brake Board correctly reaches the board.

3.2.3. C-SAFE BOARD

This board makes available a communication port, on 1 externally accessible connector, which can be used for interfacing compatible C-Safe devices such as the Cardio Theater readers.

This connector is situated on the back of the display.

These connectors can also be interfaced, using a special cable, to an external PC for programming the FLASH.

3.2.4. DUAL TGS READER

It's the device which allows the machine to interact with the Wellness System.

This board enables the machine to read the user's TGS key for performing workouts programmed with the proper SW of the Wellness System.

With Dual TGS reader it is possible to use both the Botom and the Mifare TGS keys.

3.3. VISIO DISPLAY BOARD

3.3.1. CPU BOARD: 700VISIO MODEL

The Circuit Board includes: a microprocessor, its control logic, a first FLASH MEMORY(containing the Operating System), a second FLASH, partitioned in two sections (HD1 and HD2) the first used for the training program of the machine, for storing video and other information/support material, the second partition for saving messages coming from the COMMUNICATOR and a third FLASH MEMORY(HD3) used for a back-up process.

It is the Circuit Board that connects all components of the display and acts as point of connection to the Brake Board.

The main functions of the board are:

■ **Manages and process signals from:**

- (1) LCD;
- (2) LCD Inverter;
- (3) Touch Screen;
- (4) Digital /Analogue TUNER Board;
- (5) LAN network board (integrated);
- (6) Wireless network Board;
- (7) HR Receiver;
- (8) HS Receiver;
- (9) Audio/Video external device Connectors Board;
- (10) Headphone Jack;
- (11) C-Safe (integrated);
- (12) Service USB port (integrated).

Optional:

- (13) Dual TGS Reader;
- (14) User USB port;
- (15) iPod docking station.

- Distributes the voltages received from the Brake Board to the Display;
- Exchanges, via the RS-485 serial link to the Brake Board, the commands for controlling the Electromagnetic Brake;

Sulla scheda è presente anche un LED di segnalazione:

LED name	Colour	Description
LED 1	GREEN	if ON, the +12Vdc power supply from the Brake Board correctly reaches the board.

3.3.1.1. Back-Up battery

The CPU board has a battery that act to maintain powered the internal clock when the machine is not connected to a power source.

3.3.2. LCD INVERTER

This device powers the LCD Display lamps. It receives DC power supplies (12Vdc supply and 3.3Vdc enable signal) from the CPU Board, and generates the AC voltage (380 Vac) needed to power the LCD.

3.3.3. DIGITAL/ANALOGUE TUNER BOARD

This is the board for receiving and managing the **Audio/Video** signal incoming from the antenna; it receives both digital and analogue signals.

It is directly connected to the antenna cable, whose signal is then amplified, split between a video and audio channel, encoded by the decoder and processed by a tuner that permits searching and tuning of both TV and radio channels.

The data is then sent to the CPU Board where it is processed and managed in order to correctly display it on the LCD Display.

LED name	Colour	Description
D4	RED	<p><i>ON if the power supply reaches the board.</i></p> <p><i>OFF if the power supply does not reach the board.</i></p> <p>FLASHING:</p> <ul style="list-style-type: none"> ▪ <i>if loading/starting the SW in the first seconds after it switch on;</i> ▪ <i>During the firmware upload;</i> ▪ <i>In case of HW/SW malfunctioning (and it continue to blink).</i>

3.3.4. INTEGRATED LAN NETWORK BOARD (WIRED)

The CPU board integrate a **LAN** network (*Local Area Network*) which can be used to connect the VISIO device in a local network. The connection should be realised through a UTP cable, with RJ45 connectors cat.5e/6.

VISIO device is compatible with LAN networks, which have a max. transmission speed between 10 and 100 Mbps.



The integrated network is obligatory in case of use for receiving IPTV stream.

3.3.5. WIRELESS NETWORK BOARD (WITHOUT CABLES)

This is a board connected directly to the **CPU Board**, which enables the VISIO device to connect to a **WLAN** (wireless local area network) as an alternative to a wired network.

The VISIO device has been constructed to be compatible with **Wi-Fi** technology (and in particular with the **IEEE 802.11b/g** standard), which offers a theoretical bandwidth capacity of up to 54Mbps over distances dependent on the characteristics of the setting where it is installed.

The typical indoor range is 30 m (open space):

- *Standard: IEEE 802. 11b/g*
- *Frequency band: 2.4GHz*
- *Security protocol: WPA/WPA2 or also less recent ones (e.g. WEP).*

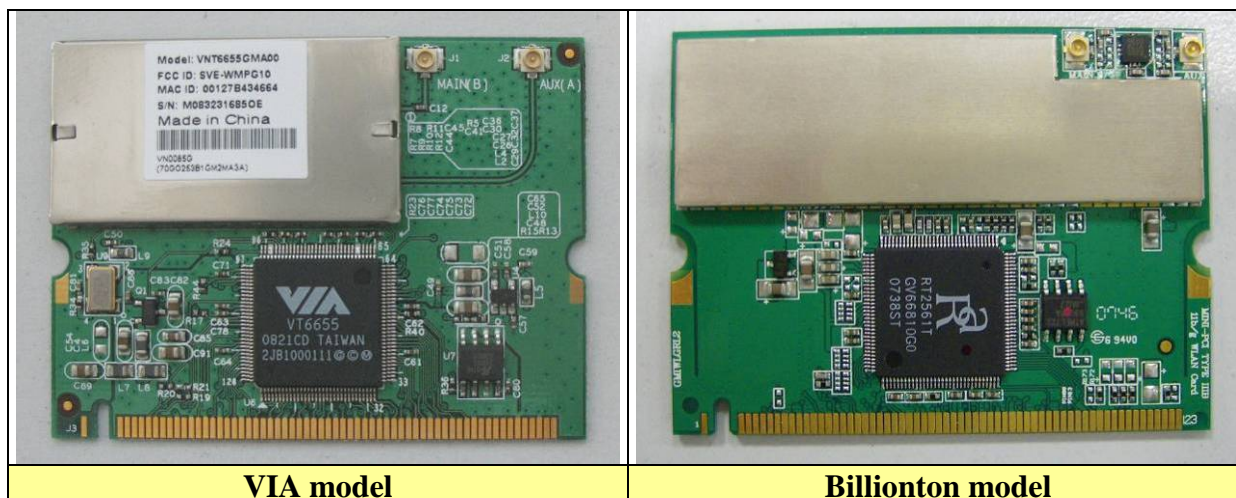


The WLAN connection may not guarantee the same performance as a wired network. The advantage of Wi-Fi is the absence of cables, but this is also a limitation in terms of protection against interference/disturbance, performance (*the stability of service and bandwidth may be intermittent*) and security (*vulnerability to attacks by hackers*). Where possible, it is in any case preferable to use the wired network. The possibility of using Wi-Fi also depends greatly on the type of service/application that is to be used in VISIO.

In particular:

- **Technogym Communicator: usable with suitable Wi-Fi network**
- **IPTV: NOT usable with Wi-Fi network; for this application, use of a wired network is essential.**

There are 2 different models of Wi-Fi network board used by Technogym, one produced by **VIA** and the other by **Billionton**. The 2 boards, as you can see in the picture below, are physically different and can be identified one from the other.



Whenever you replace the board with another that is not the same model, you always have to carry out the “*System recovery*” procedure using the Recovery USB stick.

3.3.6. AUDIO/VIDEO EXTERNAL DEVICE CONNECTOR BOARD

The board is positioned on the rear of the display of the equipment and makes available some connectors for connecting Audio / Video source and the external display on the base-band of LCD.

3.3.7. HEADPHONE JACK

The machine display has one jack for connecting headphones. The jack is connected on a stereo output of the CPU Board.

3.3.8. C-SAFE BOARD (INTEGRATED)

It 'a function that allows the connection using a appropriate cable for connecting other devices, such as: external PC suitably, programmed to control the machine (speed, level of difficulty, etc ...)

3.3.9. SERVICE USB PORT (INTEGRATED)

It is used to connect USB keys for updates: High Kit, Low Kit, TUNER Board, Dual TGS reader and the transfer of Radio and TV channels, from one VISIO device to another.

3.3.10. OPTIONAL ACCESSORIES

3.3.10.1. iPod docking station

It is the device that allows to plug & store iPod models, in a safe docking station and to control it from the ACTIVE Wellness TV interface.

With the docking station, developed for the full compatibility with iPod, it is possible to power, recharge and fully control it from the touch screen of the machine.

In the following table, all the compatible iPod (APPLE) models:

<p><i>iPod 5th gen.</i></p> 	<p><i>iPod Classic</i></p> 	<p><i>iPod mini</i></p> 
<p><i>iPod Nano</i></p> 	<p><i>iPod Touch</i></p> 	<p><i>iPhone</i></p> 

3.3.10.2. Client USB port

This is an additional port which can be installed on the VISIO Display, and makes available a USB port for connecting to external devices. The user can connect USB devices for playing a vast range of multimedia files, including: *mp3, wma, wav, wmv, MPEG2, MPEG4, DivX, XVID jpg.*

3.3.10.3. Dual TGS reader

It's the device which allows the machine to interact with the Wellness System.

This board enables the machine to read the user's TGS key for performing workouts programmed with the proper SW of the Wellness System.

With Dual TGS reader it is possible to use both the Botom and the Mifare TGS keys.

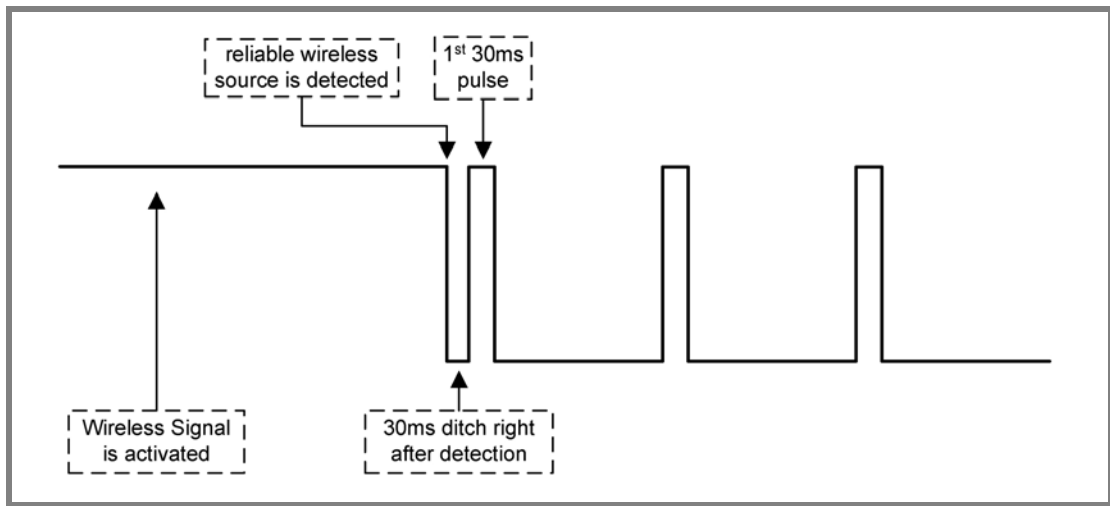
3.4. CARDIO RECEIVER BOARD

👉 The receiver reception area is approximately a circle with a 90cm radius. If there is electromagnetic noise produced by high voltage lines, radio transmitters, monitors, motors ecc... within this area, the receiver becomes saturated and no longer receives any signal.

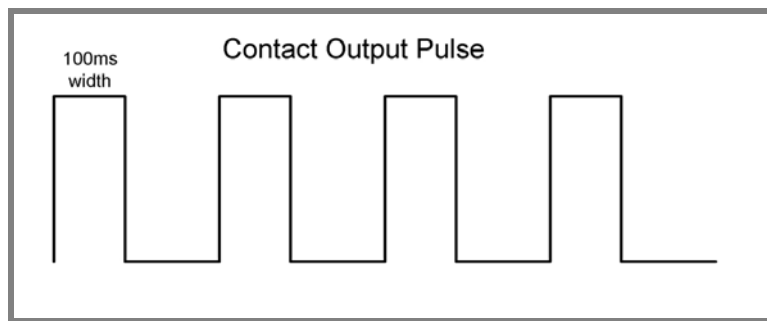
3.4.1. HS (HAND SENSOR)

This board manages the signals received from the Hand Sensors, used by the user when exercising. The Board receives the +5Vdc power supply, from the Display Board.

The Receiver Board, communicate with the Display Board in a **positive logic** mode. When the Board is in stand-by, the signal is +5Vdc; as soon the Board receives a reliable source of heart rate signal change to 0Vdc and then, for each heartbeat detected, generates a pulse going back to +5Vdc.



The Display Board, receives the signal generate from the Hand Sensor (*contact signal*) with a 100msec width signal.

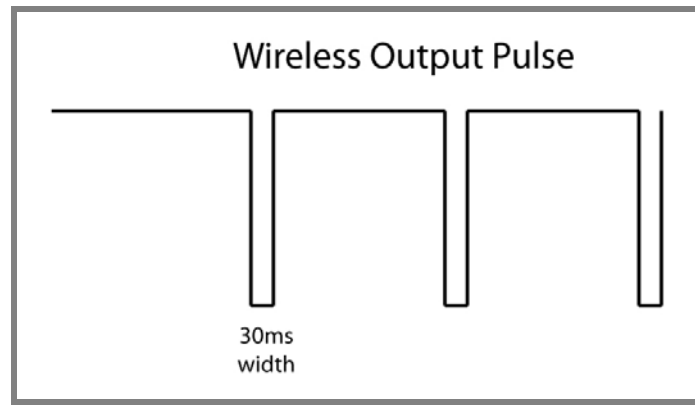


3.4.2. HR (CHEST BELT)

This board manages the signal received from the Telemetric Transmitter (*Chest Belt*), used by the user when exercising.

The Board receives the +5Vdc power supply, from the Display Board.

The Receiver Board, communicate with the Display Board in a ***negative logic*** mode. When the Board is in stand-by, the signal is +5Vdc and for each heartbeat detected, generates a pulse of +0Vdc, with a 30msec width signal.



3.5. BRAKE BOARD

At the moment there are 2 models of Brake board which have to be used on version: **powered** and **self-powered** (500SP/700SP), due to the fact they need different characteristics.

Each brake board consists of:

1. Power supply section which generates the low voltages used by the machine: +5Vdc (only for 700 and 700SP version) and +12Vdc (all version). Depending on the machine version, these voltages will be generated either from the 110VAC or 220VAC mains supply, or from the alternator-battery.
2. Section for RS-485 serial communications with the Display Board for:
 - *commands determining the resistance that is required of the Electromagnetic Brake;*
 - *Electromagnetic Brake error messages;*
 - *commands for modifying the circuit board configuration parameters;*
 - *commands for viewing the errors logged by the circuit board;*
 - *Commands of equipment usage (RPM, WATT, distance, etc...).*
3. Section which generates the current for the brake winding: varying the current produces a proportional variation in the resistance of the brake. The excitation current supplied to the brake is a function of the effort level selected on the display and the RPM value measured by the speed sensor (angular velocity of the brake disk) and is determined by the values stored in the braking table.

The board includes the following indicator 2 LEDs:

LED name	Colour	Description
LED1	GREEN	<i>if ON the board is supplying the brake winding. if BLINKING the Brake Board is in an error condition.</i>
LED2	YELLOW	<i>ON if the Brake Board is powered</i>

3.6. ELECTROMAGNETIC BRAKE

This is an eddy current brake, consisting of a flywheel weight and a flat copper disk that rotates in the air gap of a winding. Variations in the winding current produce changes in the magnetic field, which in turn varies the eddy currents induced within the copper disk and hence its resistance to "vertical" movement of the machine.

Two solenoids (*cylindrical-shaped coil composed of a series of very closely wound circular turns of a single strand of conducting material*) connected in series are supplied by an adjustable direct current generator to obtain a magnetic field of varying intensity. The inertia disk (flywheel) rotates between the coils.

As a result of its movement, each sector of the disk is crossed by a magnetic field flux that varies continuously, giving rise to electromotive forces within it that cause induced currents to circulate. These currents flow in a direction which opposes the cause that induced them, i.e. the movement of the disk inside the magnetic field. Consequently, they have a braking effect that slows down the movement of the disk. The braking effect is intensified as the magnetic field strength of the coils increases, and therefore with increasing speed of the disk. This operating principle also means that when the disk is stationary the braking action will be zero.

Unlike the majority of mechanical brakes, which operate by taking advantage of attrition forces, there electromagnetic brake has no parts subject to wear.

The winding resistance is approximately 5Ω Ohm, consequently the brake absorbs a maximum current of 2.2 A.

3.7. SPEED SENSOR

 **Only for models: POWERED.**

This consists of a magnetic induction sensor which detects the heads of the Electromagnetic brake disk fixing screws.

On the self-powered equipment, the speed as detected by a integrated sensor on the generator, (see at the paragraph: 3.9. "Alternator").

3.8. POWER ENTRY MODULE

 **Only for models: POWERED.**

This is a module consisting of:

- *power inlet socket;*
- *power outlet socket;*
- *fuse-holder for protecting line voltage and neutral with two 3.15A fast-blow fuses.*

It is situated on the side of the rear footboard.



WARNING: The maximum current extractable from the output of power entry module is 7A. This places an upper limit on the number of machines that can be connected together: do not connect more than N°8 equipments with a 220Vac mains supply and N°5 equipments with a 110Vac mains supply. If other types of machines are connected together, the maximum number is determined by their current draw.

3.9. ALTERNATOR

 **Only for models: SELF-POWERED.**

The alternator consists of a stator winding whose rotor is put into rotation by the movement of the pedals, generating the voltage necessary for the machine's operation.

Depending on the rate of pedalling and the resulting speed of rotation, it generates an alternating voltage which ranges from approximately 15-17 VAC at about 30-35 RPM to over 200 VAC for higher pedalling speeds.

Furthermore, analyzing the frequency of the AC voltage generated, it is possible to deduce the speed of rotor's rotation and then to deduce the user speed.

3.10. BATTERY

 **Only for models: SELF-POWERED.**

This is a 12 V – 4.5 AH battery which, in the self-powered version, supplies the machine whenever the alternator is unable to produce a sufficient voltage for powering the machine, and for at least 30 seconds after the user has stopped pedalling to allow data to be saved in memory.

The battery can be recharged in 2 ways:

- *during the exercise, through the Brake Board;*
- *in the Stand-By condition, from an external power supply included with the machine, which is able to fully recharge the battery in 8 hours.*



Do not use the machine during recharging with the external power supply.

3.11. EXTERNAL POWER SUPPLY INPUT

 **Only for models: SELF-POWERED.**

This is a socket for plugging in the external power supply that comes with the machine, which can be used to recharge the battery. It is situated on the side of the front footboard.

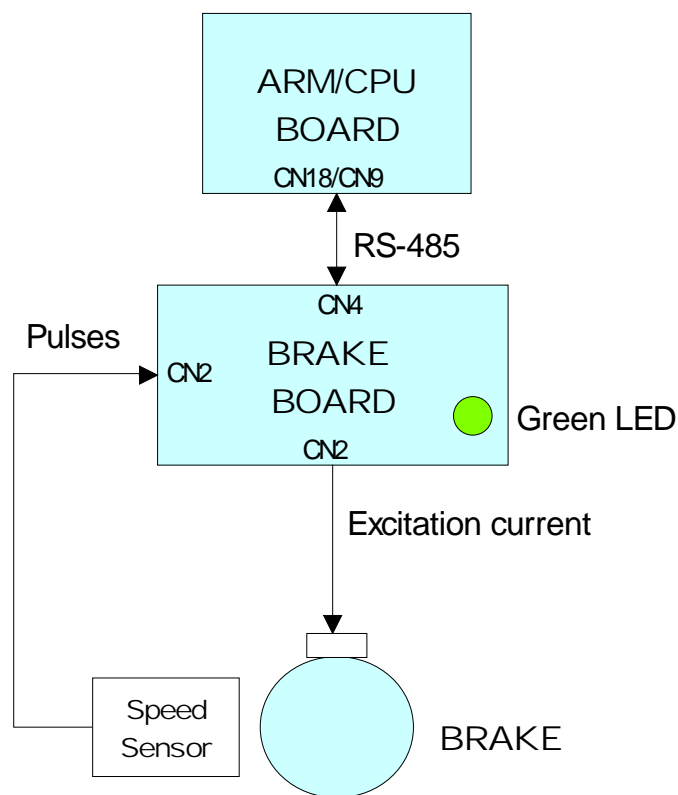
3.12. BRAKE CONTROL

3.12.1. MECHANICS

The motion of the pedals imparts a rotation to the primary shaft via the belts connected to the 2 pedals. The primary shaft is connected to the secondary shaft and so to the brake, by means of a belt. The speed sensor attached to the frame detects the heads of the screws which secure the disk to the flywheel, and generates a signal proportional to the speed.

3.12.2. CONTROLS

The control block diagram is as follows:



To obtain a given exercise effort level, the display board sends the required value of exercise speed in *rpm per minute* to the Brake board via the RS-485 serial link. Based on the commands received the brake board will then apply the appropriate excitation current to the brake winding, which generates an electromagnetic field.



When the brake interface board receives the signal to generate resistance, the green LED illuminates.

The electromagnetic field produced by the winding and the rotation of the disk will induce eddy currents in the disk itself, giving rise to a force that tends to brake its motion. This generates the exercise resistance.

The higher is the value of current generated from the Brake Board on the winding, the greater is the resistance produced. Furthermore, with the same excitement of the brake, the higher is the rotational speed of the disc, the greater is the resistance produced.



Due to the eddy currents, energy is dissipated on the brake disk in the form of heat.



The control on the **CURRENT** is of type **CLOSED LOOP**. The Brake Board calculates the current value to send on the winding of the brake, it controls the supply with a special driver circuit, and finally checks the actual presence on the brake circuit through reading and A/D conversion of current signal read.



Control over the **Resistance** actually present on the pedals (*effective user torque*) is **Open Loop**. The system (Brake Board) + (brake) provides no adjustment to calibrate the resistance value produced, but only using the braking table stored in the Brake Board. The accuracy of the braking system has a tolerance of $\pm 10\%$.

During the movement, the speed sensor detects the heads of the brake disk fixing screws, and produces a speed feedback signal that is sent to the Brake board. The brake board will adjust the excitation current of the brake winding so that the speed detected by the speed sensor is equal to the set value.



If the brake board does not receive a speed signal, which indicates that an exercise session is in progress, the machine will not produce any resistance.

During the movement, the brake board monitors for possible malfunctions. The errors which can occur are:

Error Code	Description
1	OVERHEATING: this condition occurs when the temperature detected by the sensor on the circuit board exceeds 90°C.
8	OVERVOLTAGE: this condition occurs when the +12Vdc voltage goes above 13.7Vdc (only on the 500, 700 and 700WTVmodels).

In all that cases, the Brake Board interrupts the supply of current to the brake, the green LED changes from being steadily on to blinking and sends an error message to the Display Board which displays the "THE EQUIPMENT IS BLOCKED CONTACT TECHNOGYM TECHNICAL SUPPORT (X)" where "X" represents the Error Code detected.

3.12.3. THE SIGNALS INVOLVED

The machine uses the following control signals:

- **RS-485 Signal**
This is a digital signal exchanged between the **Brake Board** and the Display Board. There is no provision for monitoring its state.
- **Excitation current**
This is the current generated by the **Brake Board** (*pins 1-2 of connector CN2*) which supplies the brake winding. The current supplied is a function of the adjustment algorithm.
- **Pulses**
This is the signal produced by the speed sensor, and has the waveform shown in the figure below:

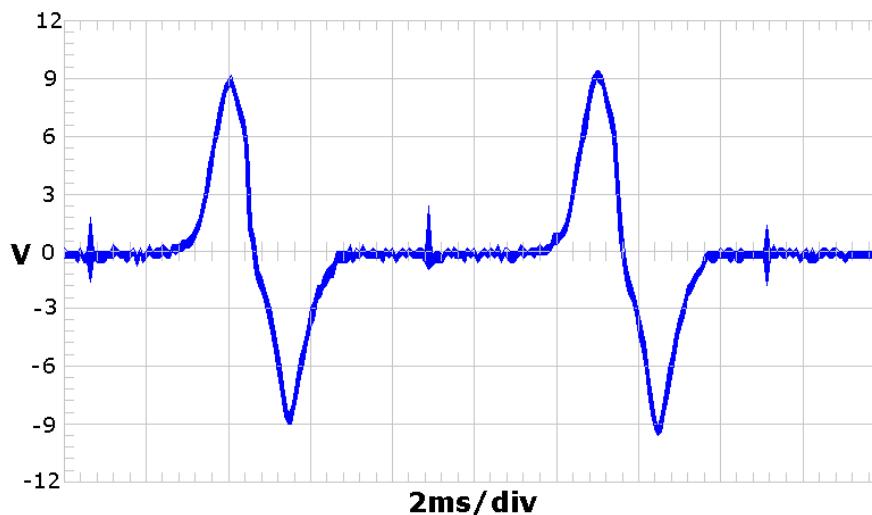


Figure 3.12-1

The signal enters the **Brake Board** (*pins 3-4 on connector CN2*), where it is used to determine the speed value (*RPM*) that is sent to the Display Board via the RS-485 serial link.



This signal can also be measured qualitatively using a multimeter. The voltage measured across the sensor terminals should be 0Vdc when the machine is stopped, and should increase to a few hundred mV during pedal movement: the higher the speed, the higher the measured voltage.



Since on the SP models the speed is calculated on the VAC generated by the alternator, it's not possible to measure or monitoring this signal using a multi meter.

Page intentionally left blank.

4. ACCESSORIES

4.1. CARDIO THEATER CONNECTION



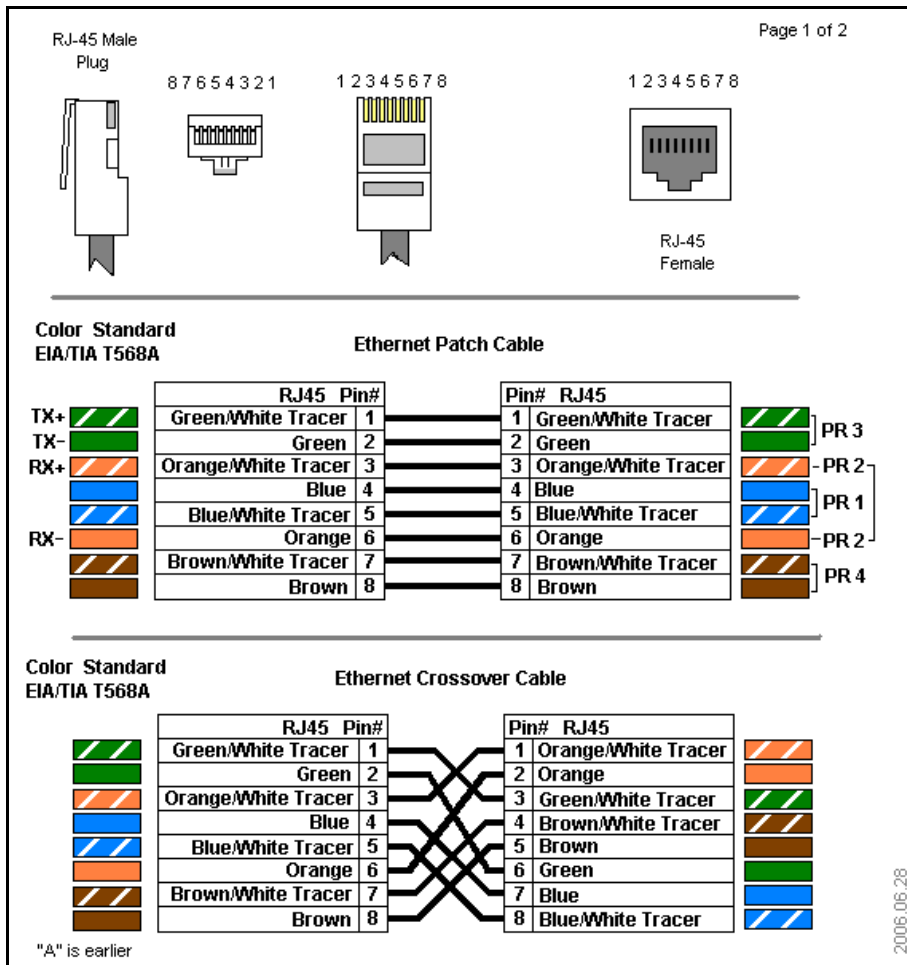
Only for LED version

The machine can be connected to the Cardio Theater by means of the **RJ45** connector on the C-Safe board. The Cardio Theater unit must be provided with a power cable having the following pin-out:

RJ45 Connector	Signal
5	+5Vdc
7	Ground



WARNING: for the numbering of the pins, on RJ45 connector, please refer to the diagram below:



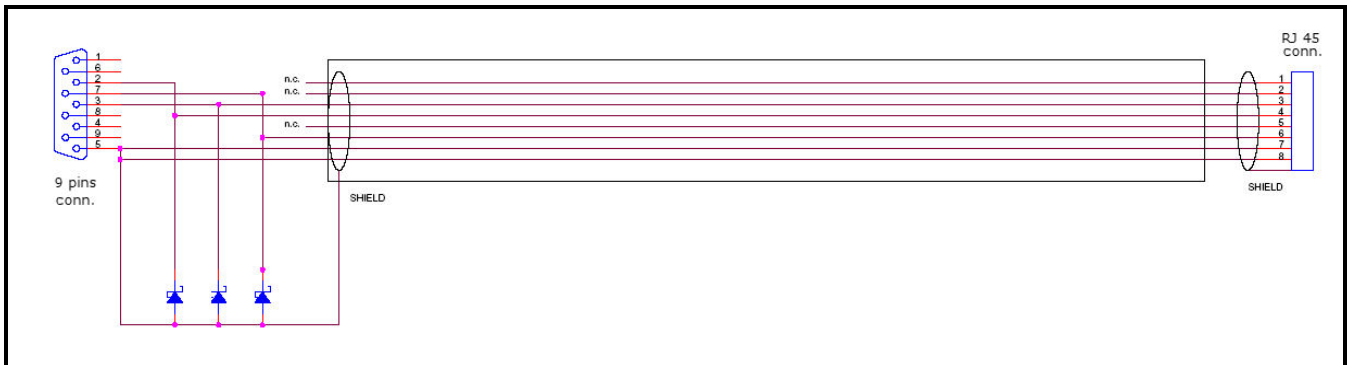
4.2. PC LINK FOR PROGRAMMING



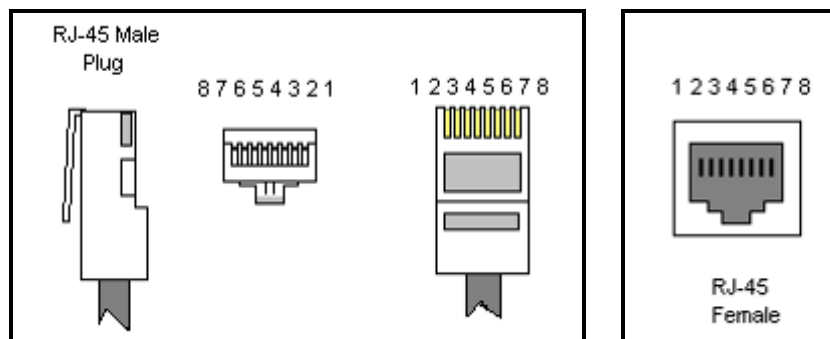
Only for LED version

The machine can be connected to a PC for programming by means of the RJ45 connector on the C-Safe board.

The cable to use must be wired as follows:

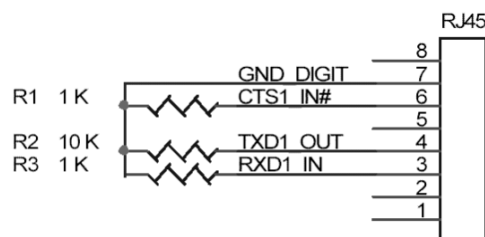


WARNING: for the numbering of the pins, on RJ45 connector, please refer to the diagram below:



When programming the machine sometimes it is necessary to fit plug into the free RJ-45 port on the back of the display, to avoid any type of interference during the operation.

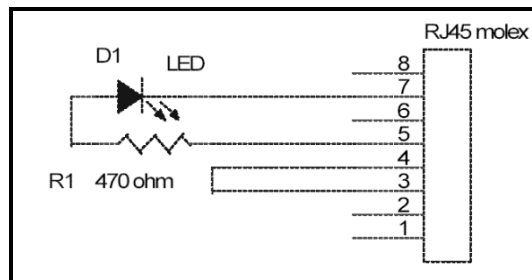
The wiring diagram of the RJ-45 plug is as follows:



Programming cable and plug can be ordered using the code **R0002534AC**.

4.3. MONITOR PLUG FOR C-SAFE PORT

When the plug code **0WC00639AA** is fitted into any one of the C-Safe ports on the machine, the corresponding LED should illuminate to indicate the presence of the 5Vdc supply on the port. During the C-Safe port test function, the plug connects the transmit channel directly to the receive channel, thereby producing a positive test outcome if the port is functioning correctly.



4.4. VISIOWEB UPGRADE

4.4.1. VISIO vs VISIOWEB

The 2 product versions differ mainly for 2 reasons, one it's about its functionality while the second it's about a technical characteristic.. They are briefly detailed below:

1. *On machines with **VISIOWEB** display it is possible for the user browsing and use internet services during the training session;*
2. ***VISIOWEB** has been developed on Linux instead of Windows CE used for **VISIO**. This difference can not be noticed by the final user because on both the product versions there is the same user interface and just few steps of the net configuration are different.*

4.4.2. VISIOWEB UPGRADE FOR VISIO MODELS

It is possible to upgrade an equipment from VISIO to VISIOWEB through a specific SW upgrade procedure, using the proper USB recovery stick and a correct configuration for internet service (if the infrastructure has been properly arranged).

The code to be used for this upgrade **ATS600**



CAUTION: this procedure must mandatory be done by a **TECHNOGYM** qualified engineer.

4.4.3. UPGRADE FROM LED TO VISIOWEB

There are upgrade kits available for converting Excite + machines from the version with traditional *LED Display* to the *VISIO Display*.

The kit includes all components needed to install the kit and installation instructions.

The table below gives the codes of the kits, to be chosen according to the TV standard used in the installation country.

VISIO UPGRADE KIT	CODE
Synchro DVB-T	A0000478-D
Synchro ATSC	A0000478-A
Synchro ISDB-T	A0000478-I

Table 4-1



CAUTION: At the end of the Upgrade steps of Standard Setting, as described in the relevant paragraph of the Service menu.

4.5. ACCESSORISE

ACCESSORISE	CODE
Dual TGS Reader15"	A0000481
iPod Docking Station 15"	A0000484
USB port 15"	A0000485

Table 4-2

5. INSTALLATION INSTRUCTIONS

5.1. SPECIFICATIONS AND REQUIREMENTS

For correct machine installation, make sure that:

1. The machine is installed on a level surface that is free of vibrations and has sufficient carrying capacity for the combined weight of the machine and user.
2. The place of installation is free of dust and sand.
3. The place of installation meets the operating temperature and humidity conditions specified in paragraph: 2.6. “Ambient specifications”.
4. The machine is not positioned close to sources of heat, sources of electromagnetic noise (television sets, electrical motors, antennas, high voltage lines, household appliances, etc...) or medical equipment.
5. To eliminate any interference with the cardio receiver, no transmitters should be placed less than 90cm from the display.

Only for powered models:

1. The mains voltage must match the value specified on the machine rating plate.
2. The electrical system must be correctly earthed.
3. The wall outlet used should be reserved for the machine and have a rating of at least 100VA.
4. The maximum number of machines connected in cascade should be that indicated in paragraph: 3.8. “Power entry module”.
5. Position the mains lead of the machine where it will not be underfoot.
6. For the installation of machines equipped with VISIO, refer to the relevant chapter of the manual specific.

5.2. MOVING THE EQUIPMENT

To move the equipment from the packing pallet to the floor, lift as shown in the picture and then slide it on the floor.



Given the weight of the equipment, we recommend 2 person be involved in lifting it.



AVVERTENZA: Lift the equipment by holding onto the frame and not the levers or the control pannel. Take great care when moving the equipment and positioning it on the ground, as it may overbalance.

1. The equipment has two fixed rear wheels. To move the equipment, lift it up slightly, as shown in the illustration, and push it forwards and backwards.

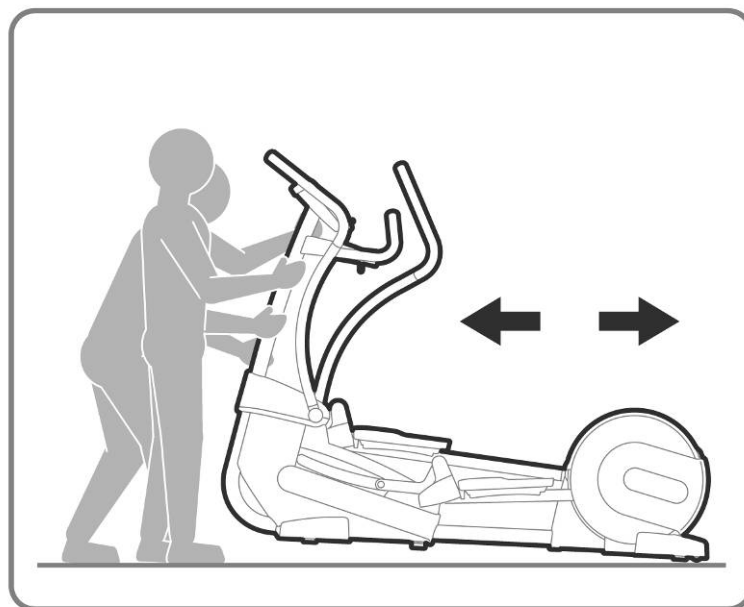


Figure 5.2-1



After every moving, check if the equipment is flat, adjusting the left foot, as indicated at the paragraph: 8.4. “The machine is not flat”.

2. If wheels cannot be used on the floor, move the equipment using standard lifting and transport devices.

5.3. RECOMMENDED ANTENNA SIGNAL REQUIREMENTS



All the information about the minimum requirements concerning the antenna signal are detailed in the proper manual “Electrical and antenna requirements” you can find and download into the Technogym Direct.

5.4. INSTALLATION

To correctly install the machine, proceed as follows:

1. Ensure that the specifications and requirements for installation have been met (see paragraph: 5.1. “Specifications and requirements”).
2. Position the machine as specified above, on a level surface that is free of vibrations and has sufficient carrying capacity for the combined weight of the machine and user.
3. Depending on the destination country, the machine may be shipped partially disassembled, packed inside a special carton and fixed to a pallet, or fully assembled, wrapped in clear plastic and fixed to a wooden pallet.

Follow the assembly operations described in the instruction sheets supplied with the machines.

Only for POWERED models:

4. Connect the mains lead to the power inlet socket on the machine.
5. Place the on/off switch in the 0 position.
6. Plug the mains lead into the wall outlet.

Only for VISIO models:

7. Connect the antenna cable to the wall outlet and make sure all the technical requirements are respected according to the specific paragraph of this manual.

5.5. FIRST POWER-ON

After completing the installation procedure, the machine is ready for use.

On the **POWERED** models, simply turn the on/off switch from position 0 to position 1, while on the **SELF-POWERED** models (*identified with the initials SP*) it is necessary to get on the machine and start pedalling.


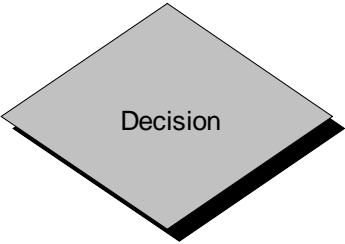

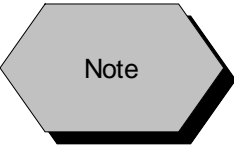


On power-up the machine performs a *Check-Up* of the High Kit and Low Kit assemblies. After completing the *Check-Up*, the machine enters the *Stand-By* state, awaiting a command from the keyboard.

To check the correct operation of the machine:

- *Get on the machine;*
- *Check that the displayed speed varies accordingly;*
- *Check that exercise resistance varies when the “+” and “-“ effort level keys are pressed, or the touch sensors, and the effort level change from 1 to 25;*
- *Put on the heart rate meter and check that the machine correctly reads the heart rate value;*
- *Grasp the sensors and check that the machine correctly reads the heart rate value;*
- *Only for VISIO models, Carry out the “Touch Screen Calibration” procedure described in the relevant paragraph of the Service menu.*

6. TROUBLESHOOTING

The troubleshooting procedures are illustrated by means of flow diagrams. To facilitate interpretation of these diagrams, the following standard box shapes are used:

	<p>This type of box is the START point of the troubleshooting procedure. It typically contains a description of the problem or malfunction.</p>
	<p>This type of box represents a decision point in the troubleshooting procedure. It typically contains a description of the CHECK to be made, with an outcome that is either a positive (YES) or negative (NO) response.</p>
	<p>This type of box is a step in the troubleshooting procedure where an ACTION must be carried out. It typically contains a description of the ACTION necessary to resolve the problem. Therefore, after executing the specified ACTION:</p> <ol style="list-style-type: none"> 1. <i>Check whether the problem has been resolved;</i> 2. <i>If the problem persists, it is recommended to resume the troubleshooting procedure from the point before the action was carried out.</i>
	<p>Clarification of the operation in progress or that will be below</p>
	<p>A <u><i>circled number</i></u> (such as that shown on the left) next to a box of the troubleshooting procedure indicates that more detailed instructions for performing that particular check or action are provided below the flowchart.</p>
	<p>A <u><i>circled letter</i></u> (such as that shown on the left) is used to mark a point in the procedure. Typically, this indicator is used in page changes.</p>

 The connectors indicated in the following pages, refer to 700 powered models Boards, unless otherwise indicated.

6.1. TROUBLESHOOTING MENU: LED MODELS

The configuration procedure is invoked when the machine is in Stand-By mode, using a different procedure for the 500 and 700 models.

6.1.1. ACCESSING CONFIGURATION OF 500 MODELS

Simultaneously press the **ENTER**, **↑**, **CLEAR** keys. The following prompt appears on the display:

ENTER PASSWORD:

To access the procedure, type in the password **2501** which protects against unauthorized access and press **ENTER** to confirm. To enter the password, increase or decrease the displayed value using the **↑** and **↓** keys, or use the **+/- GOAL** keys to scroll through and modify the individual digits.

At this point there are two options available:

↑ = Tech Config
↓ = Troubleshooting

Press numeric key **↓** to access the *menu for configuring technical parameters*; the machine display will begin showing the current configuration, structured as in the diagram below:

6.1.2. ACCESSING CONFIGURATION OF 700 MODELS

It is invoked, when the machine is in Stand-By mode.

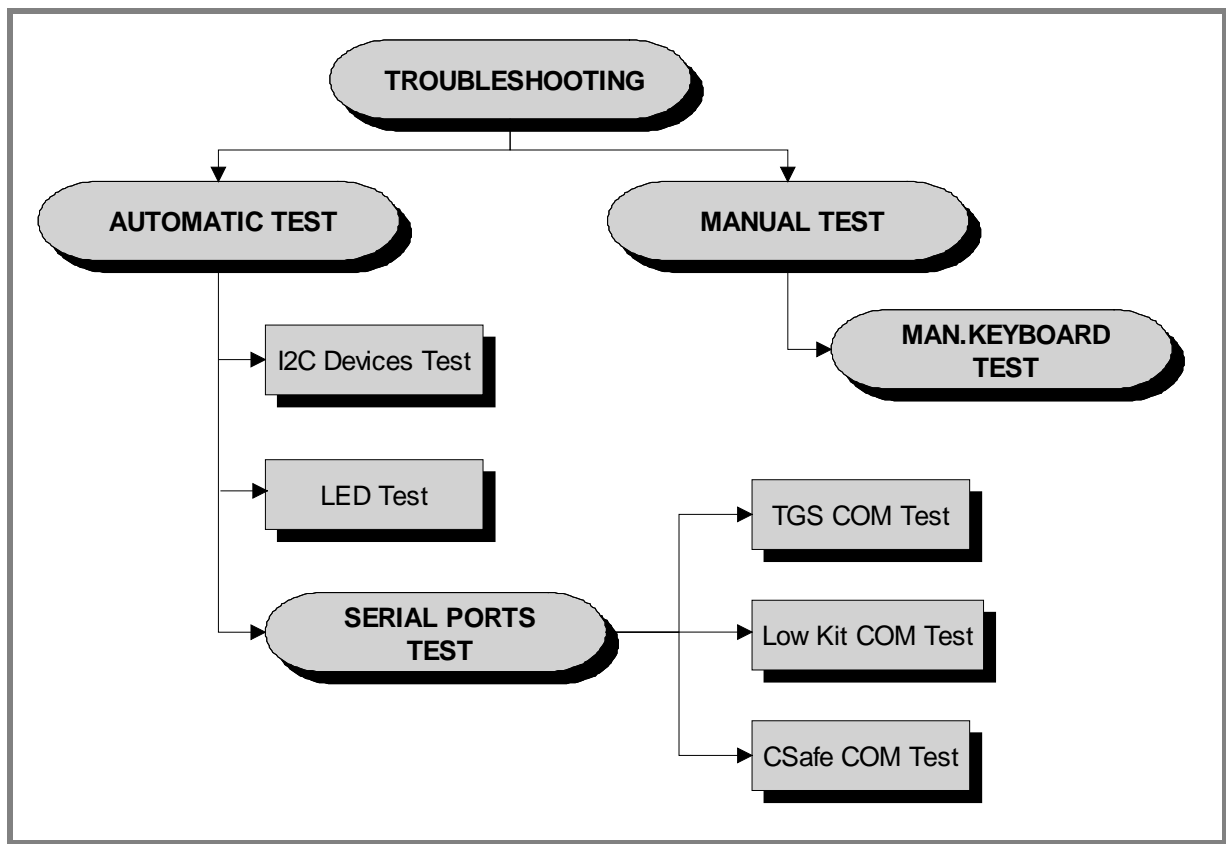
Simultaneously press the keys **369** for LED models. The following prompt appears on the display:


ENTER PASSWORD:

To access the procedure, type in the password **2501** which protects against unauthorized access and press the **ENTER** key to confirm. At this point there are two options available:

1 = Tech Config
2 = Troubleshooting

Press numeric key **2** to access the *menu for configuring technical parameters*; the machine display will begin showing the current configuration, structured as in the diagram below:



- 
To scroll through the list of available functions, press the + or – speed keys to display the next or the preceding item; confirm the choice by pressing ENTER. To cancel the operation, press the CLEAR key for a few seconds.

*The tests are divided into two groups: **Automatic** and **Manual**, and the prompt for a choice appears immediately on accessing the troubleshooting menu.*

6.1.3. AUTOMATIC TEST

The tests grouped under this section conduct checks on the machine's operation in a fully automatic manner. After selecting the desired test using the + and – effort level keys, press **ENTER** to initiate the test and then await the result. Press **ENTER** again to continue, and use the **CLEAR** key to return to the higher menu level, holding it down for a few seconds. The various tests are described below.

6.1.3.1. I2C Devices Test

The I2C Devices test checks the communication following the 32K and 256K. The test can have outcomes:

- **“Test Successful, press Enter to continue”**: Signifies that the transmission and reception of data packets between the I2C devices and the display board was completed successfully.
- **“EEPROM Error, press Enter to continue”**: Signifies that the display board is having problems communicating with its memories.

6.1.3.2. LED Test

The LED test checks the functioning of the display by lighting all the LEDs in the matrix. It also tests the buzzer by changing the frequency to produce a variation in the tone of the sound.

There is no message displayed concerning the outcome of this test, which must therefore be checked visually.

6.1.3.3. Serial Ports Test

The serial ports test checks the communications on the following interface ports:

- *C-Safe COM test;*
- *Low Kit COM test;*
- *TGS COM test.*

Using the + and – effort level keys, select the desired test item and confirm by pressing **ENTER**. The test can have two outcomes:

- *“Test Successful, press Enter to continue”:* This means that the test was completed successfully, i.e. that the communications on the selected serial port are functioning correctly.
- *“COMx error, press Enter to continue”:* This means that the outcome of the test was negative: the message will specify COM1 in the case of the C-Safe COM test, COM2 in the case of communications with the low kit, or COM3 in the case of the TGS COM test.



The “TGS COM test” done on machine not provided with the key reader gives a fail outcome. The same if the “C-Safe COM test” is done on a machine which C-Safe port is not plugged with the monitor plug described at paragraph: 4.3. Monitor plug for C-Safe port”.

6.1.4. MANUAL TEST

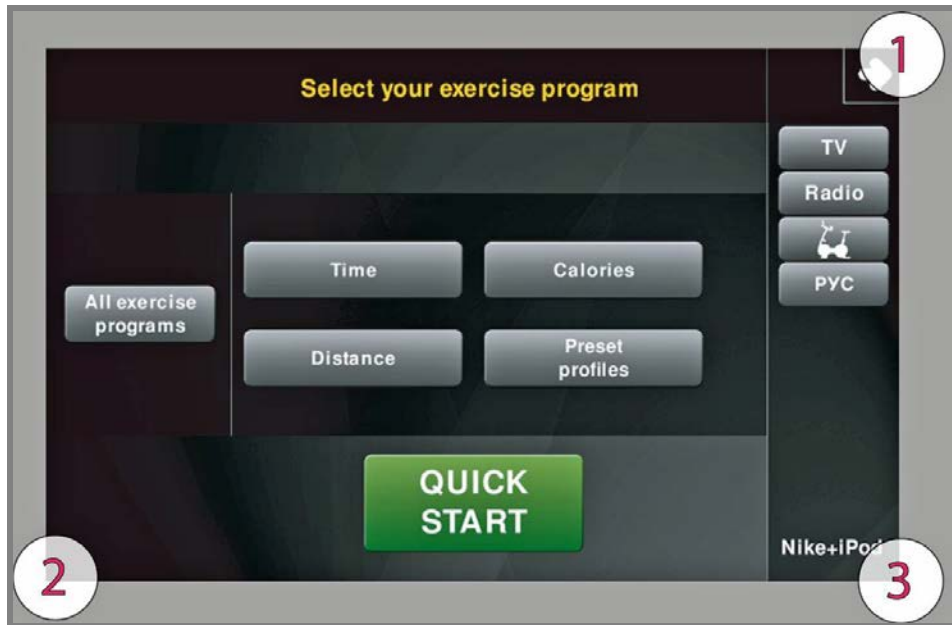
The tests grouped under this section conduct checks on the machine’s operation in a fully automatic manner. After selecting the desired test using the + and – effort level keys, press **ENTER** to initiate the test and then await the result. To exit test mode, press and hold down the **CLEAR** key for a few seconds.

6.1.4.1. Man. Keyboard Test

The manual keyboard test checks the functioning of all the keys on the keyboard. After accessing the test by pressing **ENTER**, the message “**Press all buttons (beep=OK)**” appears on the display. Pressing each key will produce an audible signal; if a key does not produce the beep it means it is not working properly.

6.2. TROUBLESHOOTING MENU: VISIO MODEL

The procedure is activated by pressing the top right-hand corner, the bottom left-hand corner and the bottom right-hand corner of the screen in that sequence when the equipment is in Stand-By, as shown in the figure below.



A new display will appear from which you can gain access to the various configuration menus, by entering the password on the number keyboard:

Enter the password **2501** and press the **ENTER** key to confirm or **EXIT** to quit.

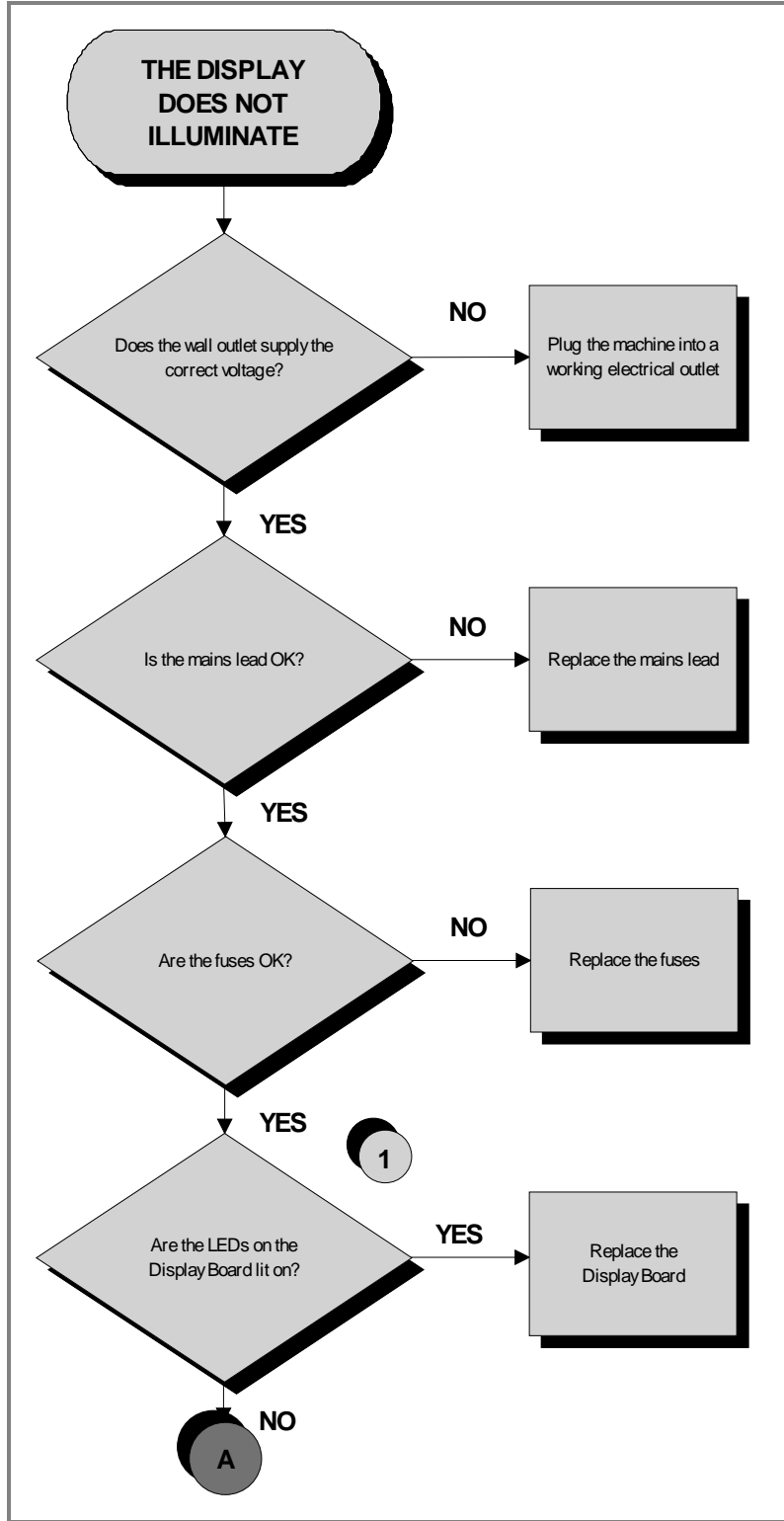
By selecting the key which is highlighted in red, you will gain access to the **TROUBLESHOOTING** menu:



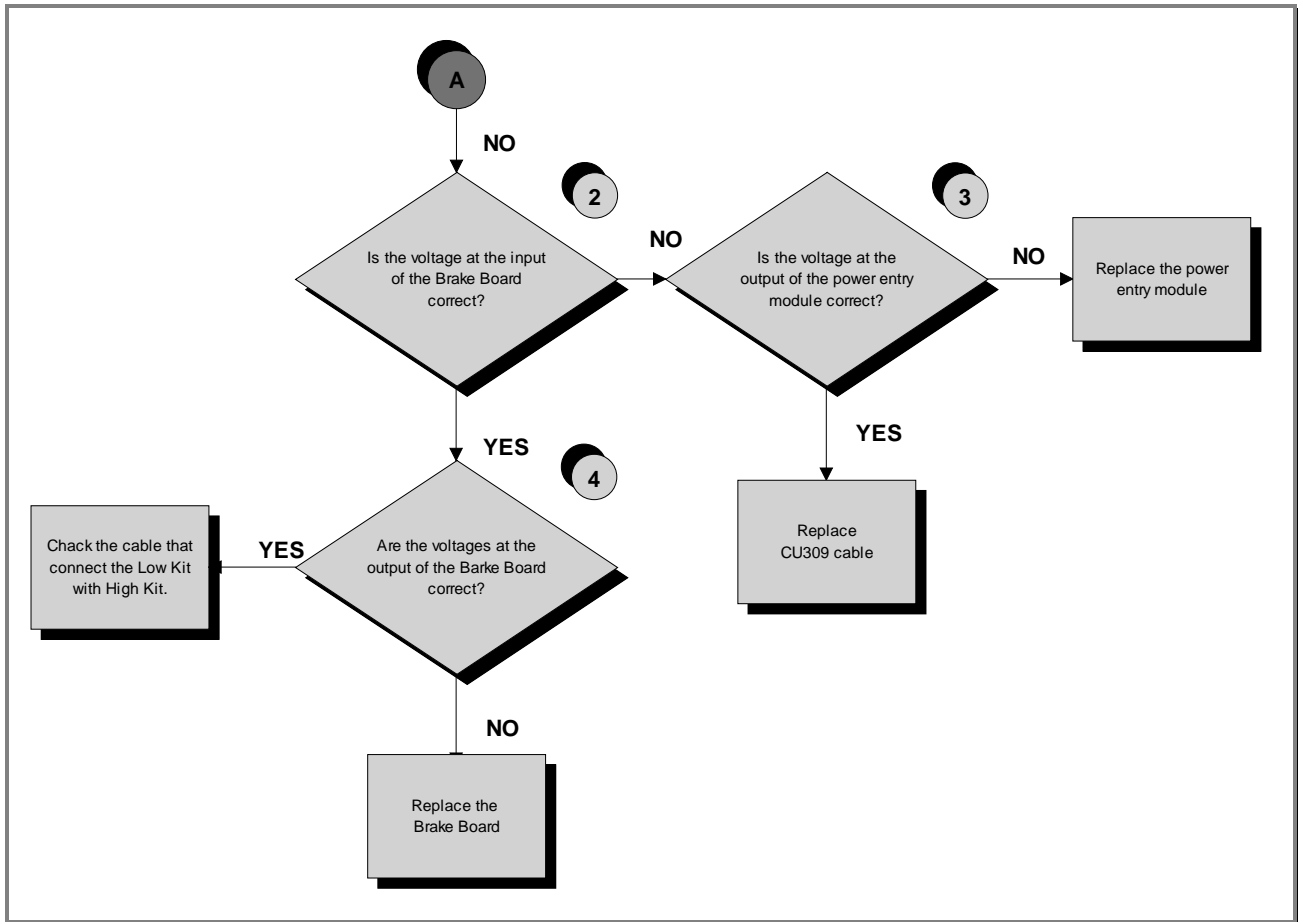
For the following menu, please refer to the relevant chapter in the **VISIO** manual.

6.3. THE DISPLAY FAILS TO ILLUMINATE

6.3.1. LED MODELS



Continued on following page ...



Follow the procedure step by step to correctly diagnose the problem. Take particular care with the checks highlighted by circled numbers, which are described in detail below:

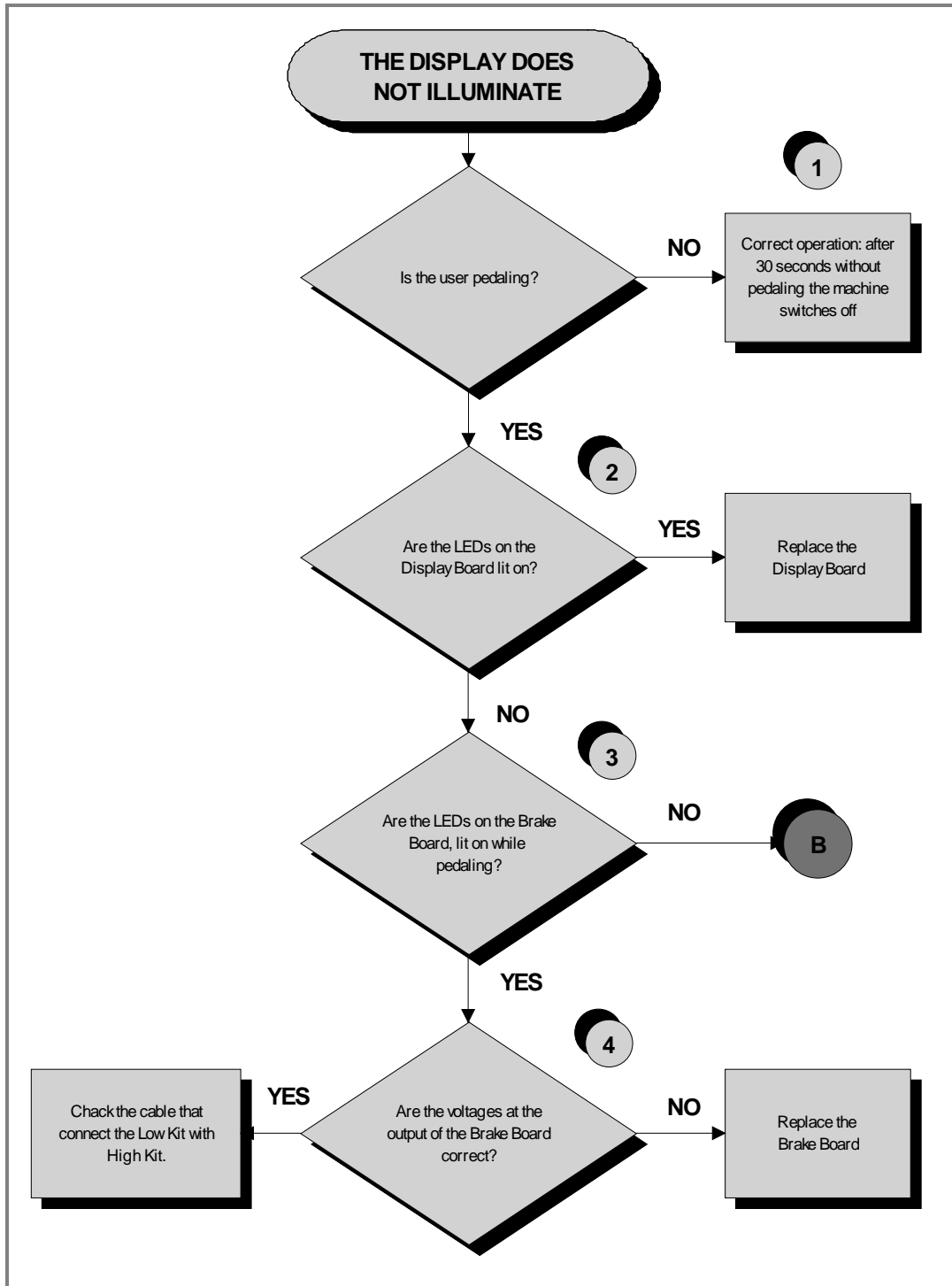
- (1) Check the **LEDs 1 and 2** (green and yellow), of Display Board, are correctly lit on.
- (2) Place the tester probes across pins **3 and 1** of **CN4** connectors on the Brake Board. The measured value should be approximately 220Vac or 110Vac depending on the mains voltage.
- (3) Slightly lift up the Faston on the machine power entry module. Place the tester probes across the live and neutral pins on the same connector. The measured value should be approximately 220Vac or 110Vac depending on the mains voltage.
- (4) Using a tester, check that all the output voltages on connector **CN1** of the Brake board. The measured value should be:
 - +12Vdc between pins **6-2**;
 - +5Vdc between pins **7-3**.



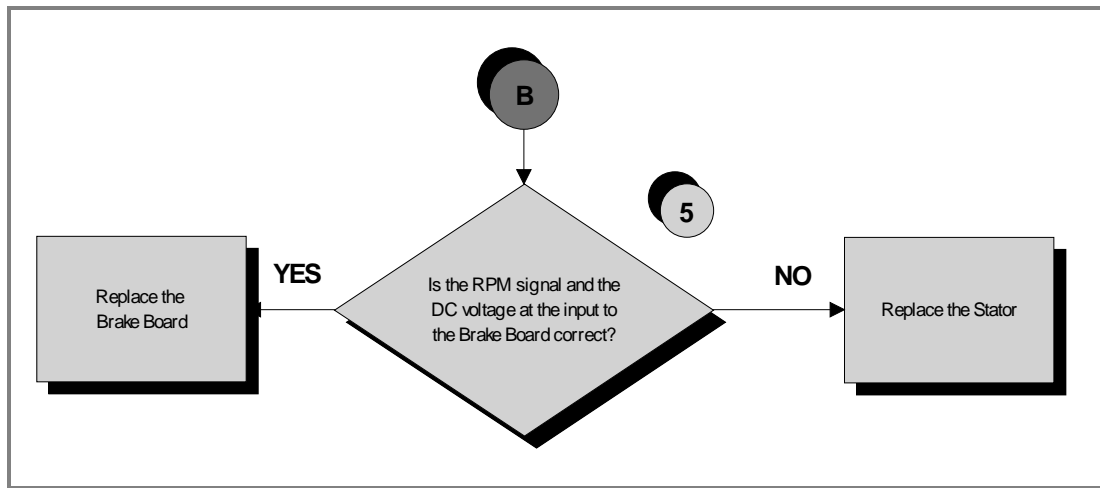
If you replace Display Board and/or Brake Board, check that its SW version is updated, otherwise install the latest version.

6.3.2. SP MODELS

6.3.2.1. The Display does not illuminate



Continued on following page ...



Follow the procedure step by step to correctly diagnose the problem. Take particular care with the checks highlighted by circled numbers, which are described in detail below:



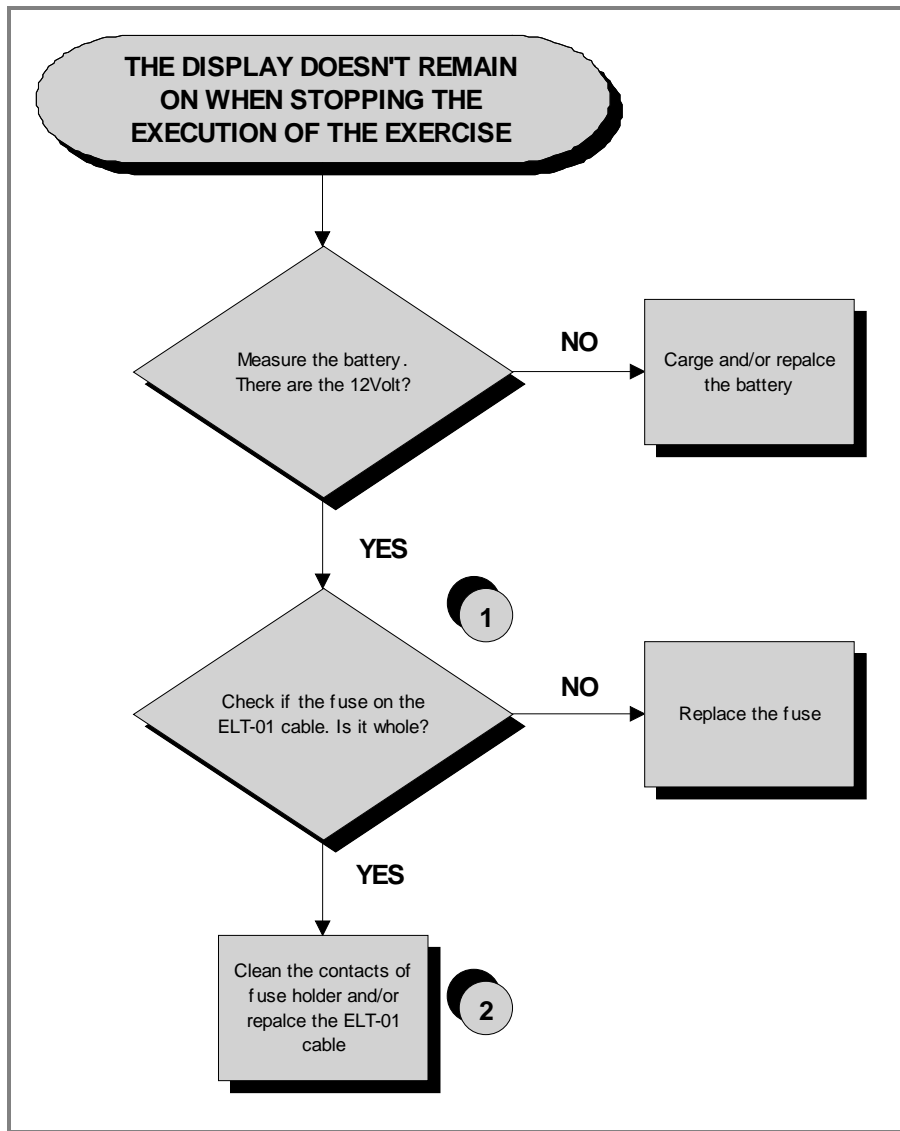
To speed up the troubleshooting procedure, check the state of the power indicator LEDs on the various circuit boards.

- (1) Check if the machine stays on for 30 seconds after having stopped pedalling. If the machine switches off in few seconds, check if the fuse on the **ELT-01**. cable is blown. Then check the battery charge, if it isn't about 12Vdc, recharge the battery for 8 hour with an external power.
- (2) Check the **LEDs 1 and 2 (green and yellow)**, of the Display Board, are correctly lit on.
- (3) Check if the **LEDs 1 and 2 (green and yellow)** of the Brake Board, are correctly lighting on, as described in paragraph: 3.5. "Brake Board".
- (4) Using a tester, check that all the output voltages on connector **CN1** of the Brake board. The measured value should be:
 - +12Vdc between pins **6-2**;
 - +5Vdc between pins **7-3**.
- (5) Using a tester, check the voltage on connector **CN3**, of the Brake board. The measured value should be 16-19Vdc, between pins **10** and **8**, nearly at 50RPM. Use a tester, to estimate the RPM signal on the **CN3** connector of the Brake board. The measured value should be approximately 30Vac between pin **4** and a ground point.



If you replace Display Board/Brake board, check that its SW version is updated, otherwise install the latest version.

6.3.2.2. The Display doesn't remain on when stopping the execution of the exercise



Continued on following page...

Follow the procedure step by step to correctly diagnose the problem. Take particular care with the checks highlighted by circled numbers, which are described in detail below:

- (1) Check if the fuse on the **ELT-01** cable is whole. If necessary replace the **F5A** fuse (A) indicated in the figure follows.
- (2) Clean the contacts of fuse holder inside of the fuse housing, highlight in the figure follows:

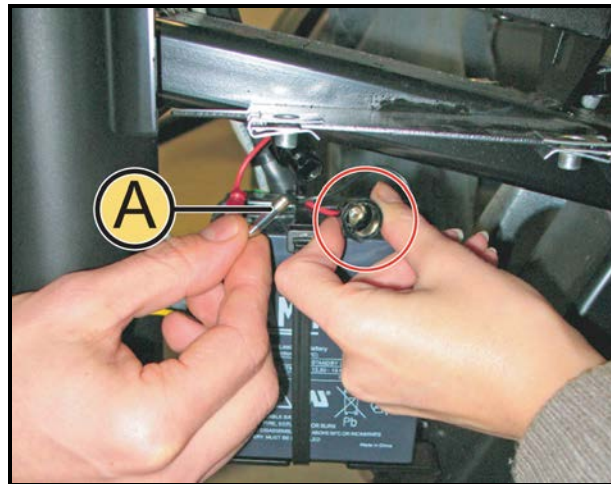


Figure 6.3-1

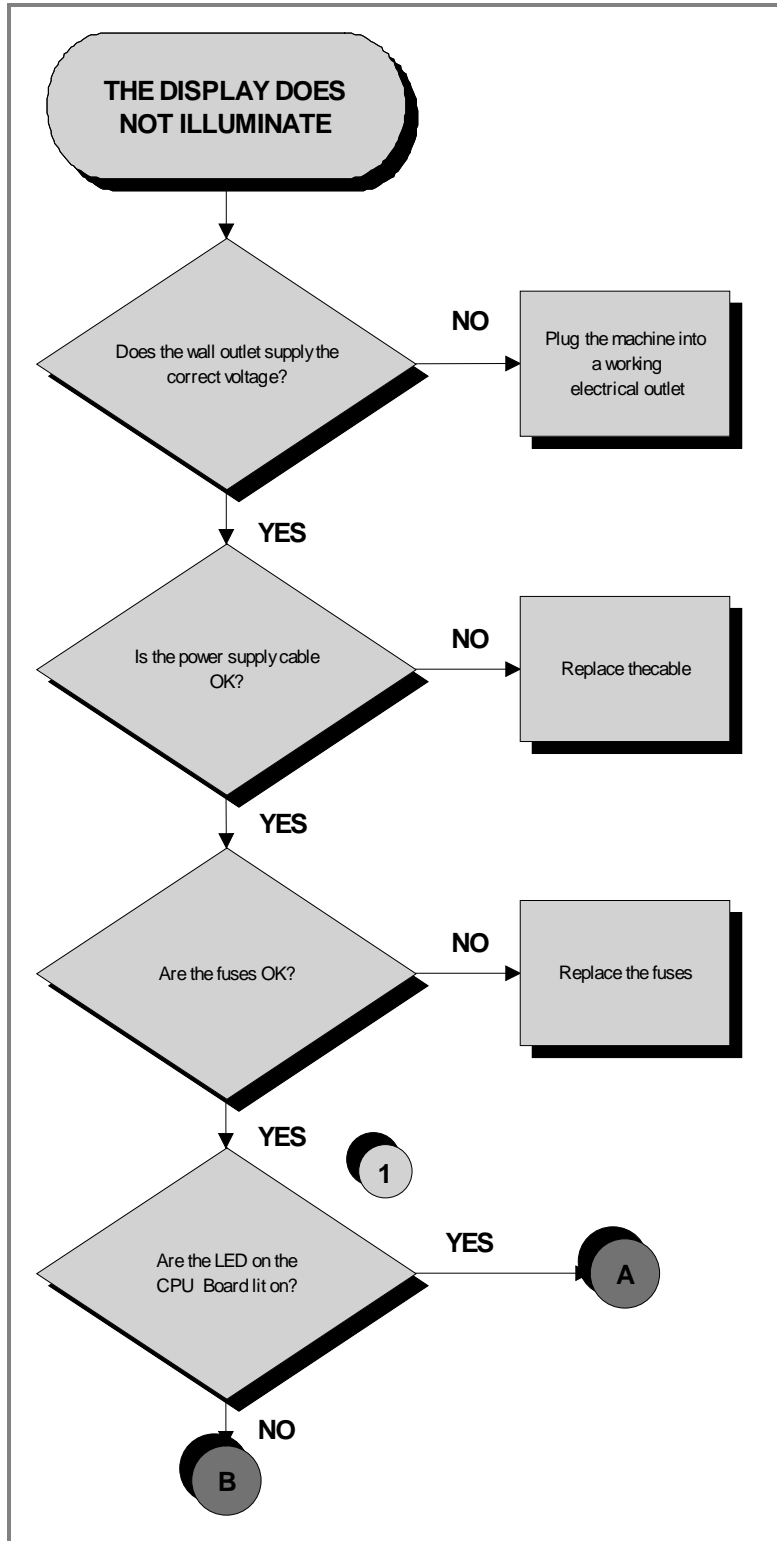


At the end, to check if the contacts inside of the fuse housing are intact and functioning, check the continuity of red cable (V+ battery). Carry out the measure on the CN3 connector of Brake Board and on the faston connector of battery. The result should be 0Ω (ohm).

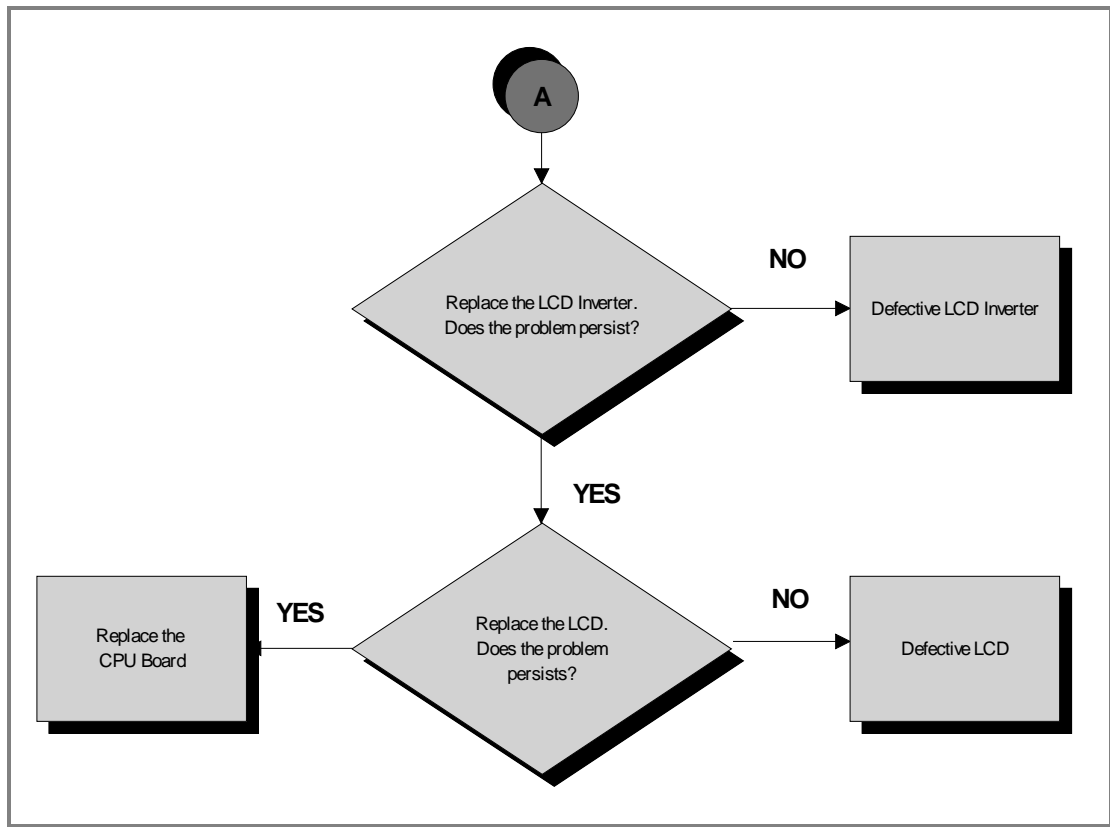


Figure 6.3-2

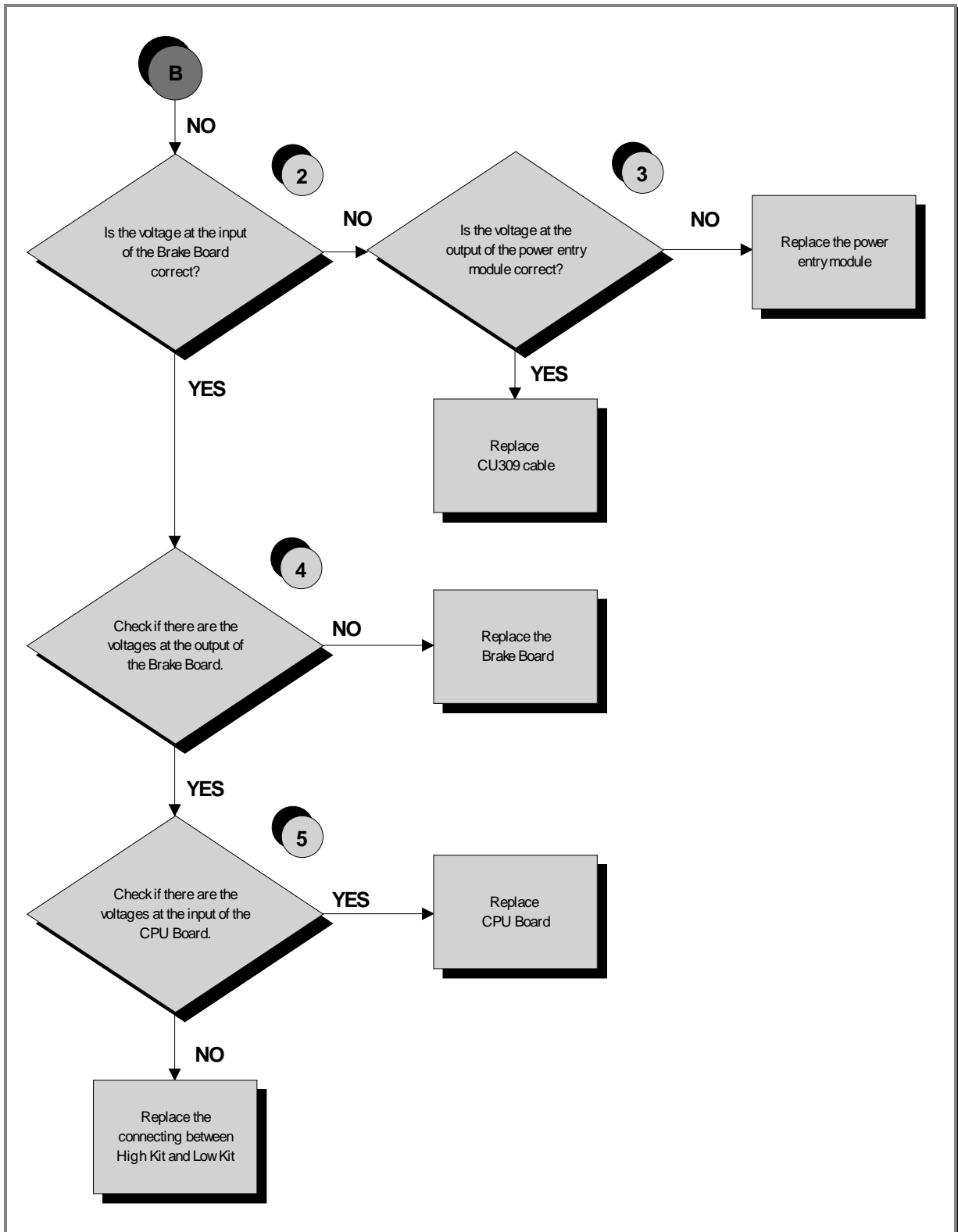
6.3.3. VISIO MODELS



Continued on following page ...



Continued on following page ...



Follow the procedure step by step to correctly diagnose the problem. Take particular care with the checks highlighted by circled numbers, which are described in detail below:

- (1) Check the **LED 1** (*green*) of the Display Board, is correctly lit on.
- (2) Place the tester probes across pins **3** and **1** of **CN4** connectors on the Brake board. The measured value should be approximately 220VAC or 110VAC depending on the mains voltage.
- (3) Slightly lift up the fast on the machine power entry module. Place the tester probes across the live and neutral pins on the same connector. The measured value should be approximately 220VAC or 110VAC depending on the mains voltage.
- (4) Using a tester, check that all the output voltages on connector **CN1** of the Brake board. The measured value should be:
 - +12Vdc between pins **6-2**;
 - +5Vdc between pins **7-3**.
- (5) Place the tester probes across pins **1** and **2** of **CN15** of Display Board. The measured value should be +12Vdc..




If you replace Display Board and/or Brake Board, check that its SW version is updated, otherwise install the last version.



The TV and RADIO channels are only stored in a file in the FLASH memory. Then the channels will be re-store the replacement of the CPU Board.


6.4. THE TOUCH SCREEN DOES NOT WORK / IT'S NOT CALIBRATED

 Only for VISIO models.

 For the following menu, please refer to the relevant chapter in the VISIO manual.


6.5. NO AUDIO SOUND

 Only for VISIO models.

 For the following menu, please refer to the relevant chapter in the VISIO manual.


6.6. NO TV PICTURE

 Only for VISIO models.

 For the following menu, please refer to the relevant chapter in the VISIO manual.

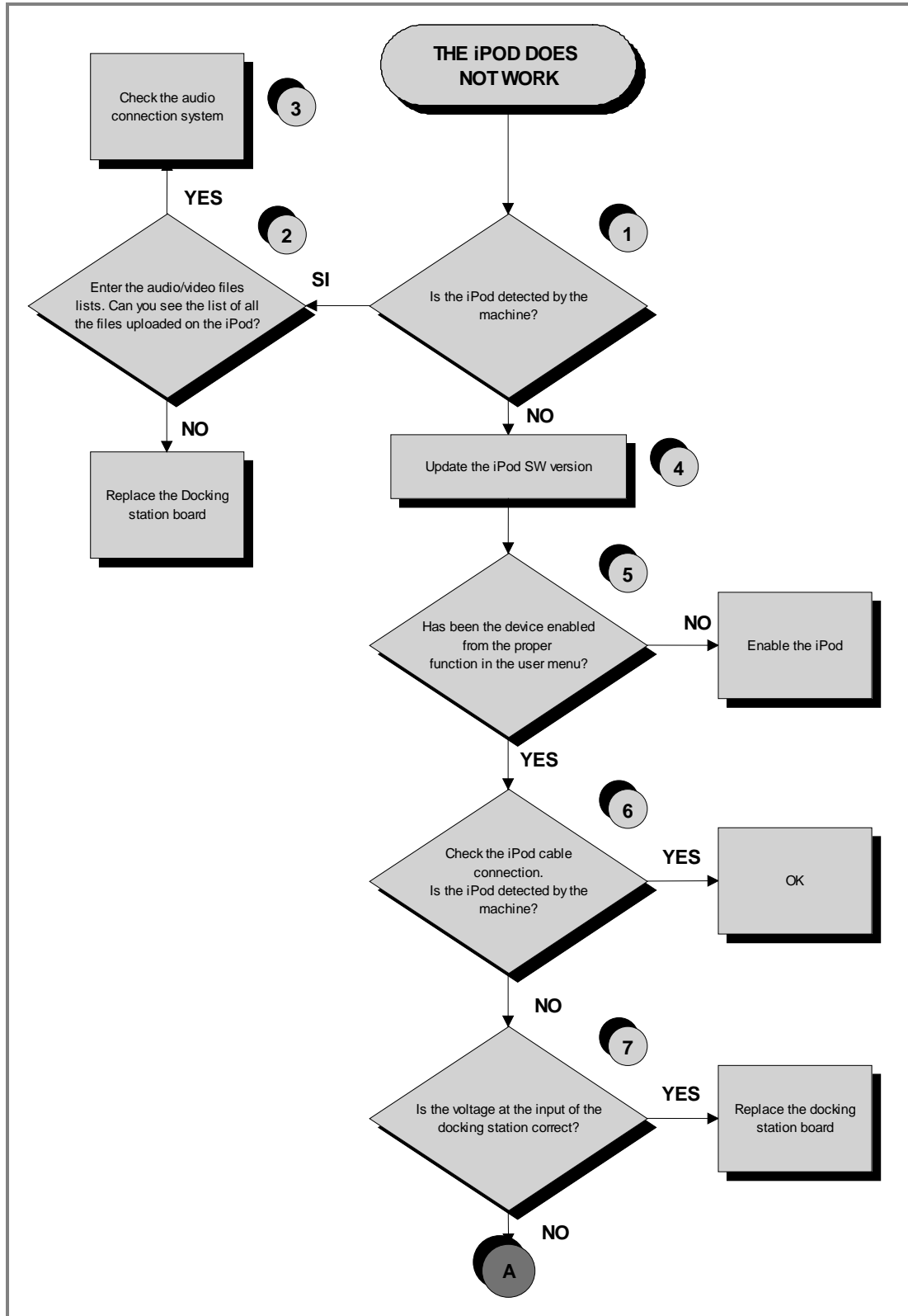
6.7. THE RADIO DOES NOT PLAY

 Only for VISIO models.

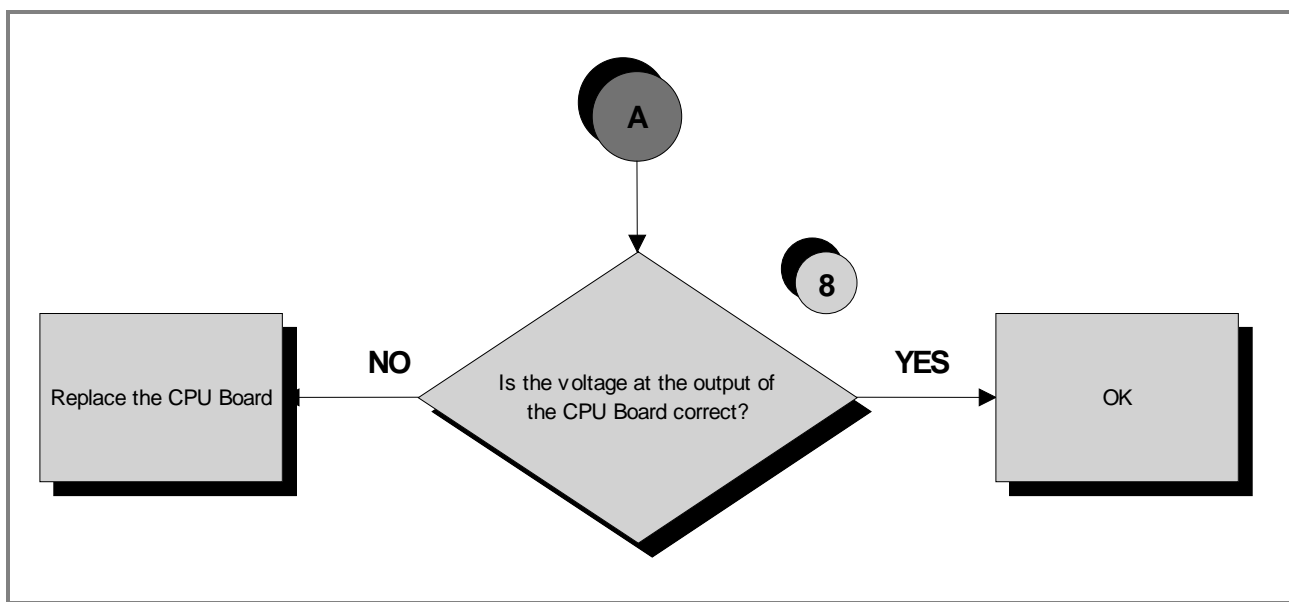
 For the following menu, please refer to the relevant chapter in the VISIO manual.

6.8. THE IPOD DOES NOT WORK

 Only for VISIO models.



Continued on following page....



Follow the procedure step by step to correctly diagnose the problem. Take particular care with the checks highlighted by circled numbers, which are described in detail below:

- (1) Switch on the machine, connect the iPod on the docking station and check that the device is correctly detected by the machine.
- (2) Check that the audio/video files uploaded in the iPod are visible and selectable through the VISIO interface.
- (3) Carry out the troubleshooting procedure: 6.5. “No audio sound”.
- (4) To update the iPod SW you just need to connect to iTunes and it automatically upgrades to the last version.
- (5) Enable the iPod control as detailed in the relevant paragraph of the User menu.
- (6) The **CU331** cable has identical connectors on either end then it can sometimes be connected the wrong way round.
- (7) Place the tester probes across pins **8** and **9** of the connector on the docking station board where the **CU331** cable is connected. The measured value should be 5Vdc.
- (8) As for step (7) but across pins **6** and **7** of the connector on the CPU board where **CU331** is connected.



If you replace CPU Board, check that its SW version is updated, otherwise install the last version.

6.9. MESSAGE ON DISPLAY “THE EQUIPMENT IS LOCKED (COM)”

This error message can be caused by loss of communication between the High Lit and Low Kit and a possible interruption during SW loading/upgrade.

The error is displayed by a message and stored in the “*Errors Log*” section.

To reinstate communications between the lower and upper assemblies:

- (1) Check that cables **ELT-06** and **ELT-07** is correct, using the *Test Box Excite* and replace if necessary.
- (2) Try replacing the Brake Board and the CPU/ARM Board in turn, and check whether the communication works.

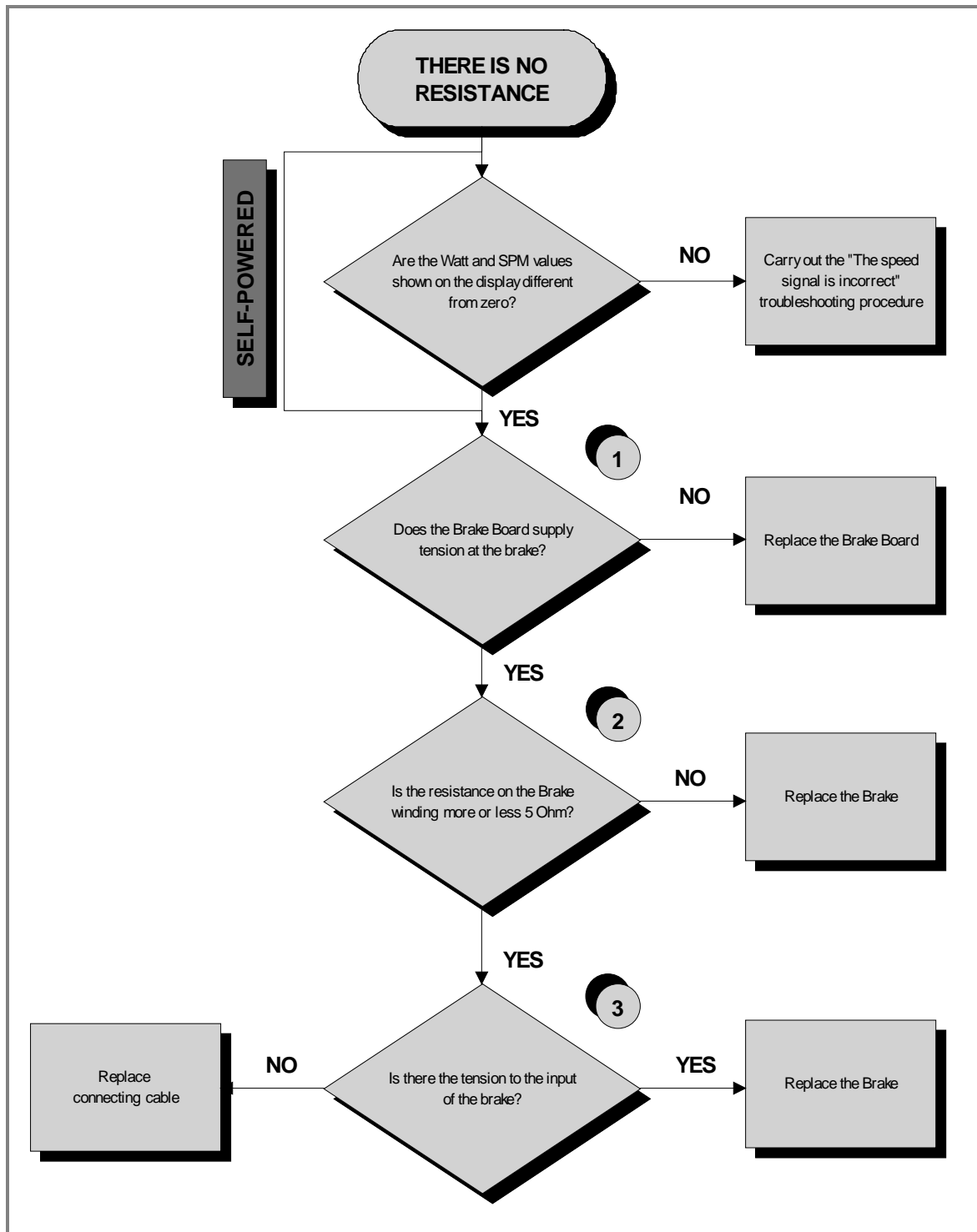


If you replace Brake Board, check that its SW version is updated, otherwise install the last version.

6.10. THERE IS NO RESISTANCE

The machine will not produce resistance if:

- the display board is not receiving a speed signal;
- the Brake Board is not generating current;
- the brake is defective.



Follow the procedure step by step to correctly diagnose the problem. Take particular care with the checks highlighted by circled numbers, which are described in detail below:

- (1) Place the tester probes across pins **1** and **2** of the connector **CN2** on the Brake Board and exercise at a speed of 60RPM. You should measure a Vdc which increases according to the exercise level.
- (2) Measure the resistance on the 2 fast on of the Brake.
- (3) As for step (1) but with everything reconnected, and across the Electromagnetic Brake.

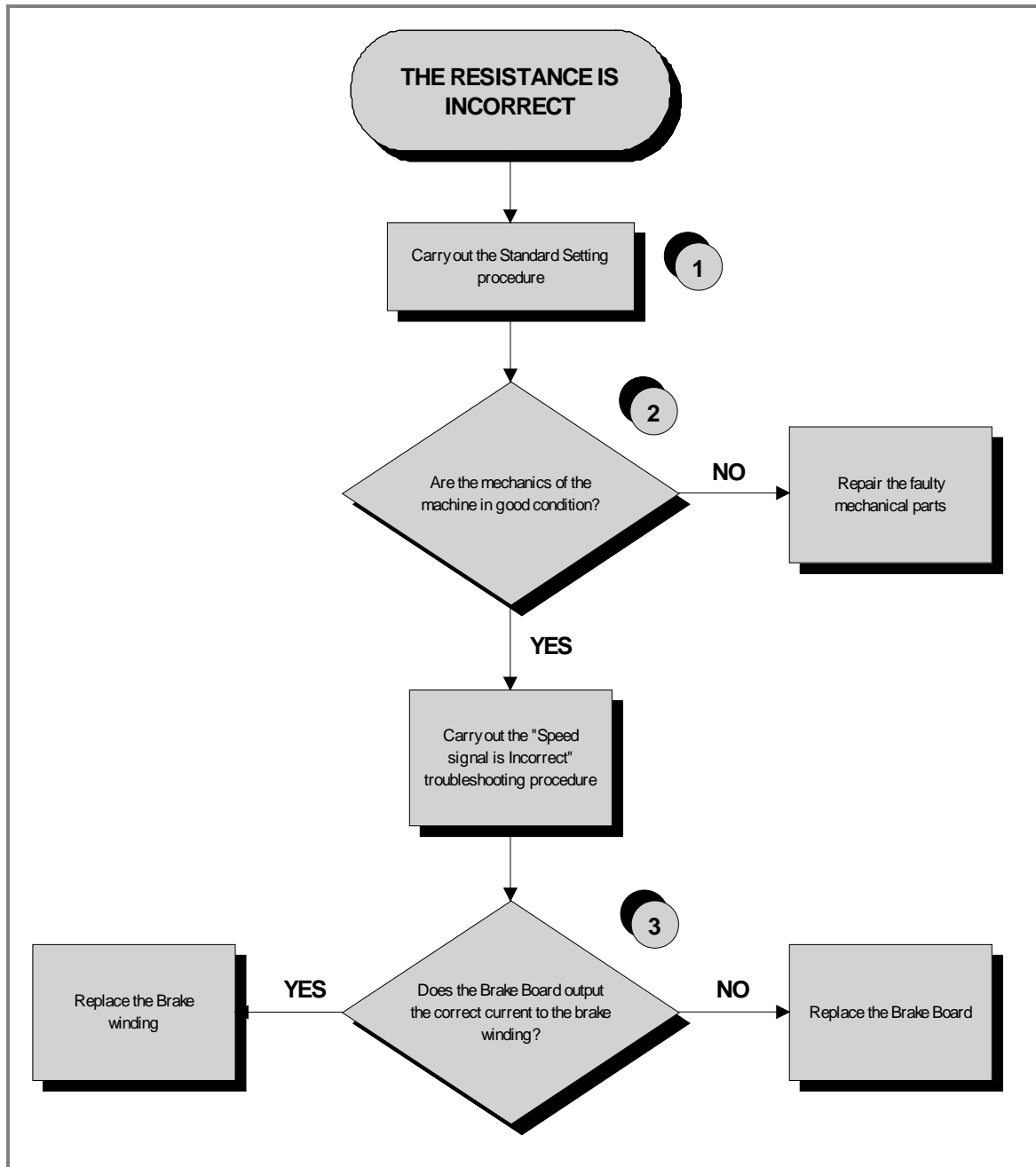


If you replace Brake Board, check that its SW version is updated, otherwise install the last version.

6.11. THE RESISTANCE IS INCORRECT

The machine will produce an incorrect resistance if:

- *the mechanical components are not in perfect condition;*
- *the speed measurement is incorrect;*
- *the Brake Board is defective;*
- *the brake is defective.*



Follow the procedure step by step to correctly diagnose the problem. Take particular care with the checks highlighted by circled numbers, which are described in detail below:

- (1) Carry out the *Standard Settings* procedure as detailed in the relevant paragraph of the Service menu.
- (2) Check that the mechanical system, consisting of the pedals, belt and brake, moves smoothly and without higher than normal friction or resistance.
- (3) Measure the voltage supplied by the Brake Board to the winding. In Quick Start mode, select the effort level and check that the value is different from 0.

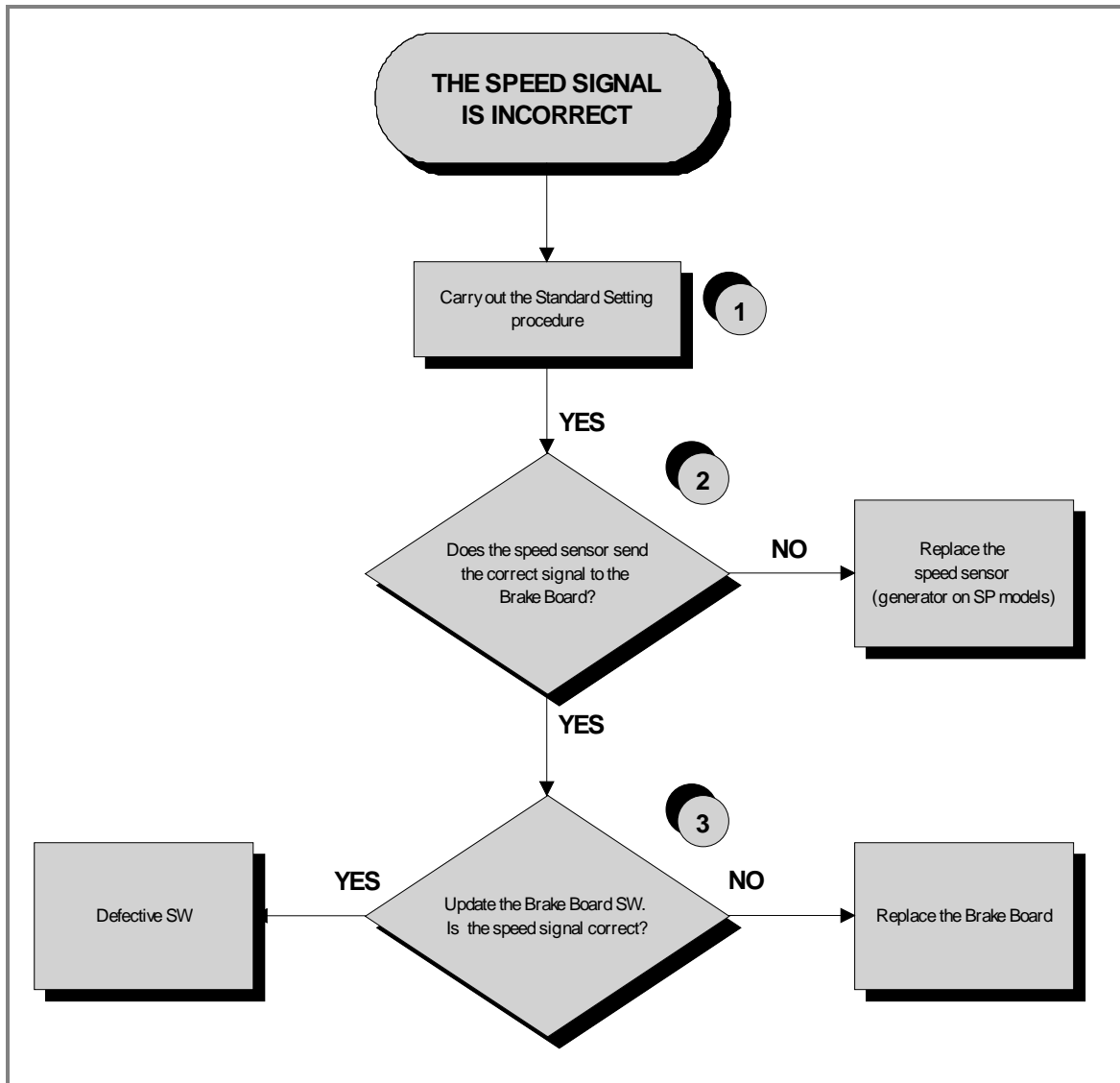


If you replace Brake Board, check that its SW version is updated, otherwise install the last version.

6.12. THE SPEED SIGNAL IS INCORRECT

The speed signal is incorrect if:

- *The brake disk is incorrectly fixed to the flywheel;*
- *The speed sensor is defective;*
- *The Brake Board is defective.*



Follow the procedure step by step to correctly diagnose the problem. Take particular care with the checks highlighted by circled numbers, which are described in detail below:

- (1) Carry out the *Standard Setting* procedure as detailed in the relevant paragraph of the Service menu.



The speed sensor detects the heads of these bolts.

- (2) **Powered models:** Place the tester probes across the terminals of the speed sensor. The measured signal should be that indicated in Figure 3.12-1. In addition, when pedalling at 80RPM the frequency of the signal should be 136Hz.
- (3) **Self-Powered models:** Check the signal at paragraph: 2.9. “Cables”. The measured signal should be that indicated in Figure 3.12-1 In addition, when pedalling at 80RPM the frequency of the signal should be 136Hz.



The speed signal can also be observed qualitatively, using a multimeter. The value should be 0Vdc when the machine is stopped, and gradually increase as the speed increases.

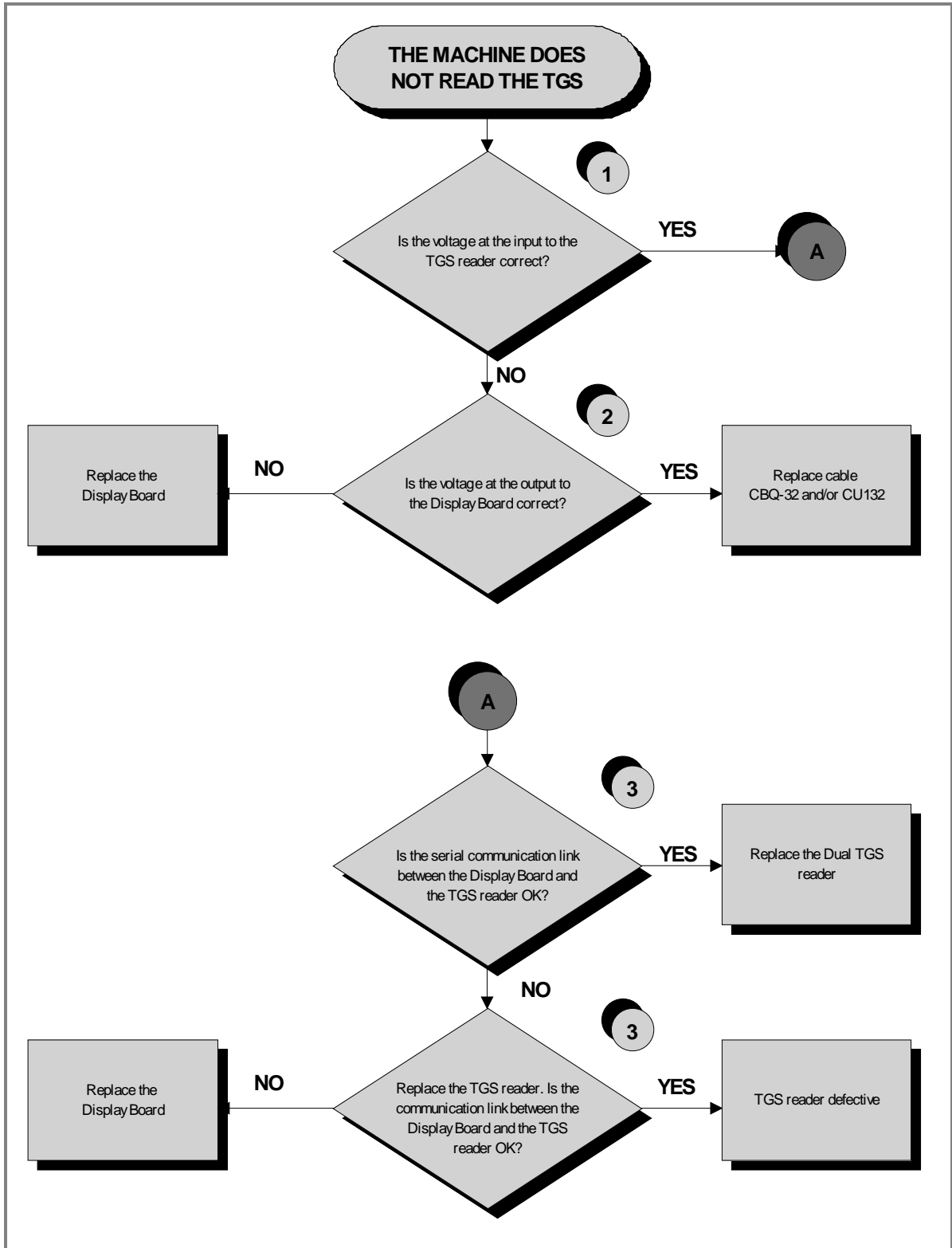
- (4) Update the low kit SW uploading both firmware and brake table. At the end carry out the Default setting procedure for the low kit parameters.



If you replace ARM/CPU Board and/or Brake Board, check that its SW version is updated, otherwise install the last version.

6.13. THE MACHINE DOES NOT READ THE TGS

The machine displays this error if the TGS reader is not working properly, or if it is not supplied by the CPU/ARM Board.



Follow the procedure step by step to correctly diagnose the problem. Take particular care with the checks highlighted by circled numbers, which are described in detail below:

- (1) In Place the tester probes across pins **1** and **3** of connector **CN1** of the TGS reader. The measured value should be +12Vdc.
- (2) As for step (1) but across pins **1** and **8** of connector **CN19** (CPU Board) or on the **CN7** connector (ARM Board).
- (3) Use the serial communications test described at paragraph: 6.1.3.3 “Serial Ports Test”.



If you replace ARM/CPU Board, check that its SW version is updated, otherwise install the last version.

6.14. THERE IS NO HEART RATE SIGNAL

6.14.1. HS RECEIVER (HAND SENSOR)

 700 models.



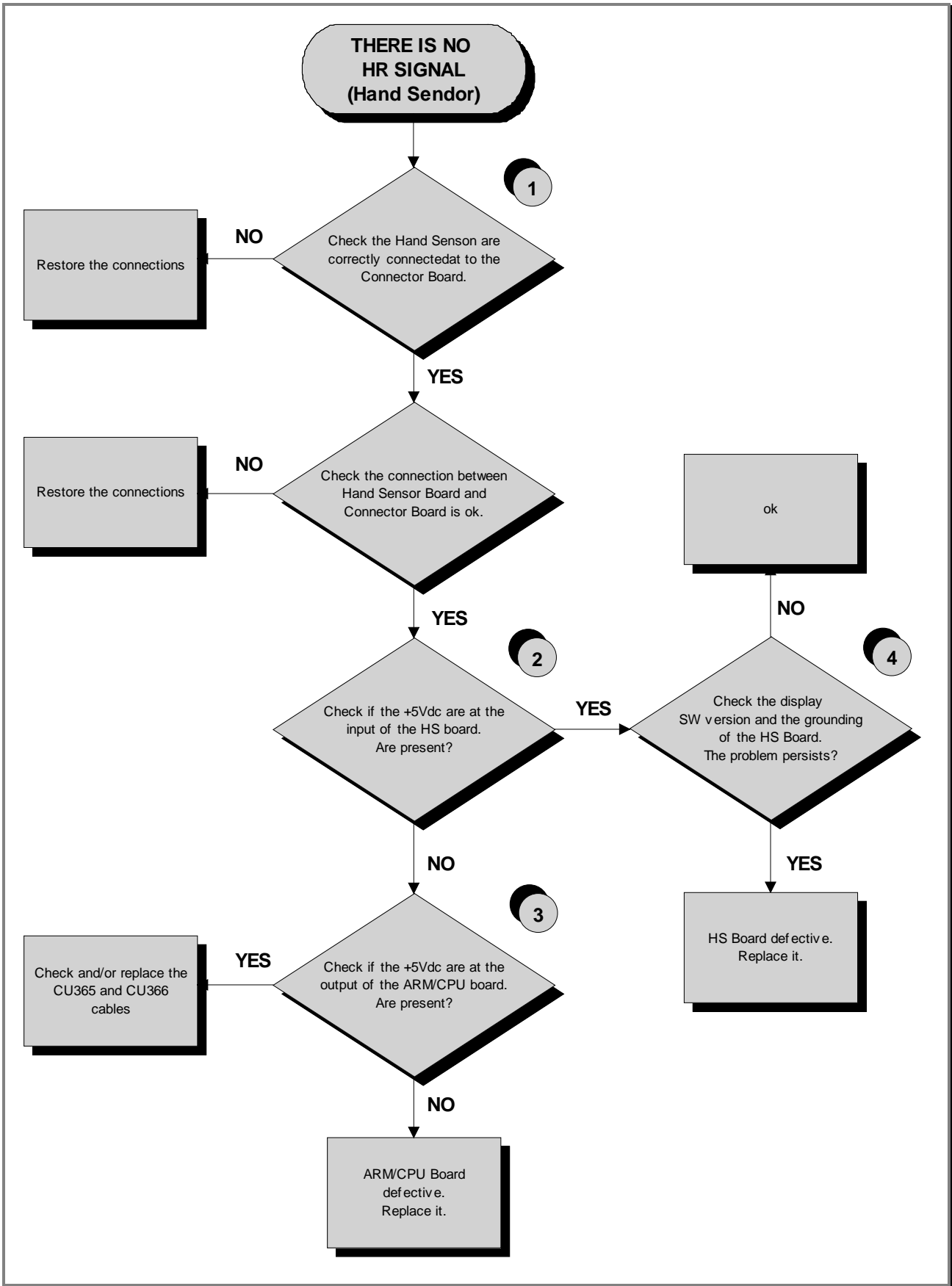
HUMAN BODY “CONTINUITY”: it’s well known that for somebody it’s very difficult, nearly impossible, to measure their HR using the hand sensors. This due to a lot of possible causes which could fake the “quality” of the contact between the human skin and the HS plates, as: hands only just washed or particularly dry, acidity of the skin and/or a particular body fat mass index. For these people it’s suggested to wear the chest belt transmitter.



HS CORRECT USE: Grasp both the upper and lower plate avoiding to clench them too hardly. Avoid to wash the hands using soaps that can dry the skin too much.

The machine displays this error if the **HS Receiver** does not work or is not powered by the CPU/ARM board:

Continued on following page ...



Continued on following page ...

Follow the procedure step by step to correctly diagnose the problem. Take particular care with the checks highlighted by circled numbers, which are described in detail below:

- (1) Check the continuity of the signal through two cables **ELT-10** and **ELT-31**: Check also they are correctly connected, referring to paragraph: 2.8. “Wiring diagrams”.
- (2) Place the tester probes across pins **1** and **2** on the connector **J3** of Hand Sensor Board. The measured value should be +5Vdc.
- (3) As at step (2) but on pin **1** and **6** on **CN4** connector (*ARM Board*) and on **CN23** connector (*CPU Board*).
- (4) Check the correct display SW version, according to the “EXCITE SW SMART TABLE” you can find in **TG Direct** ,“NEWS” section.

Check the grounding of the **Hand Sensor Board (HS)**, measuring the resistance value between:

- a. *The Faston on the HS Board and the ground node on the equipment;*
- b. *The ground node of the equipment and the main wall socket.*

The measured value should be approximately lower than 1Ω (Ohm).

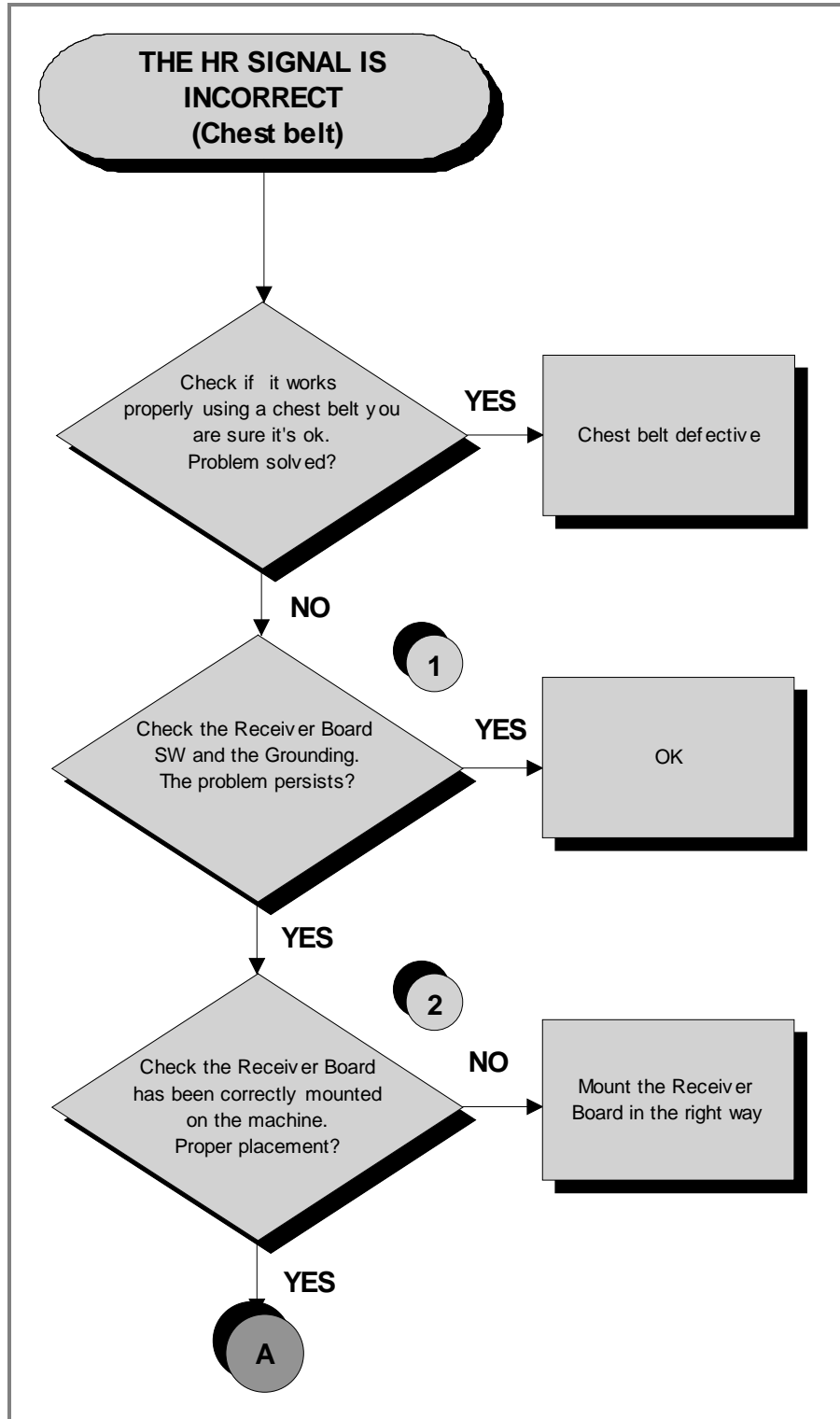
Check finally the grounding of the main wall socket, measuring that the following voltages are present:

P – N (phase – neutral) = 220Vac / 110 Vac
P – G (phase – ground) = 220Vac / 110 Vac
N – G (neutral – ground) = 0 Vac

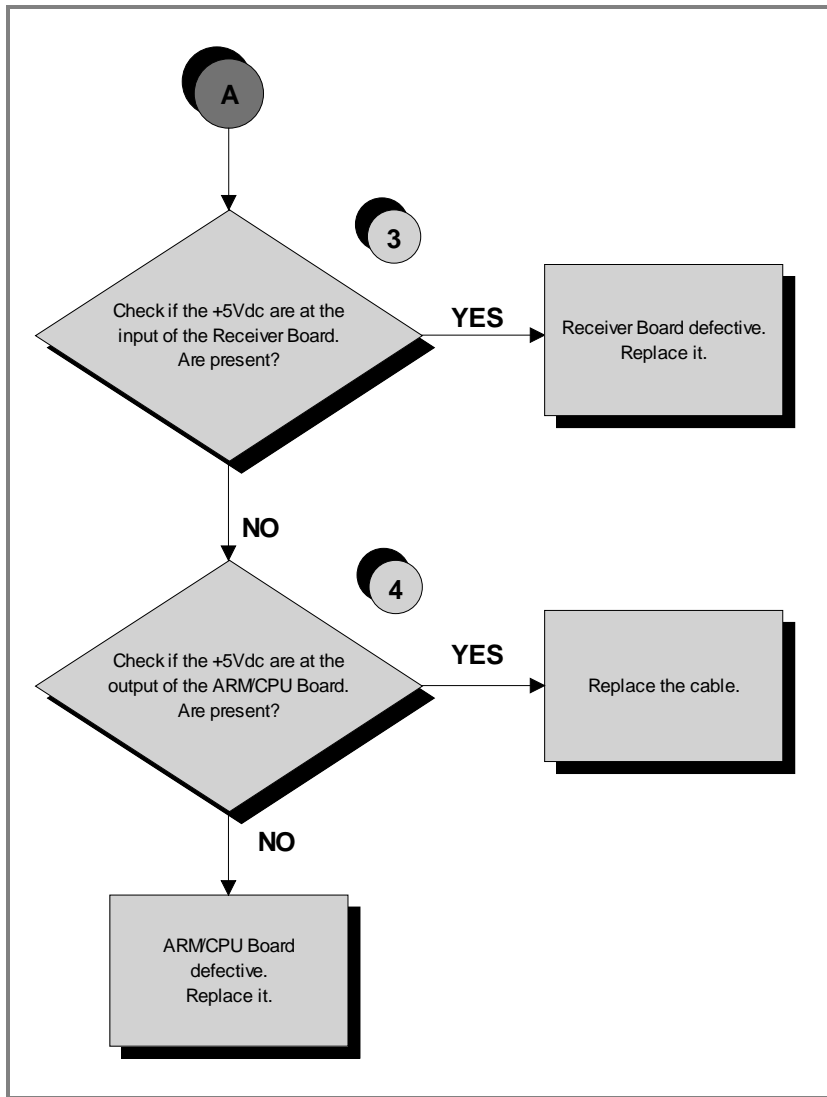
6.14.2. HR RECEIVER (CHEST BELT)



CORRECT USE OF THE CHEST BELT: Wear the chest belt taking care the area of contact with the body is humid in order to guarantee it proper works.



Continued on following page ...



Continued on following page ...

Follow the procedure step by step to correctly diagnose the problem. Take particular care with the checks highlighted by circled numbers, which are described in detail below:

- (1) Check the correct display SW version, according to the “EXCITE SW SMART TABLE” you can find in **TG Direct** section.

Check the grounding of the **HR Receiver Board**, measuring the resistance value between:

- c. The Faston on **Receiver Board** and the ground node on the equipment;
 d. The ground node on the equipment and the main wall socket t.

The measured value should be approximately lower than 1Ω (Ohm).

Check finally the grounding of the main wall socket, measuring that the following voltages are present:

P – N (phase – neutral) = 220Vac / 110 Vac
P – G (phase – ground) = 220Vac / 110 Vac
N – G (neutral – ground) = 0 Vac

- (2) Check if the receiver has been correctly mounted on the machine, as detail at paragraph: 7.4. “Disassembling the cardio receiver”.
- (3) Place the tester probes across pins **1** and **2** of **CN1** connector of receiver. The measured value should be +5Vdc.
- (4) As at step (3) but on pin **1** and **8** on **CN3** connector (*ARM Board*) and on **CN29** connector (*CPU Board*).



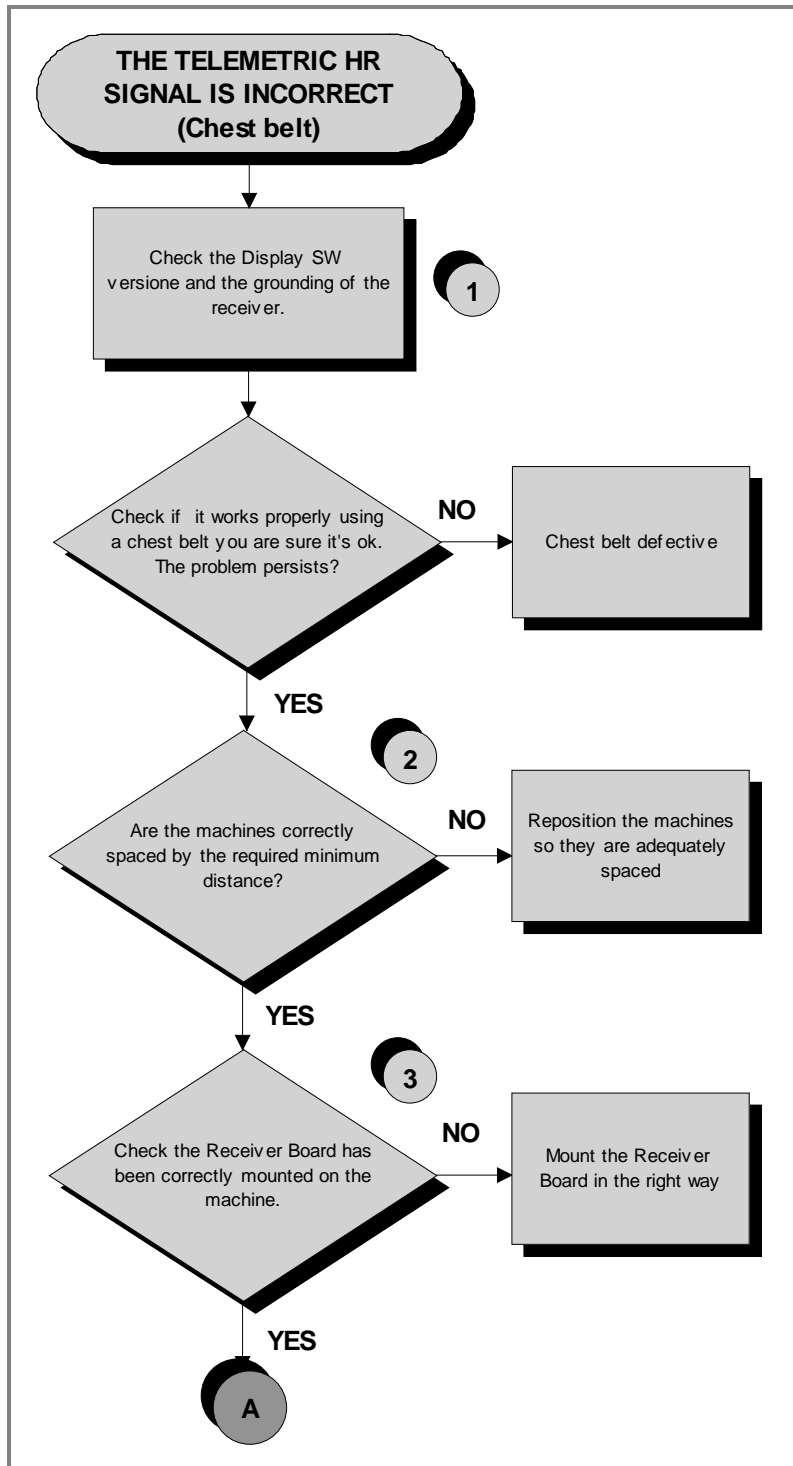
If you replace CPU/ARM Board, check that its SW version is updated, otherwise install the last version.

6.15. THE TELEMETRIC HEART RATE SIGNAL IS INCORRECT

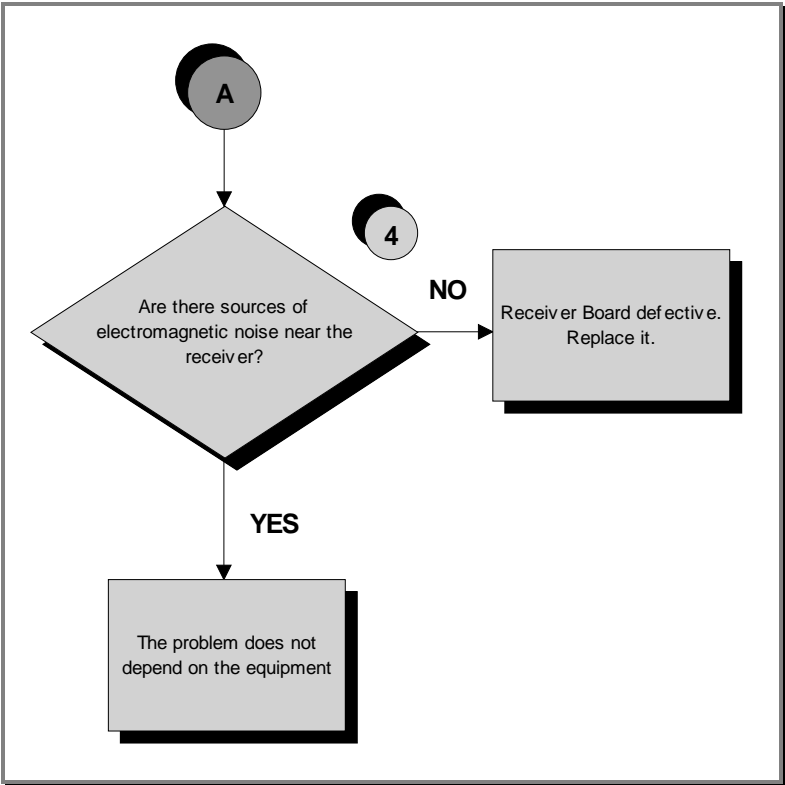
6.15.1. CHEST BELT



CORRECT USE OF THE CHEST BELT: Wear the chest belt taking care the area of contact with the body is humid in order to guarantee it proper works.



Continued on following page....



Follow the procedure step by step to correctly diagnose the problem. Take particular care with the checks highlighted by circled numbers, which are described in detail below:

- (1) Check the correct display SW version, according to the “EXCITE SW SMART TABLE” you can find in **TG Direct** section.

Check the grounding of the **HR Receiver Board**, measuring the resistance value between:

- The ground faston of Receiver Board and the ground node on the Power supply box of the machine;
- The ground node on the Power supply box of the machine and the main wall socket.

The measured value should be approximately lower than 1Ω (Ohm).

Check finally the grounding of the main wall socket, measuring that the following voltages are present:

P – N (phase – neutral) = 220Vac / 110 Vac
P – G (phase – ground) = 220Vac / 110 Vac
N – G (neutral – ground) = 0 Vac

- (2) Take care of the following diagram to correctly position the machines:

Continued on following page....

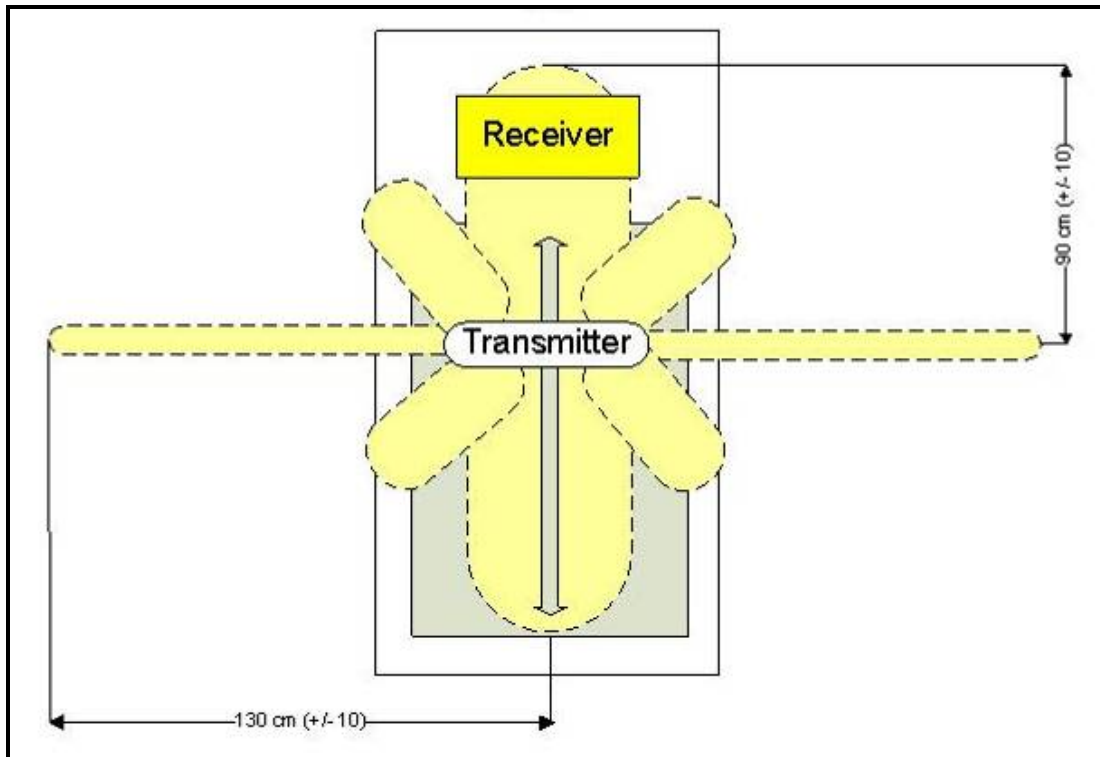


Figure 6.15-1



The active area of the transmitter is wider on the lateral side (130 cm) instead of the front or the back side (90 cm). Take care of the following diagram:

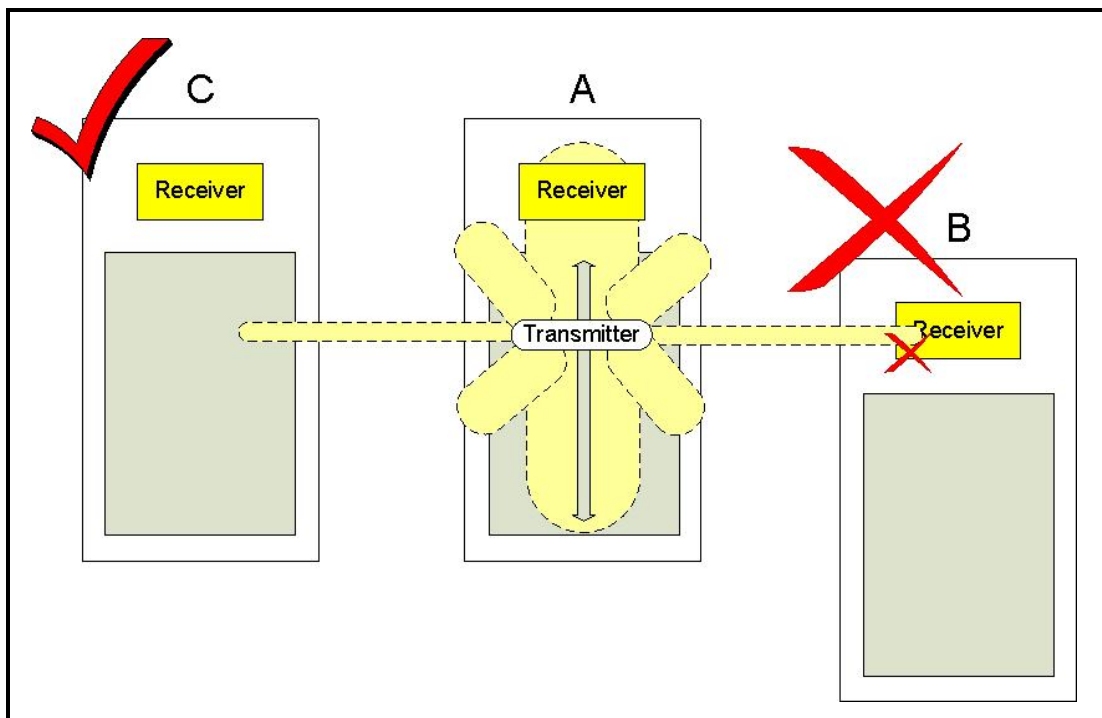
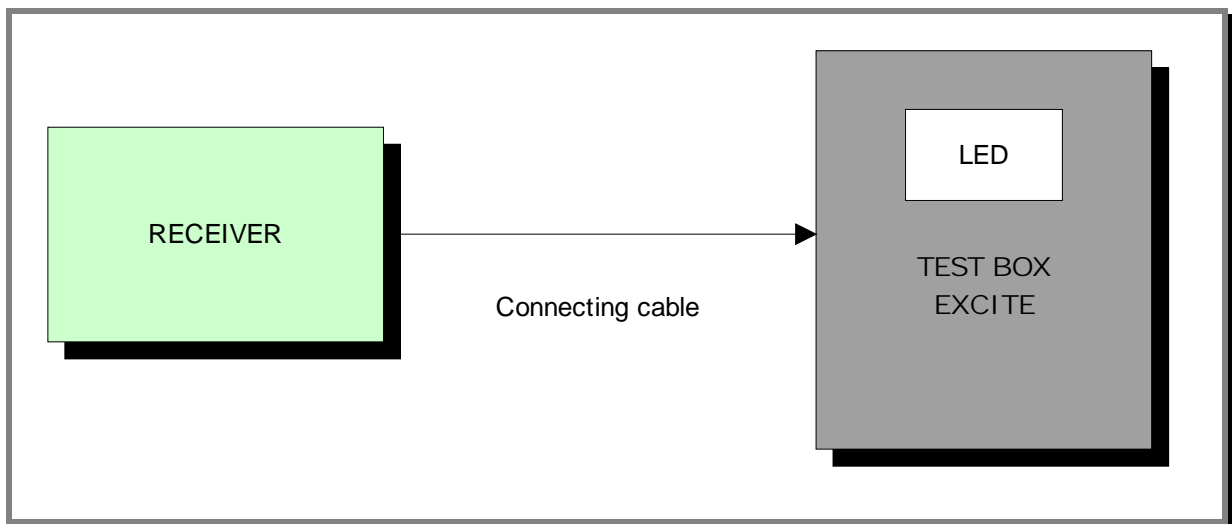


Figure 6.15-2

- (3) Check if the receiver has been correctly mounted on the machine, as detail at paragraph: 7.4. “Disassembling the cardio receiver”.
- (4) To check for electromagnetic noise near the machine, use Test Box Excite as detailed here below. You can use one of the following cables **ELT-16** (0WC00518AB), **CBQ-28** (0WC00390AC) or **TRM-28** (0WC00336AC) as connection cable.



The circuit lights the LED for each heart beat and/or disturbance received: in this way it is possible to determine whether there is any interference, and identify its sources.



Do not keep the Test Box Excite too close to the display, to avoid the electric interference.

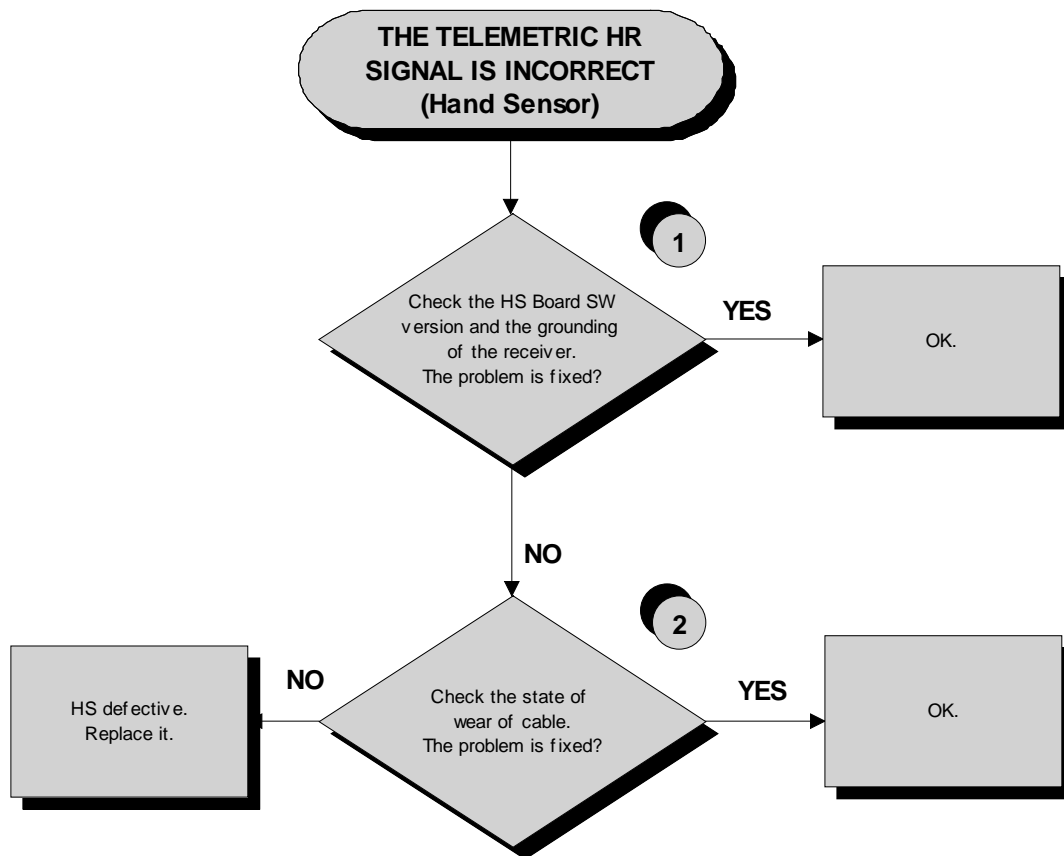
6.15.2. HAND SENSOR



HUMAN BODY “CONTINUITY”: it’s well known that for somebody it’s very difficult, nearly impossible, to measure their HR using the hand sensors. This due to a lot of possible causes which could fake the “quality” of the contact between the human skin and the HS plates, as: hands only just washed or particularly dry, acidity of the skin and/or a particular body fat mass index. For these people it’s suggested to wear the chest belt transmitter.



HS CORRECT USE: Grasp both the upper and lower plate avoiding to clench them too hardly. Avoid to wash the hands using soaps that can dry the skin too much.



Follow the procedure step by step to correctly diagnose the problem. Take particular care with the checks highlighted by circled numbers, which are described in detail below:

- (1) Check the correct display SW version, according to the “EXCITE SW SMART TABLE” you can find in **TG Direct**, section.

Check the grounding of the receiver board, measuring the resistance value between:

- a. The Faston on **Hand Sensor Board** and the ground node on the equipment;
- b. The ground node on the equipment and the main wall socket.

The measured value should be approximately lower than 1Ω (Ohm).

Check finally the grounding of the main wall socket, measuring that the following voltages are present:

P – N (phase – neutral) = 220Vac / 110 Vac
P – G (phase – ground) = 220Vac / 110 Vac
N – G (neutral – ground) = 0 Vac

- (2) Check that:

- a. the fastons of the cable are well connected to the HS plates;
- b. The continuity of the signal between the Hand Sensor plates and the relevant pin on **J2 – J3 – J4** connectors, of the Connector Board, on the **ELT-10, ELT-31 and ELT-19** cables, referring to the paragraph: 2.9. “Cables”;
- c. There is **NO** continuity between the HS plates and the ground faston on the receiver (otherwise the signals are grounded).

Page intentionally left blank.

7. DISASSEMBLY OF COMPONENTS

7.1. DISASSEMBLING THE DISPLAY

7.1.1. 500 AND 500SP VERSION

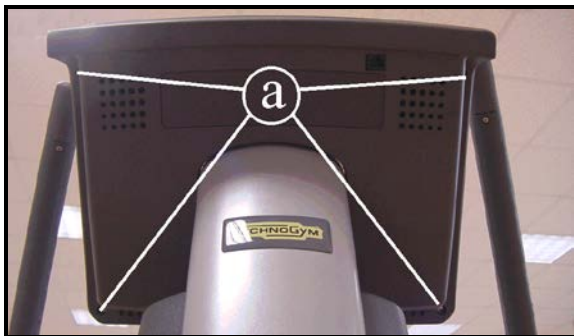


Figure 7.1-1

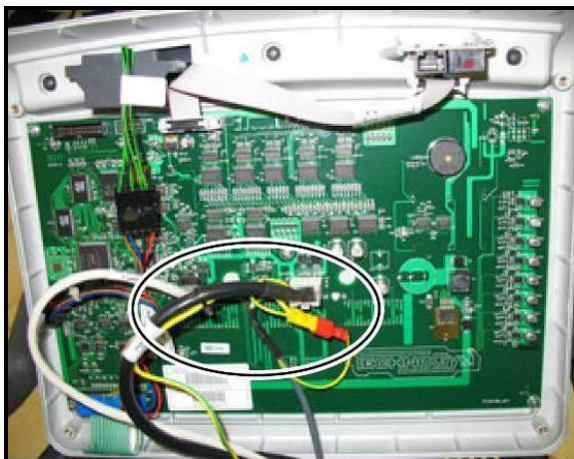


Figure 7.1-2



Figure 7.1-3

Turn off the machine and unplug the mains lead from the wall outlet:

1. Back off the 4 screws **(a)** using a medium Phillips screwdriver.

2. Unplug the connector highlighted in the figure at the side.

3. Remove the Display.

4. Back off the 2 screws **(b)**, using a 8mm hexagonal wrench, for remove the rear support of the Display.

To reassemble the Display, carry out the above steps in reverse order.

7.1.2. 700 AND 700SP VERSION

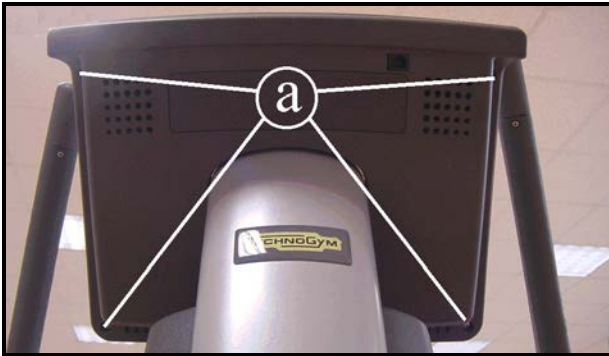


Figure 7.1-4

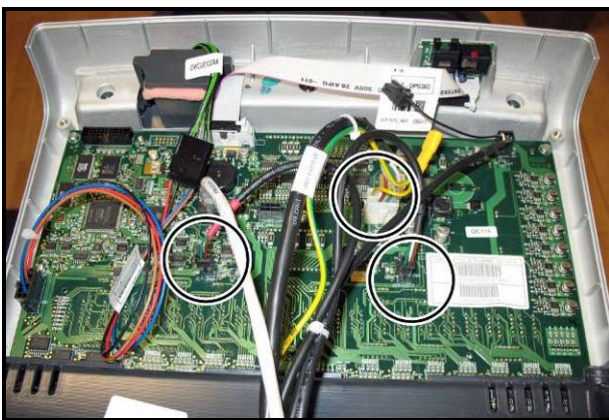


Figure 7.1-5

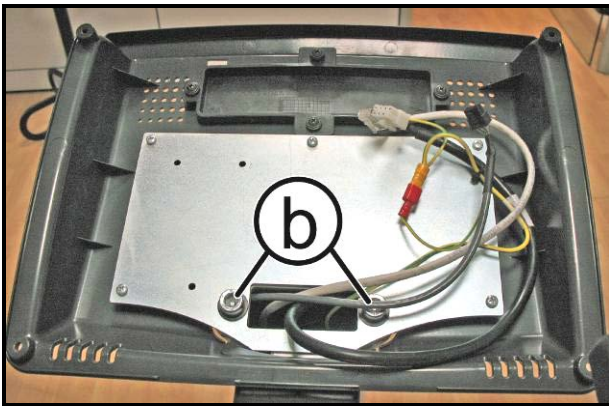


Figure 7.1-6

Turn off the machine and unplug the mains lead from the wall outlet:

1. Back off the 4 screws (a) using a medium Phillips screwdriver.
2. Unplug the connector highlighted in the figure at the side.
3. Remove the Display.
4. Back off the 2 screws (b), using a 8mm hexagonal wrench, for remove the rear support of the Display.

To reassemble the LED Display, carry out the above steps in reverse order.

7.1.3. 700VISIO VERSION

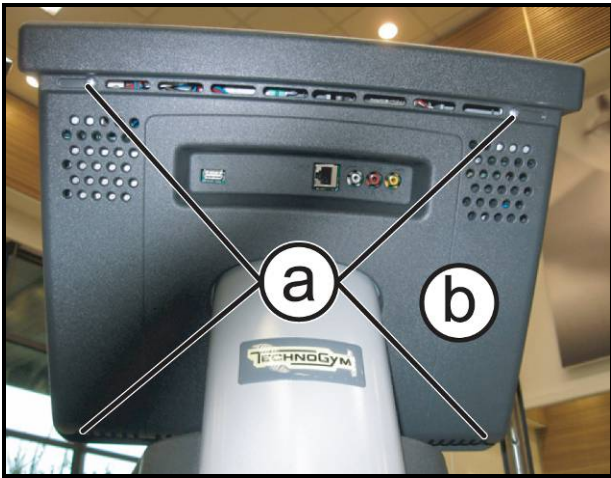


Figure 7.1-7

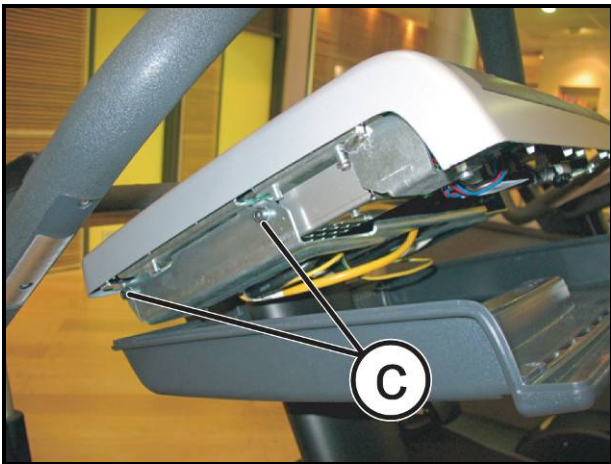


Figure 7.1-8

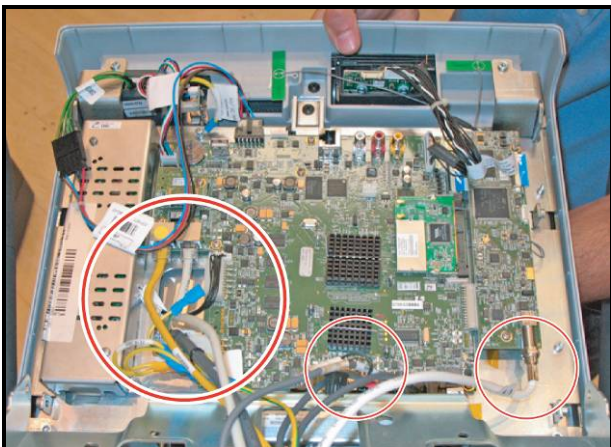


Figure 7.1-9

Turn off the machine and unplug the mains lead from the wall outlet:

1. Back off the 4 screws (a) using a medium Phillips Screwdriver.
2. Lower the guard (b).
3. Back off the 2 screws (c) using a 3mm hexagonal wrench, on both side.
4. Unplug the connectors highlighted in the figure at the side.
5. Remove the Display.

CAUTION: Connect the network cables (on the left in the photo) correctly, because they may not be inverted.

To reassemble the VISIO Display, carry out the above steps in reverse order.

7.2. DISASSEMBLING BOARDS AND COMPONENTS

7.2.1. LED DISPLAY (ARM BOARD)

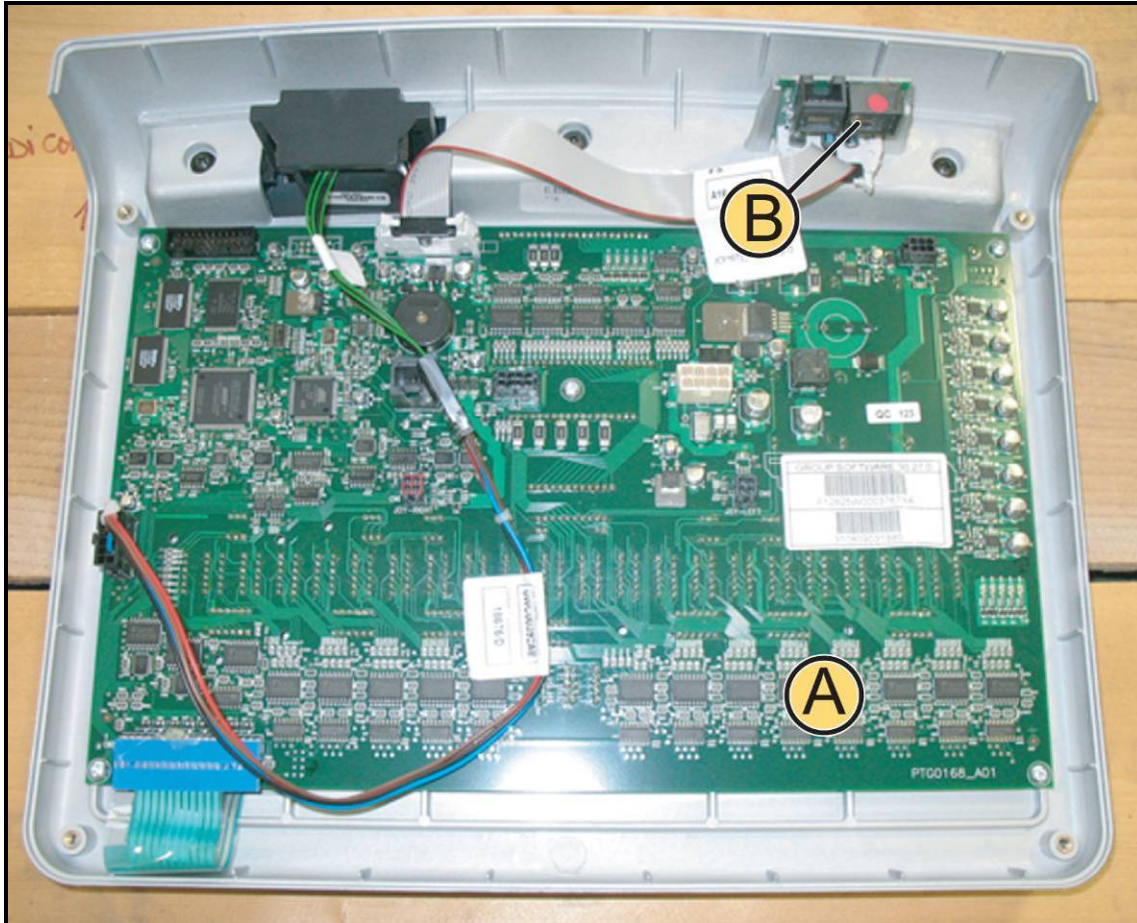


Figure 7.2-1

Carry out the procedure described in paragraph: 7.1. “Disassembling the display”.

Place the Display on a work bench:

It is now possible to remove the following boards:

- *The ARM board (A);*
- *The C-Safe board (B).*

7.2.1.1. ARM board (A)

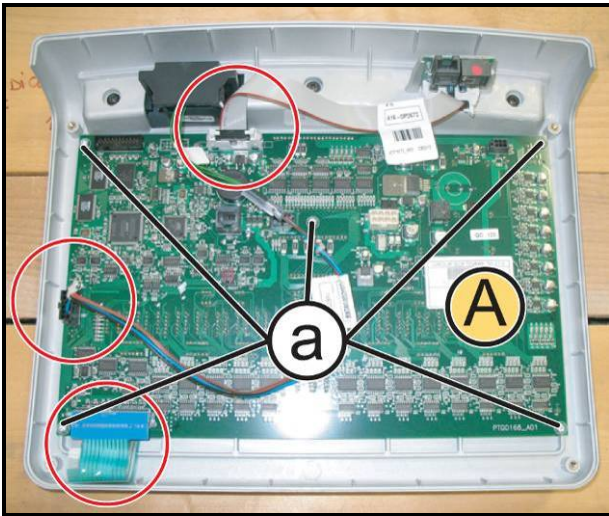


Figure 7.2-2

1. Unplug the connectors highlighted in the figure.
2. Back off the 5 screws (c) using a medium Phillips Screwdriver.
1. Remove the ARM board (A).

To reassemble the ARM board, carry out the above steps in reverse order.

7.2.1.2. C-Safe board (B)

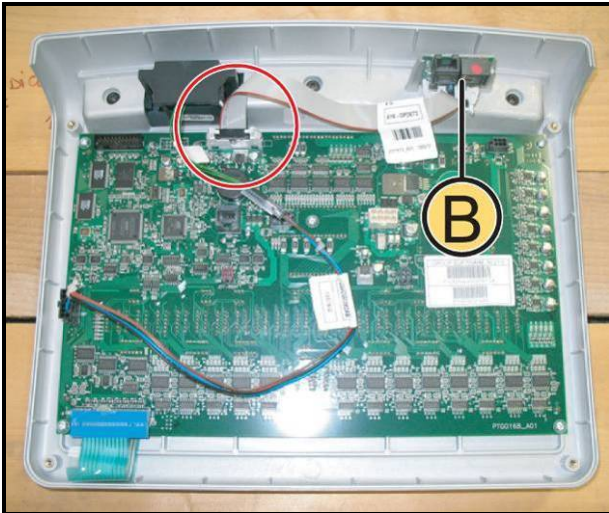


Figure 7.2-3

1. Disconnect from the ARM board the connector highlighted in the figure.
2. Remove the hot glue that fix the board on the casing and remove the C-Safe board (B), sliding it upward.



During the reassembly, use the hot glue to fix the C-Safe board.

To reassemble the C-Safe board, carry out the above steps in reverse order.

7.2.2. VISIO DISPLAY 15" (CPU BOARD)

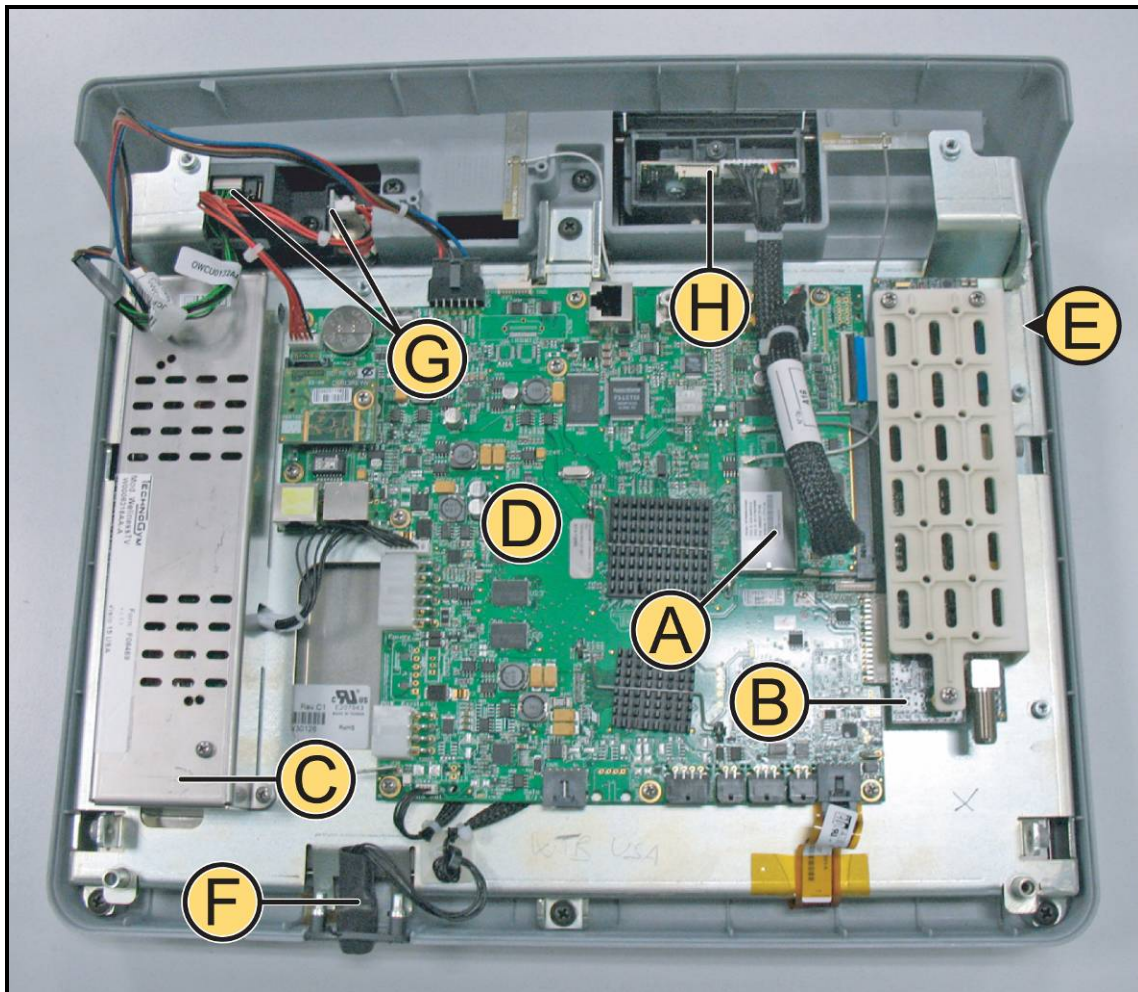


Figure 7.2-4

Carry out the procedure described in paragraph: 7.1. "Disassembling the display".

Place the display on a work bench:

It is now possible to remove the following components:

- *Wireless Board (A);*
- *TUNER Board (B);*
- *LCD Inverter (C);*
- *CPU board (D);*
- *LCD + Touch Screen (E);*
- *Headphone Jack (F);*
- *Dual TGS reader+ USB port (G);*
- *iPod Docking Station (H);*
- *Front plugs TGS + USB and cover.*

Continued on following page...

7.2.2.1. Wireless board (A)

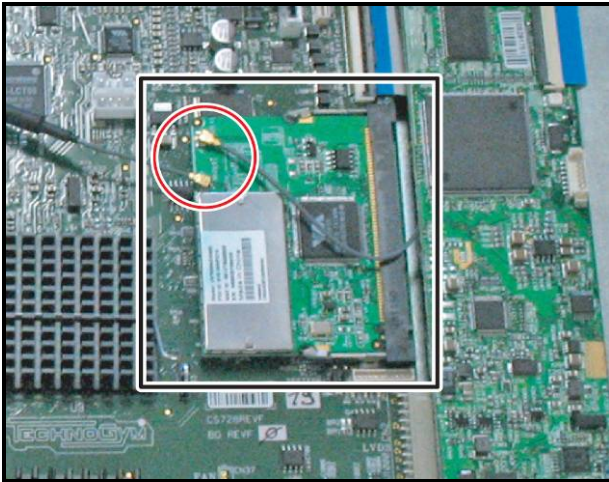


Figure 7.2-5

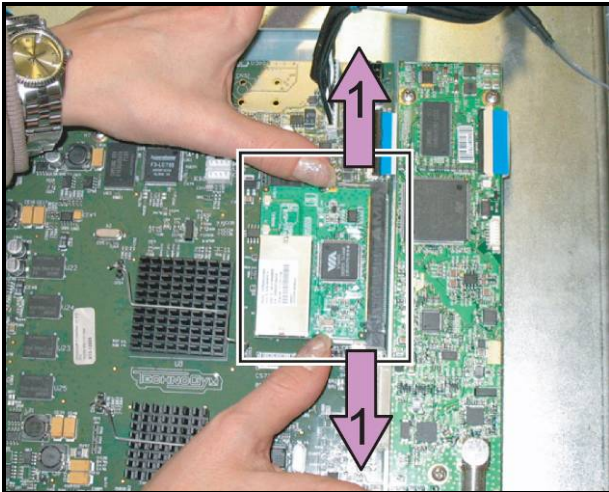


Figure 7.2-6

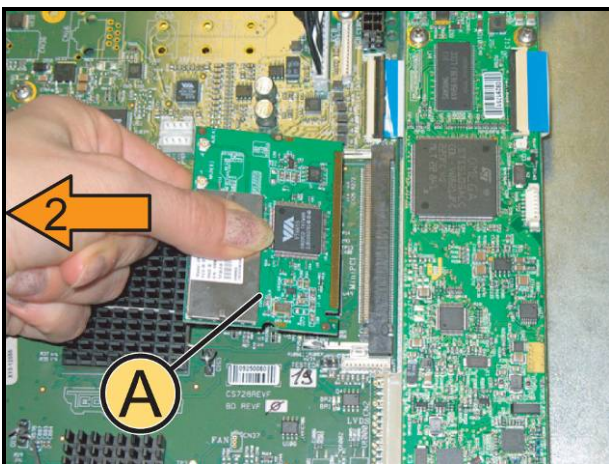


Figure 7.2-7

1. Unplug the 2 antenna connectors of the wireless board, highlighted in the figure.



CAUTION: Pay particular attention to the wireless antenna cables and connectors, because extremely sensitive, moreover in case of disassembly, it is important to follow the cable routing as shown in Figure 7.2-8.

2. Push simultaneously the 2 side tabs outward, in the direction of the purple arrows (1). The Wireless Board will automatically lift up


3. Remove the Wireless Board (A) in the direction of the orange arrow (2), as shown in the figure at the side.



CAUTION: During the reassembly, mount the antennas of Figure 7.2-5 on Wireless Board and after the Board in its housing; so not press on the CPU circuits.

To reassemble the Wireless Board, follows the above steps in the reverse order.

Continued on following page ...

 To reassemble the antenna cables (X) and (Y), follow the routing shown below.

 The Dissipator (Z) is only on the ATSC and ISDB-T version.

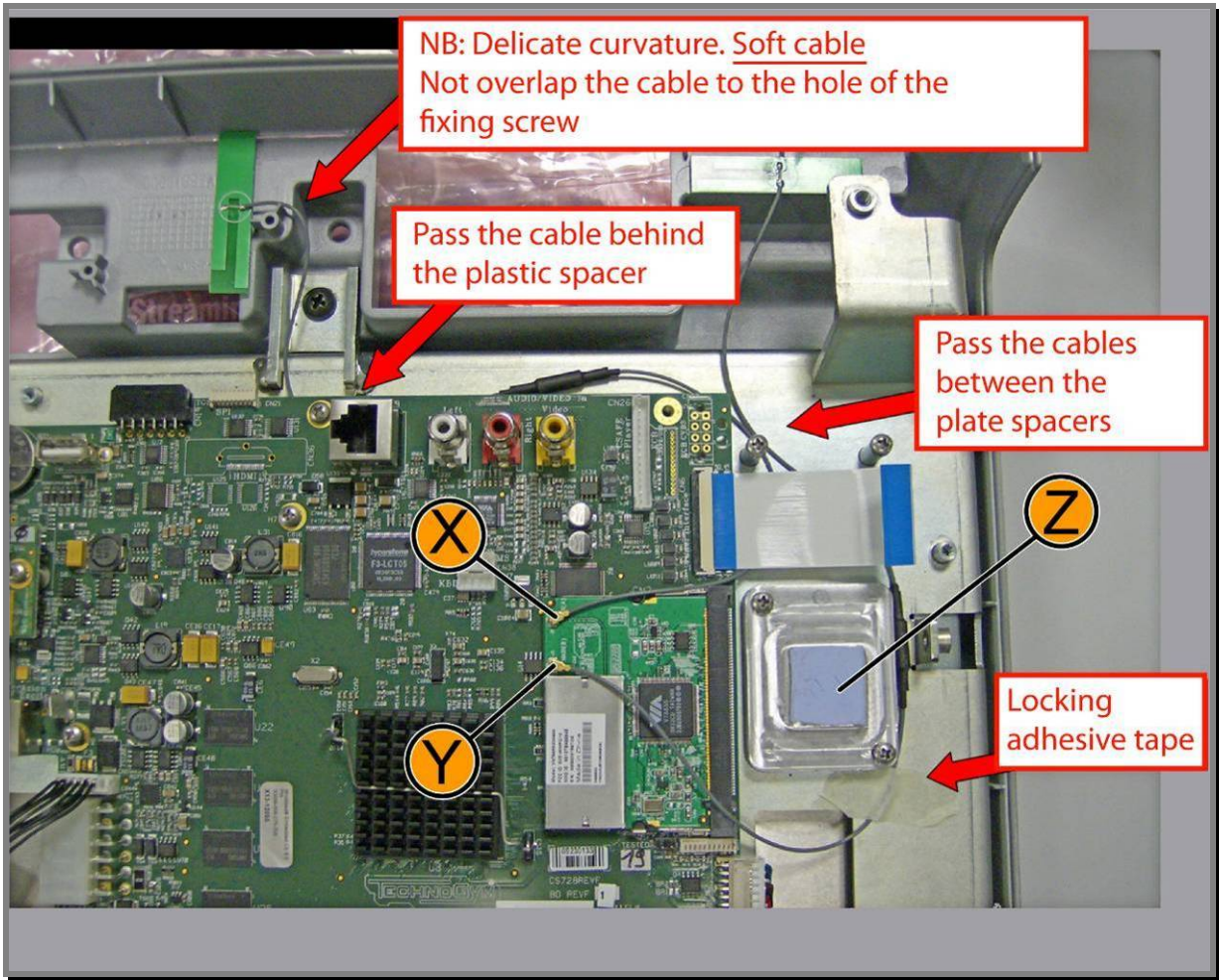


Figure 7.2-8

7.2.2.2. Tuner DVB-T board (B)

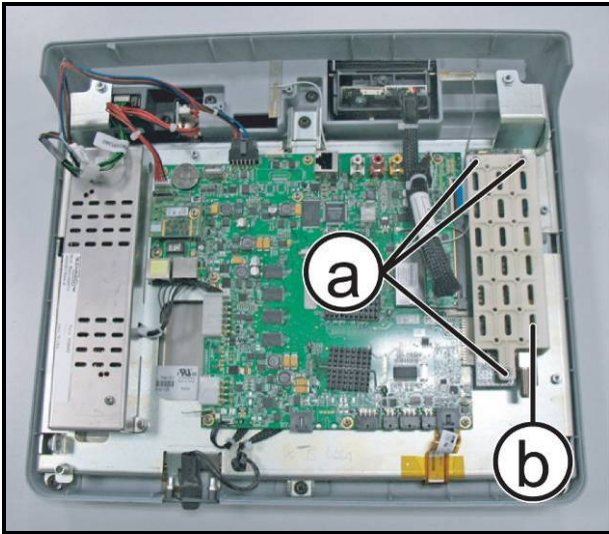


Figure 7.2-9

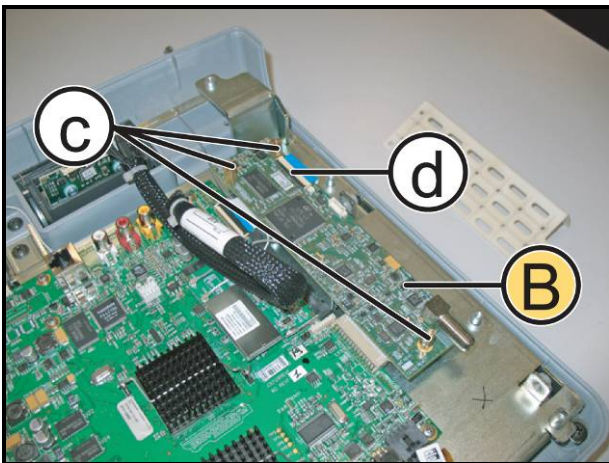


Figure 7.2-10

1. Back off the 3 screws (a) using a medium Phillips Screwdriver.
2. Remove the protection guard of Tuner board (b).
3. Back off the 3 spacers (c).
4. Lift up the black tab and disconnect the flat cable (d).
5. Remove the Tuner Board (B).

To reassemble the Tuner Board, follows the above steps in the reverse order.

7.2.2.3. Tuner board ATSC (B1) and ISDB-T (B2)

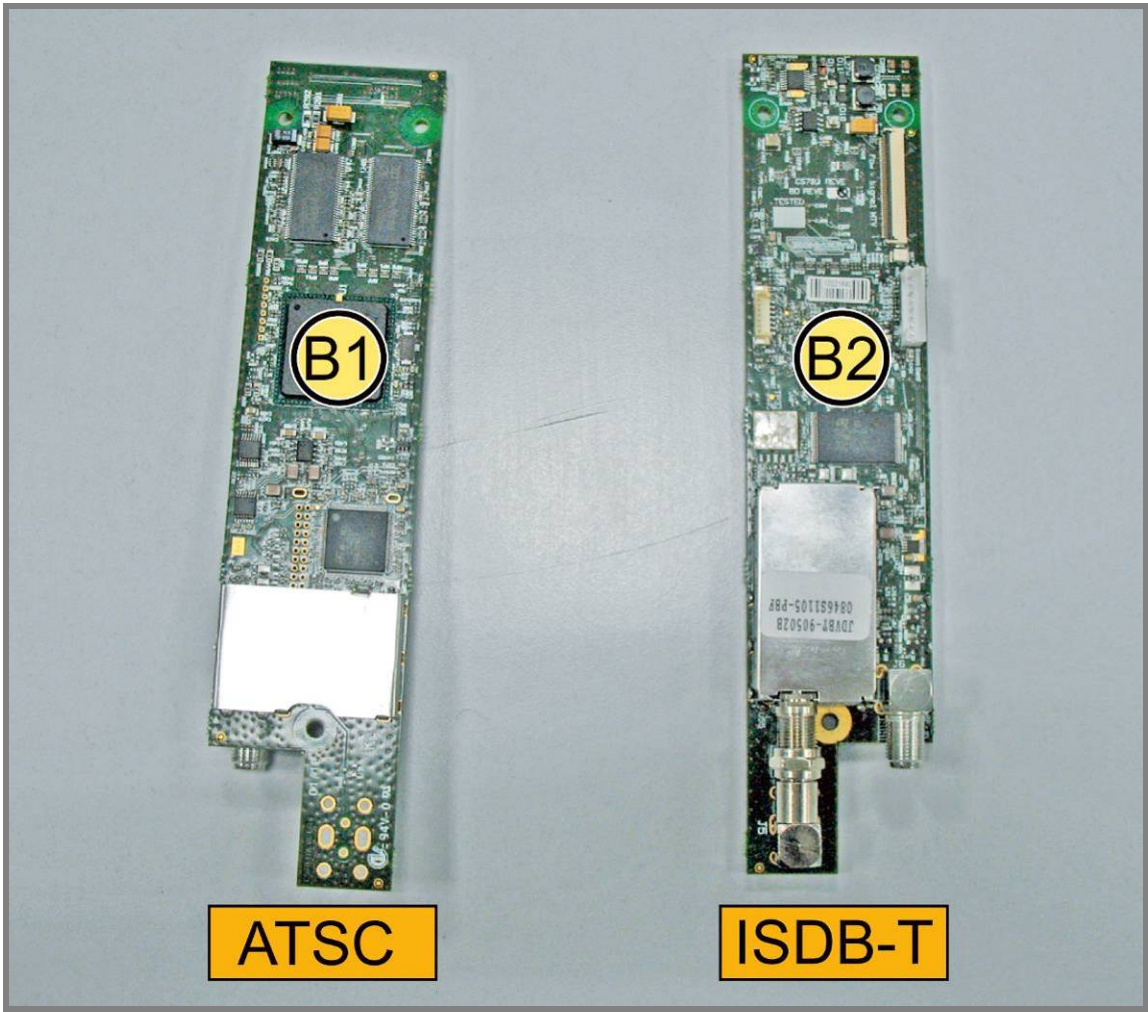


Figure 7.2-11

Carry out the procedure described in paragraph: 7.2.2.2 “Tuner DVB-T board (B)” at step (4).

1. Remove the Tuner board ver. ATSC (B1), or ver. ISDB-T (B2).

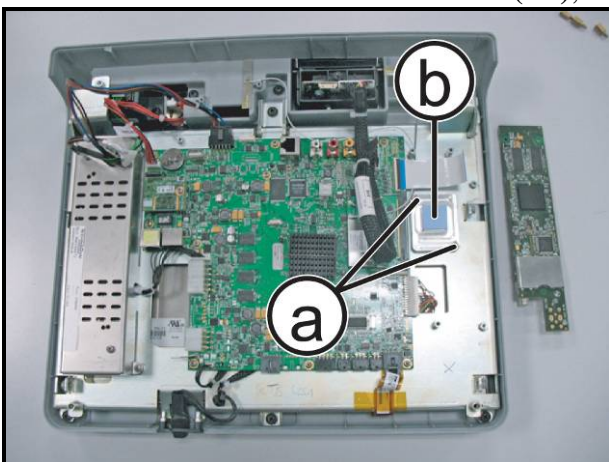


Figure 7.2-12

2. Back off the 2 screws (a), using a medium Phillips Screwdriver.
3. Remove the dissipater (b).

To reassemble the Tuner Boards, follows the above steps in the reverse order.

7.2.2.4. LCD Inverter (C)

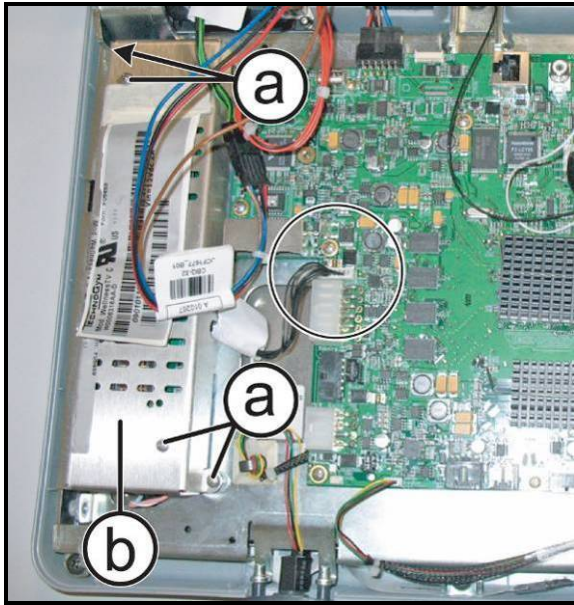


Figure 7.2-13



Figure 7.2-14

1. Unplug the connectors highlighted in the Figure.
2. Back off the 4 screws (a), using a medium Phillips Screwdriver.
3. Remove the LCD inverter cover (b).

4. Unplug the 4 connectors highlighted in figure.
5. Remove the LCD Inverter board (C).

To reassemble the Tuner Boards, follows the above steps in the reverse order.

7.2.2.5. CPU board (D)

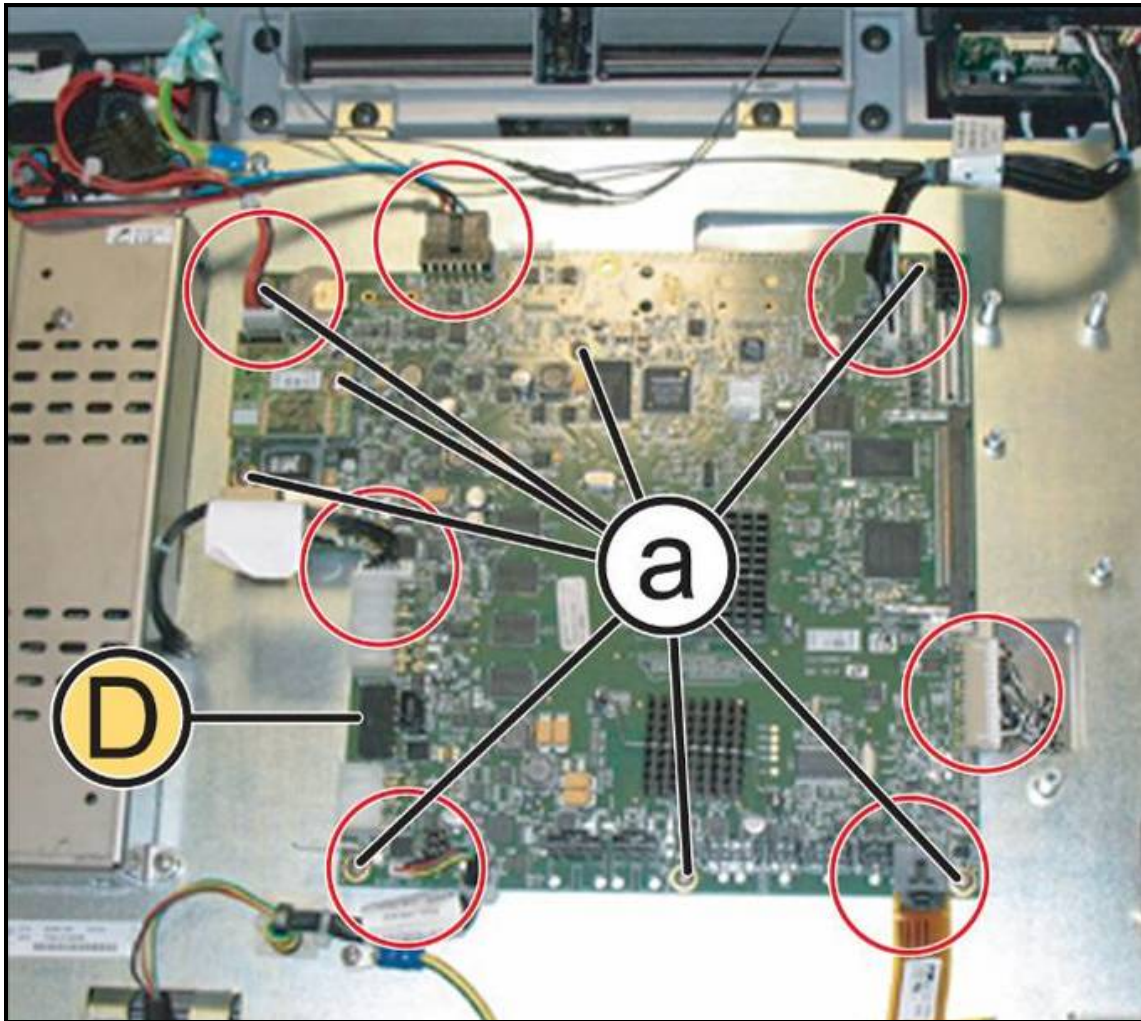


Figure 7.2-15

Carry out the procedure described in paragraph: 7.2.2.1 “Wireless board (A)” and 7.2.2.2 “Tuner DVB-T board (B)”.

1. Unplug the connectors highlighted in the figure.
2. Back off the 8 screws (**a**) using a medium Phillips Screwdriver.
3. Remove the CPU board (**D**).

*To reassemble the CPU Board,
follows the above steps in the reverse order.*

7.2.2.6. LCD (E) + Touch Screen

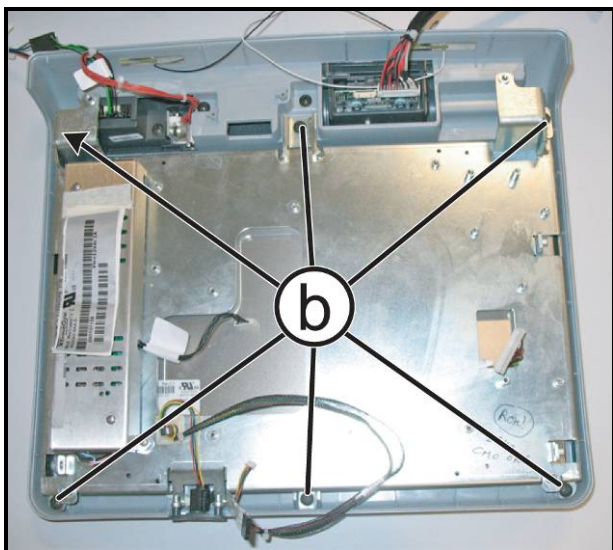


Figure 7.2-16



Figure 7.2-17

Carry out the procedure described in paragraph: 7.2.2.5 “CPU board (D)”.

1. Back off the 6 screws (**b**) using a medium Phillips Screwdriver.
2. Remove the LCD Inverter as described in the paragraph: 7.2.2.4 “LCD Inverter (C)”.
3. Remove the LCD group completely.
4. Carefully overturn the LCD group.
5. Back off the 2 screws (**c**) on the both side, using a medium Phillips Screwdriver.
6. Remove the LCD (**E**) from the support plate.

To reassemble the LCD and the Touch Screen, follows the above steps in the reverse order.

7.2.2.7. Headphone Jack (F)

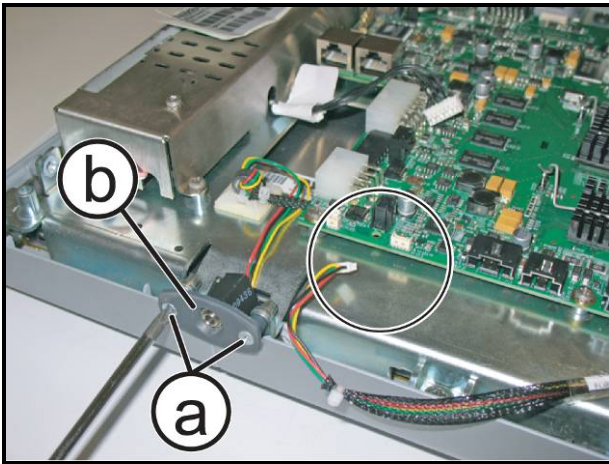


Figure 7.2-18

1. Unplug the connector highlighted in the figure.
2. Back off the 2 screws (a) using a small Phillips screwdriver.
3. Remove the Headphone Jack (F).

To reassemble the Headphone Jack, follows the above steps in the reverse order.

7.2.2.8. Dual TGS reader + USB port (G)

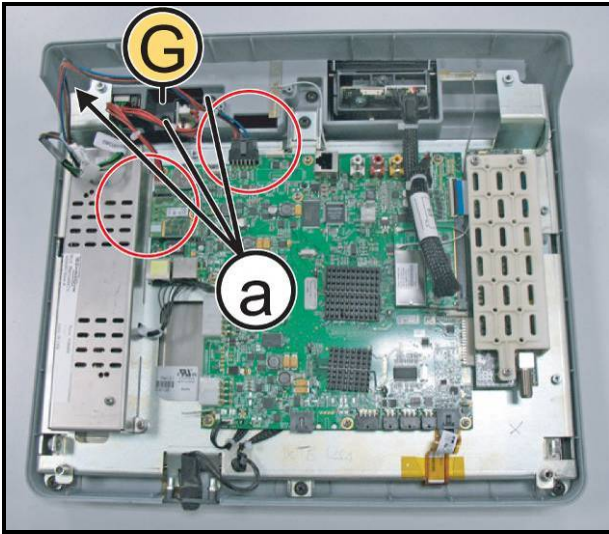


Figure 7.2-19

1. Unplug the cables highlighted in the figure.
2. Back off the 3 screws (**a**) using a medium Phillips Screwdriver.
3. Remove the TGS group and the USB port (**G**), as indicated in the figure at the side.

To reassemble the Dual TGS reader and the USB port, follows the above steps in the reverse order.

7.2.2.9. iPod Docking Station (H)

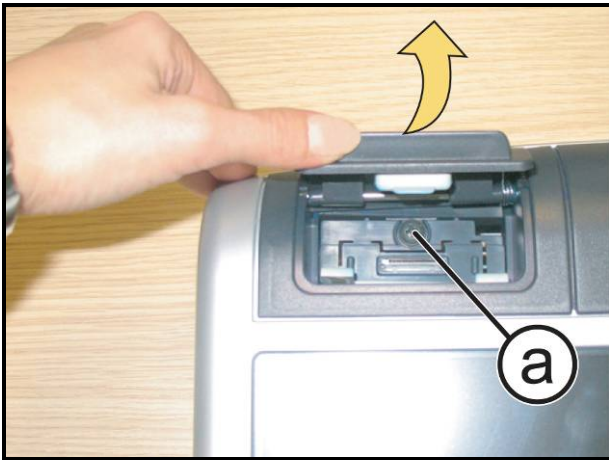


Figure 7.2-20

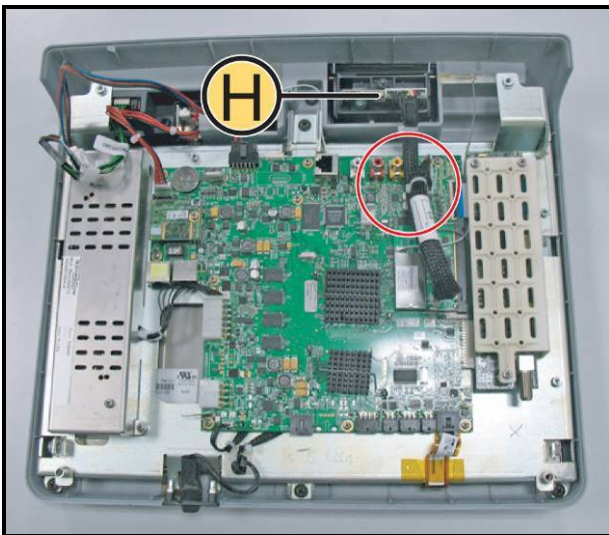


Figure 7.2-21

1. Lift the Docking Station covering cap up and back off the screw (a) using a medium Phillips screwdriver

2. Unplug the cable highlighted in the figure and remove the iPod Docking Station (H).

To reassemble the iPod Docking Station, follows the above steps in the reverse order.

7.2.2.10. Frontal plugs TGS + USB and cover

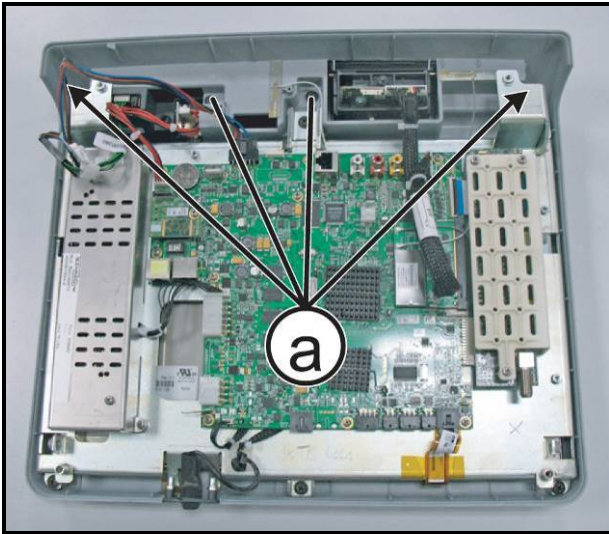


Figure 7.2-22

1. Back off the 4 screws (**a**) using a medium Phillips screwdriver.
2. Remove the frontal plug from the front side.

To reassemble the Frontal plugs and USB port, follows the above steps in the reverse order.

7.3. DISASSEMBLING THE KEYBOARD / TOUCH SCREEN

7.3.1. LED KEYBOARD

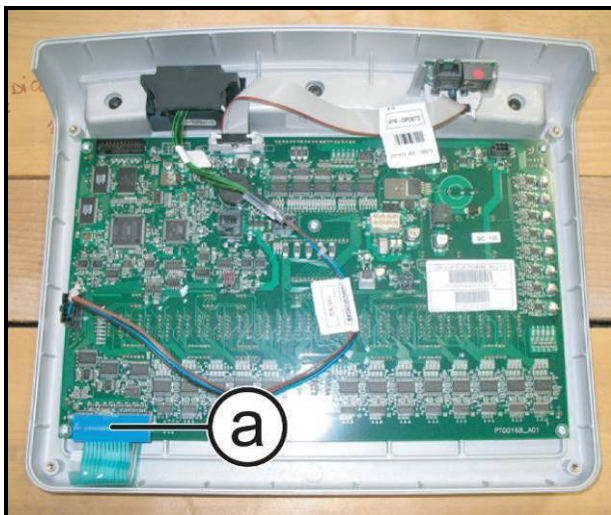


Figure 7.3-1

Carry out the procedure described in paragraph: 7.1. “Disassembling the display” to the point (3).

Place the display assembly on a work bench:

1. Unplug the connector (a).



After the reassembling of the board, remember to fix the keyboard connector using a drop of hot glue.

500 model



Figure 7.3-2

700 model



Figure 7.3-3

2. Use a sharp tool to lift up and detach a corner of the keyboard then remove the keyboard.

Continued on following page ...

To assemble a new keyboard:

1. Remove the backing film which protects the adhesive.
 2. Insert the connector in the special slot on the display and connect it to the ARM Board.
 3. Apply the adhesive part, starting from the left and working toward the right, without bending the keyboard.
 4. Remove the protective film.
-



The keyboard assembly procedure can only be carried out once, because disassembly damages the tracks and keys.



When reassembling the keyboard, make sure that none of the keys are bent or remain pushed in.



After the reassembly of the Display, check the proper functioning of new keyboard, as described at the paragraph: 6.1.4.1 “Man. Keyboard Test”.

7.3.2. VISIO VERSION

For the Touch Screen disassembly, refer to the Display Board disassembling procedure described at the paragraph: 7.2.2.6 “LCD (E) + Touch Screen”.

7.4. DISASSEMBLING THE CARDIO RECEIVER

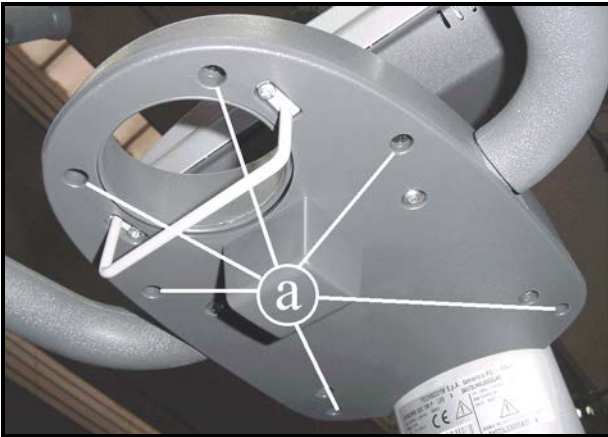


Figure 7.4-1

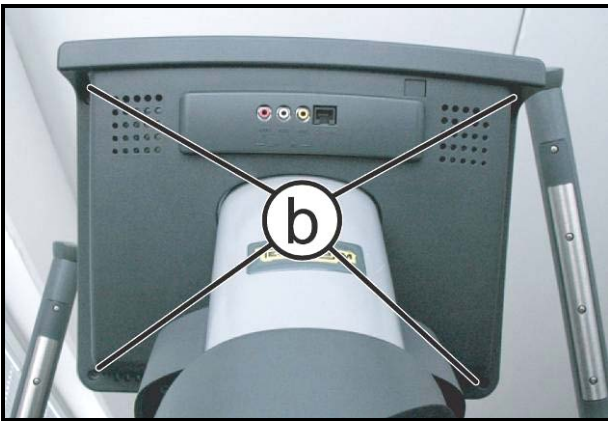


Figure 7.4-2

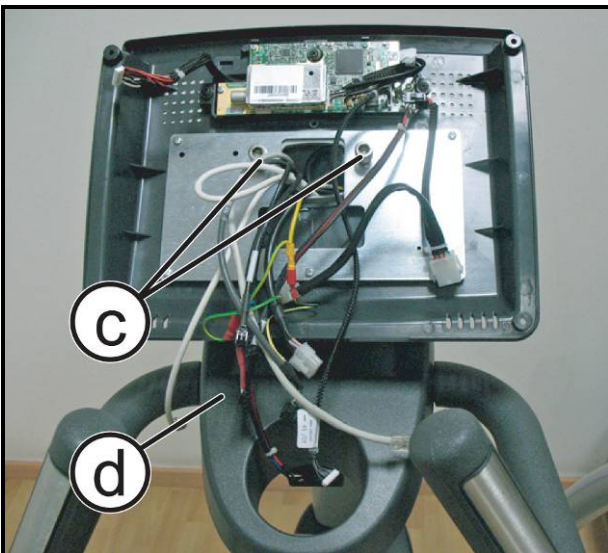


Figure 7.4-3

Turn off the machine and unplug the mains lead from the wall outlet.

1. Back off the 6 screws (a) using a medium Phillips screwdriver.
2. Back of the 4 screws (a) with a medium Phillip screwdriver.
3. Lift up and remove the display from the machine.
4. Loosen the 2 screws (c) using an 8mm hexagonal wrench.
5. Remove the upper cover (d).

Continued in following page...

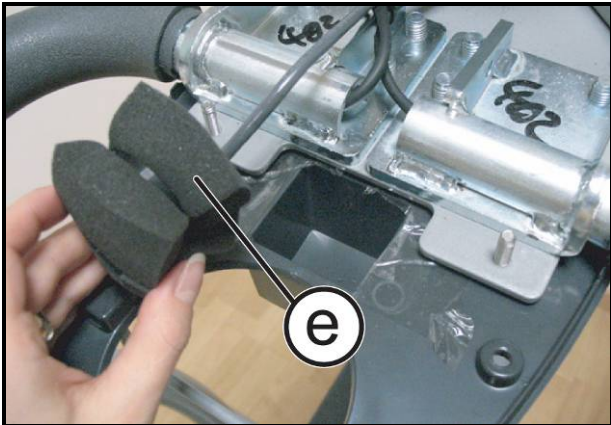


Figure 7.4-4

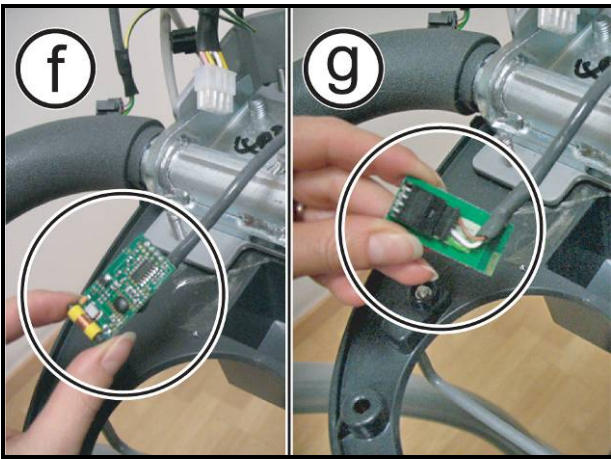


Figure 7.4-5

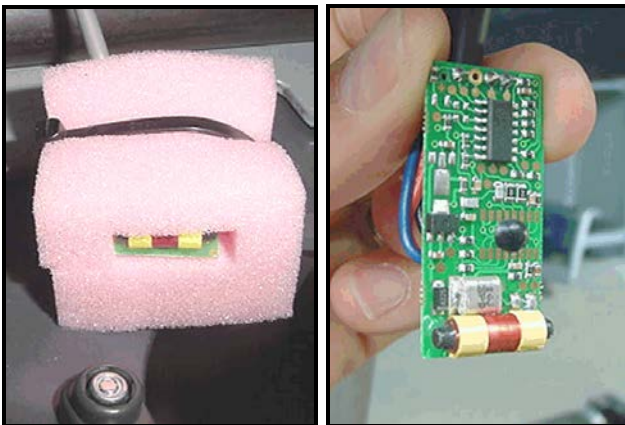


Figure 7.4-6

1. Remove the adhesive tape which keep the receiver in its housing.
6. Remove the cable tie and extract the cardio receiver from the protection sponge (e).

2. Extract the cardio receiver as shown in the figure (f) and disconnect the connector as shown in the figure (g).
7. Remove the receiver and replace if it is necessary.

3. Rewind the receiver in the sponge and rewind all in a cable tie for look all.

ATTENTION: Position the receiver so that the coil is oriented upward and towards the user, as shown in the figure at the side.

To reassemble the cardio receiver, carry out the above steps in reverse order.

7.5. DISASSEMBLING THE FIXED HANDGRIPS

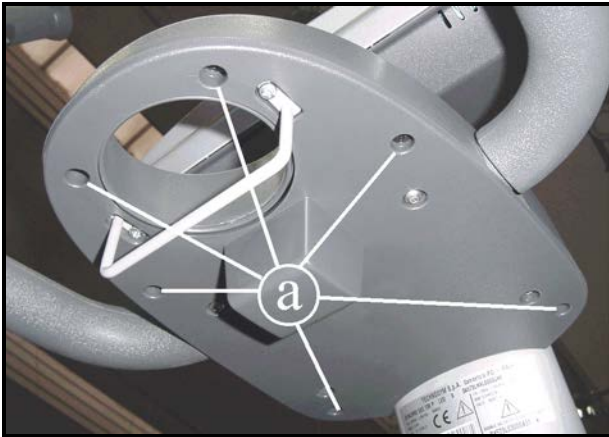


Figure 7.5-1

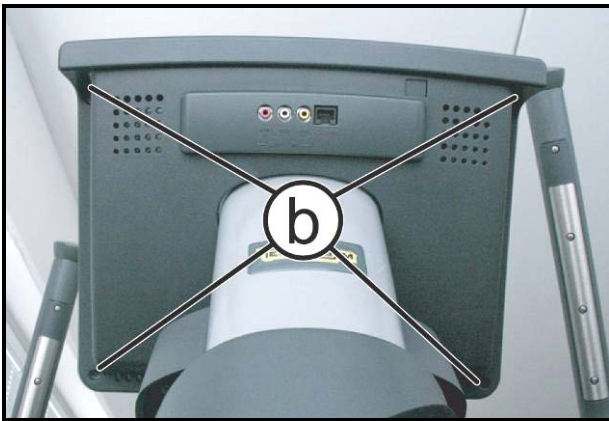


Figure 7.5-2

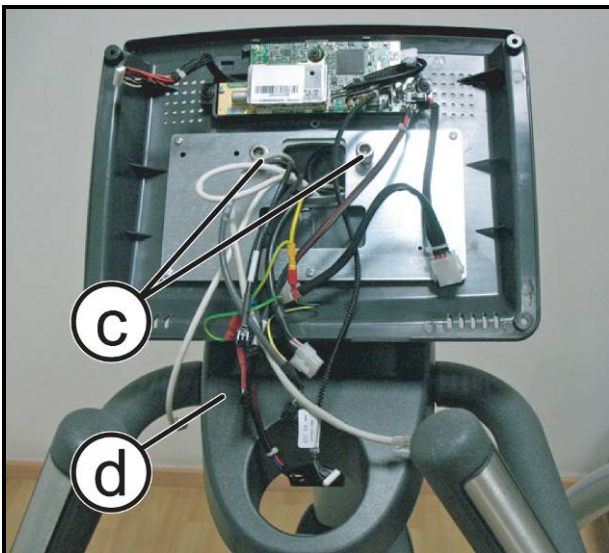


Figure 7.5-3

Turn off the machine and unplug the mains lead from the wall outlet.

1. Back off the 6 screws (a) with a medium Phillip screwdriver.
2. Back off the 4 screws (a) with a medium Phillips screwdriver.
3. Lift up the display.
4. Loosen the 2 screws (c) with a 8mm hexagonal wrench.
5. Remove the upper tray bracket (d).

Continued in following page...

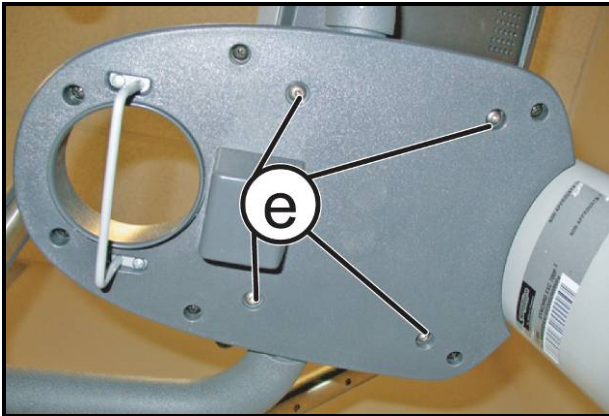


Figure 7.5-4

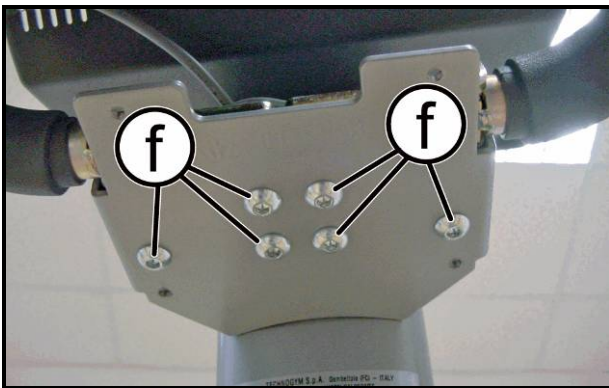


Figure 7.5-5

1. Back off the 4 screws (e) using a 4mm hexagonal wrench.

6. Remove the lower tray bracket.

2. Back off the 6 screws (f) with a 6mm hexagonal wrench (*back off the 3 at the right side or at the left side depending on the handlebar you want to remove*).

3. Remove the handgrips.



In case of a 700 machine, before disassembly the levers, disconnect the Hand Sensor cables leaving from upright, down when to come out.

To reassemble the handgrips, carry out the above steps in reverse order.

7.6. DISASSEMBLING THE HAND SENSOR



Only for powered version: 700, 700SP and 700VISIO.

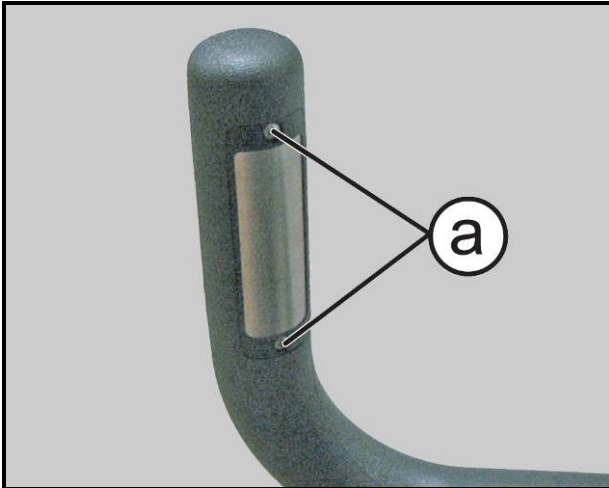


Figure 7.6-1



Figure 7.6-2

Turn off the machine and unplug the mains lead from the wall outlet.

For each handle sensor:

1. Back off the 2 screws (a) using a small Phillips screwdriver.
2. Lift up the top sensor.
3. Remove the lower sensor.
4. To disconnect the sensors, unplug the two Faston indicated in the figure.

Continued in following page...

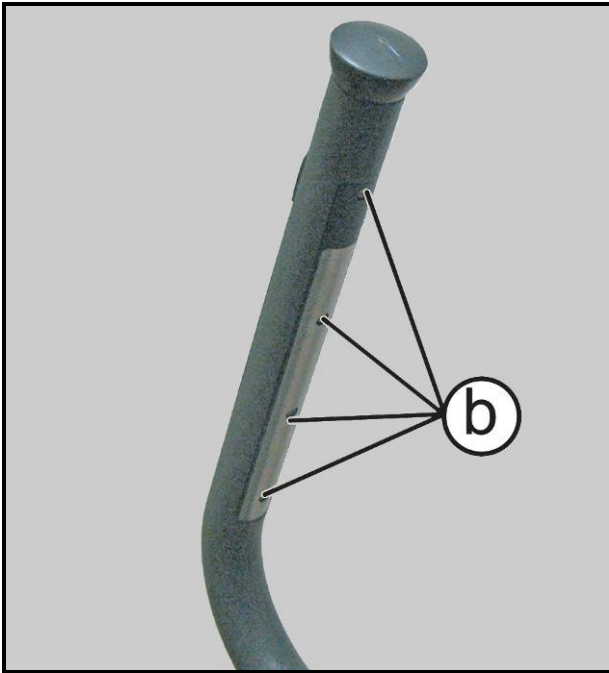


Figure 7.6-3



Figure 7.6-4

For each lever sensor:

1. Back off the 4 screws **(b)** using a small Phillips screwdriver.
2. Lift up the top sensor.
3. Remove the lower sensor.
4. To disconnect the sensors, unplug the two faston and the connector **(c)** of the touch sensor indicated in the figure.

To reassemble the sensors, carry out the above steps in reverse order.

7.7. DISASSEMBLING THE GUARDS

7.7.1. REAR GUARD

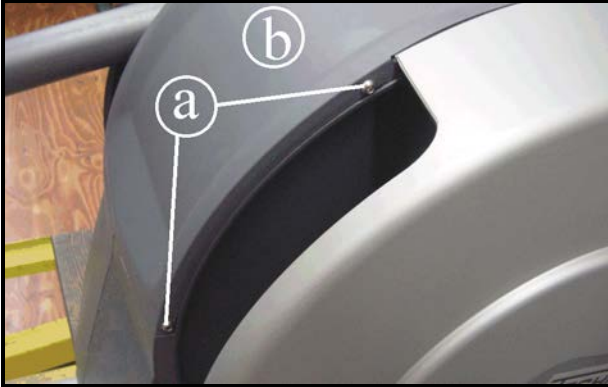


Figure 7.7-1



Figure 7.7-2

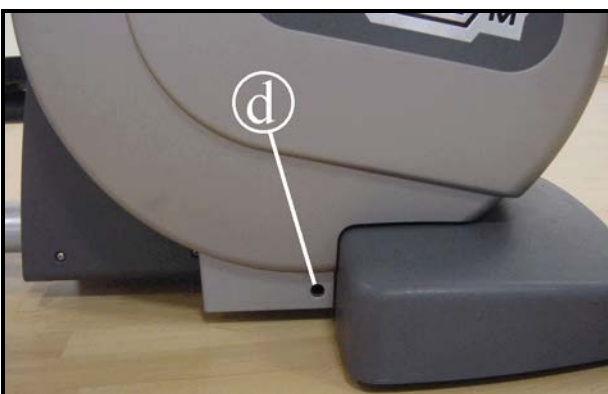


Figure 7.7-3

Turn off the machine and unplug the mains lead from the wall outlet.

1. Back off the screws (a), on both sides of the machine, using a 4mm hexagonal wrench.
2. Remove the top cover (b).
3. Back off the 4 screws (c) using an 8mm hexagonal wrench.
4. Back off the screw (d), on both sides of the machine, using a 4mm hexagonal wrench.
5. Remove the rear guard.

Continued in following page...

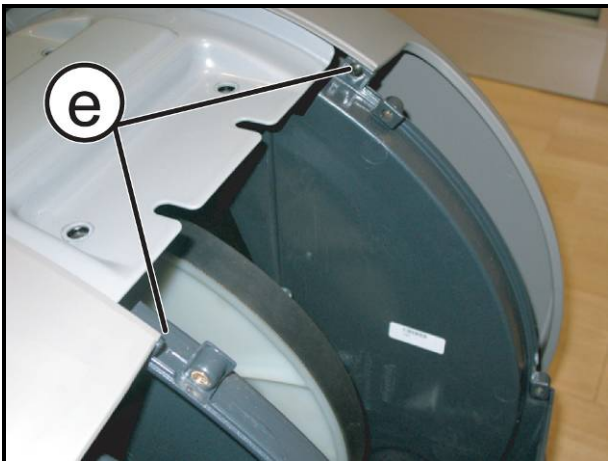


Figure 7.7-4

6. Back off the 2 screws (**e**), with a medium Phillips screwdriver

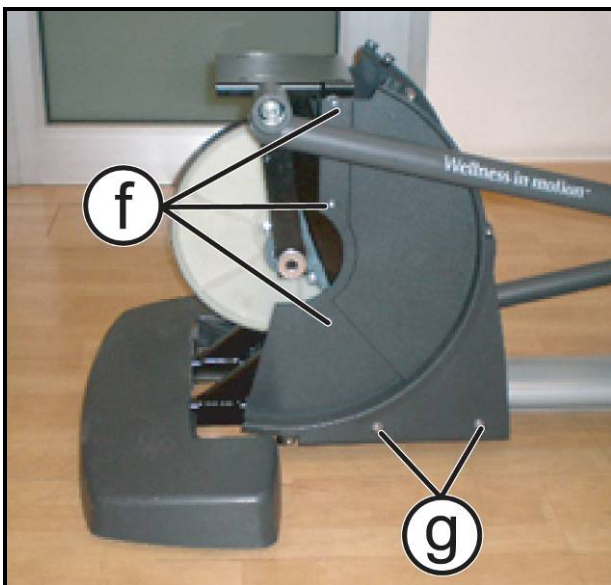


Figure 7.7-5

7. Back off the 3 screws (**f**), on both side of the machine, using a medium Phillip screwdriver
8. Back off the 2 screws (**g**), with a 4mm hexagonal wrench.
9. Remove the guard.

7.7.2. BRAKE BOX COVER GUARD

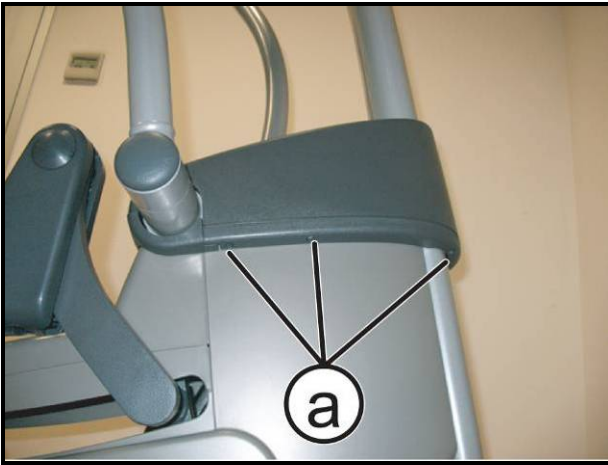


Figure 7.7-6

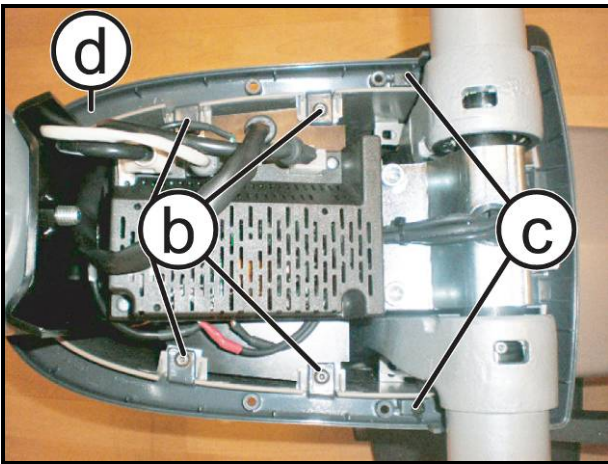


Figure 7.7-7

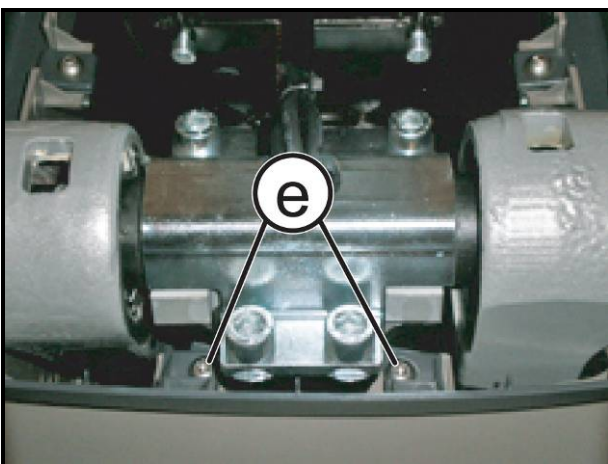


Figure 7.7-8

1. Back off the 3 screws **(a)**, on both sides of the machine, using a medium Phillips screwdriver.
2. Lift up the top cover along the display column and secure it with a strap.
3. Back off the 4 screws **(b)** with a 4mm hexagonal wrench.
4. Back off the 2 screws **(c)** with a medium Phillips screwdriver.
5. Remove the front casing **(d)**.
6. Back off the 2 screw **(e)**, with 4mm hexagonal wrench.
7. Remove the casing.

7.7.3. FRONT GUARDS

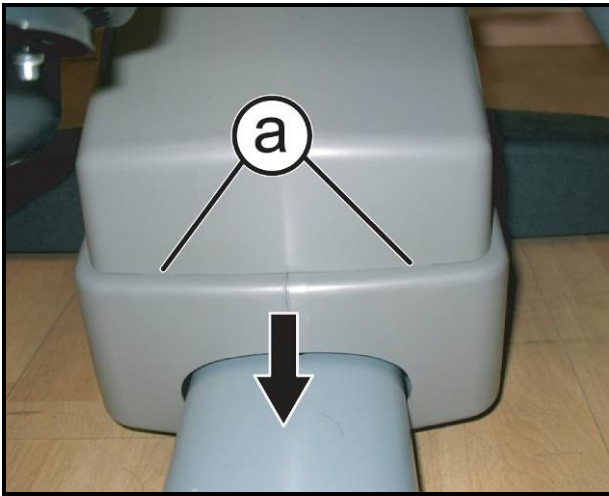


Figure 7.7-9

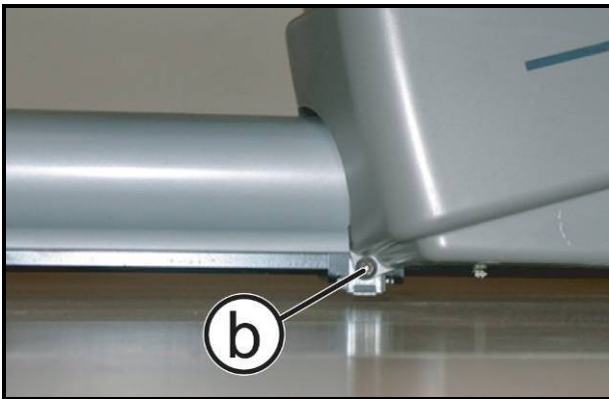


Figure 7.7-10

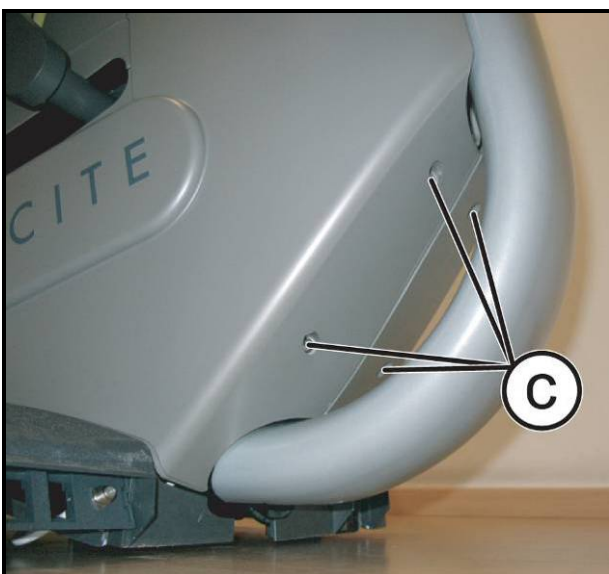


Figure 7.7-11

Carry out the operations described in paragraph: 7.7.2. "Brake box cover guard".

1. Remove the guard (a) unhook the tabs in the direction indicated by the arrows.
2. Pull it out from the top.
3. Back off the screws (b), on either side of the machine using a 4mm hexagonal wrench
4. Back off the 4 screws (c) using a 4mm hexagonal wrench m.
5. Remove the two lateral guards.

To reassemble the guards, carry out the above steps in reverse order.

7.8. DISASSEMBLING THE LEVERS

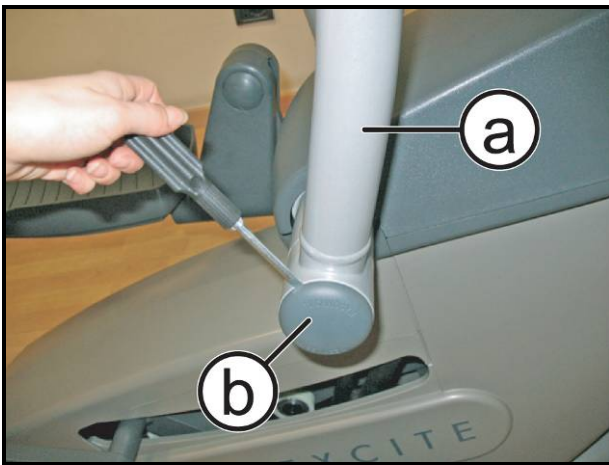


Figure 7.8-1

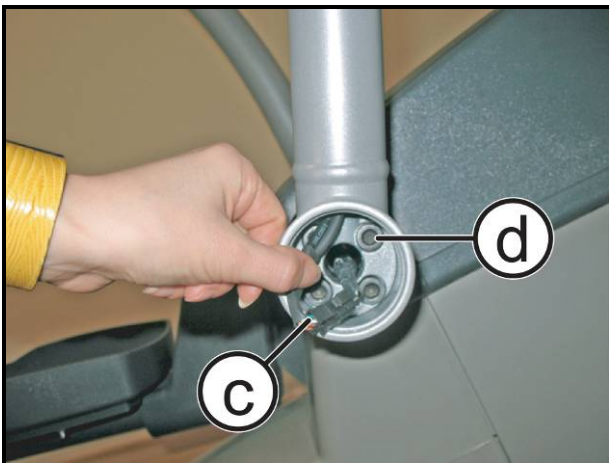


Figure 7.8-2

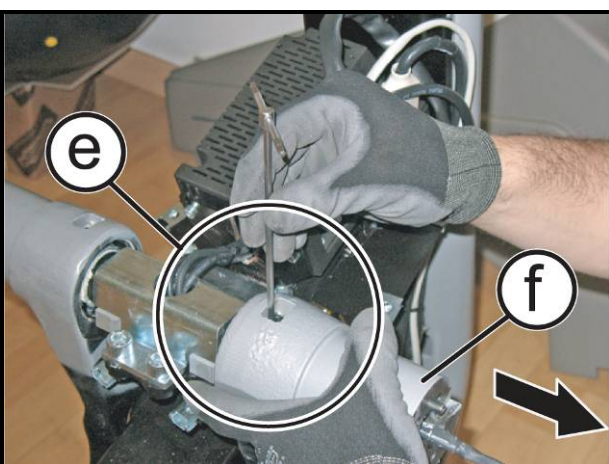


Figure 7.8-3

Turn off the machine and unplug the mains lead from the wall outlet.

1. To remove the lever (a), remove the plastic plug (b) forcing outwards with a small flat Phillips screwdriver.
2. Disconnect the connector (c).
3. Back off the 4 screws (d) with a 6mm hexagonal wrench.
4. Remove the lever from the machine frame.



ATTENTION: During reassembly, apply a drop of Loctite and lock down the screws (d) using a torque wrench setting of 37Nm.

Carry out the operations described in paragraphs: 7.7.2. "Brake box cover guard".

5. Back off the screw inside the housing (e), with a 3mm hexagonal wrench.
6. Remove the lever (f) from the frame, in the direction of arrow.

Continued in following page...

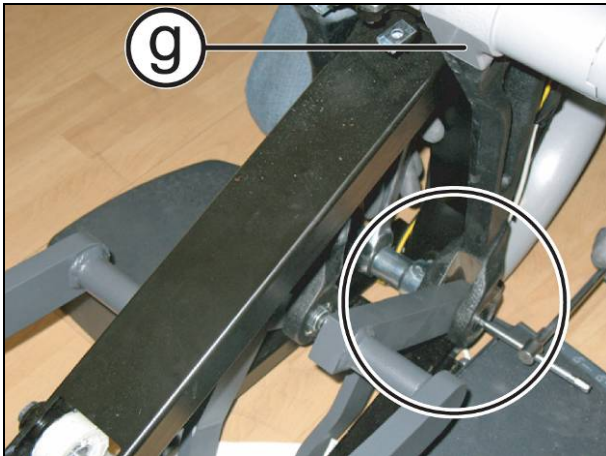


Figure 7.8-4



Figure 7.8-5

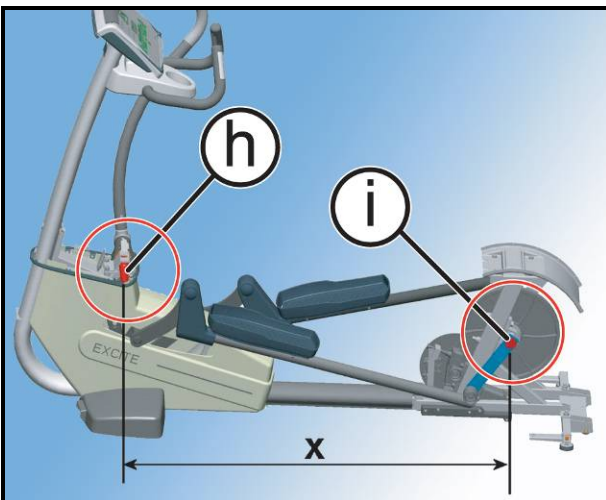


Figure 7.8-6

7. Remove the lever (g) since the constraint shown in Figure, using a 6mm hexagonal wrench and look the opposite ring nut with a 25mm ring nut spanner and a Ratchet wrench.

ATTENTION: During reassembly lock down the ring using a torque wrench setting of 44Nm.

The bearings are press assembled and lock with a Seeger

To reassemble the lever, carry out the above steps in reverse order.

CAUTION: In case is necessary to remove the pin (h): during the reassembly take care that the “X” measure, between the fulcrum of (h) and (i), is the same on the both side so to guaranty the lever parallelism.

7.9. DISASSEMBLING THE BRAKE BOX

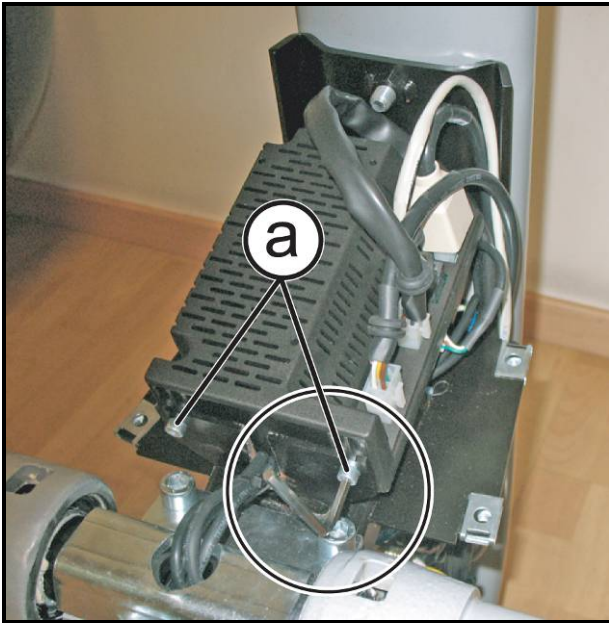


Figure 7.9-1



Figure 7.9-2

Carry out the operations described in paragraph: 7.7.2. "Brake box cover guard".

1. Back off the 2 screws **(a)**, with a 4mm hexagonal wrench.

2. Disconnect the 4 connectors highlighted in the figure at the side.

3. Replace the brake board if needed.

To reassemble the brake box, carry out the above steps in reverse order.

7.10. DISASSEMBLING THE HAND SENSOR



Only for powered version: 700, 700SP and 700VISIO.

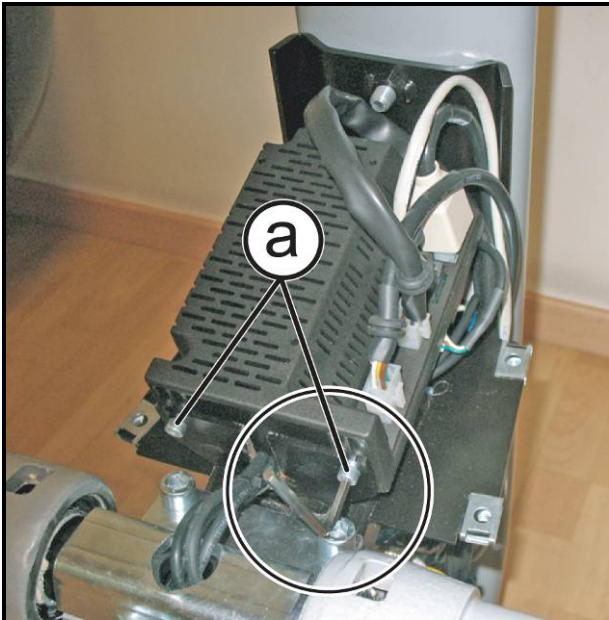


Figure 7.10-1

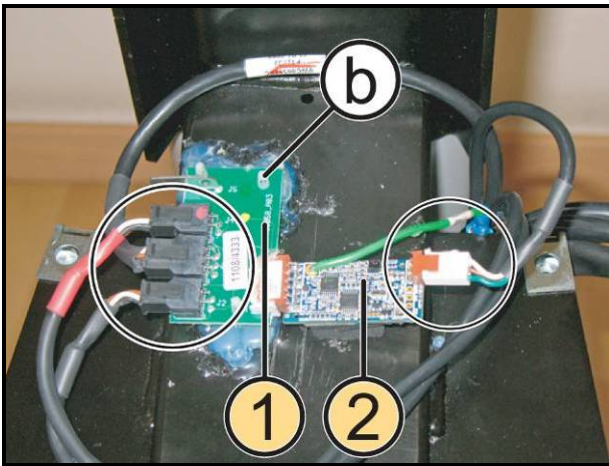


Figure 7.10-2

Carry out the operations described in paragraph: 7.7.2. “Brake box cover guard”.

1. Back off the 2 screws (**a**) that fixes the Brake Box at the frame, with a 3mm hexagonal wrench.
2. Remove the brake box.
3. Remove the board (**1**) and (**2**), through the plastic clip-sand (**b**) and/or remove the glue or the adhesive, replace if it's necessary.

To reassemble the hand sensor board, carry out the above steps in reverse order.

7.11. DISASSEMBLY THE PRIMARY SHAFT AND PULLEY

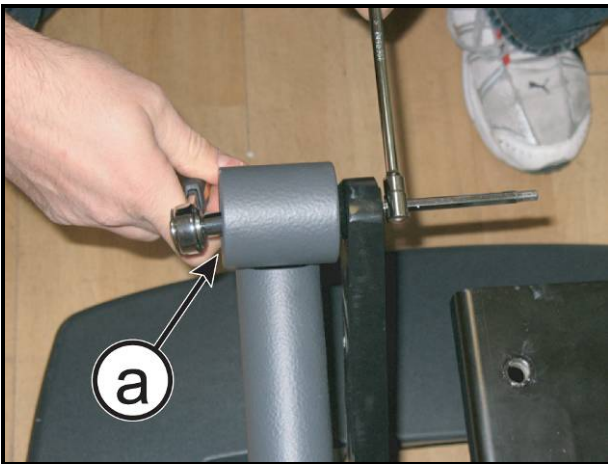


Figure 7.11-1

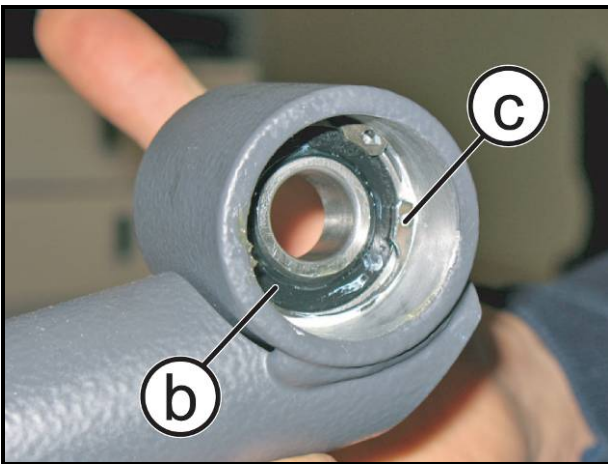


Figure 7.11-2

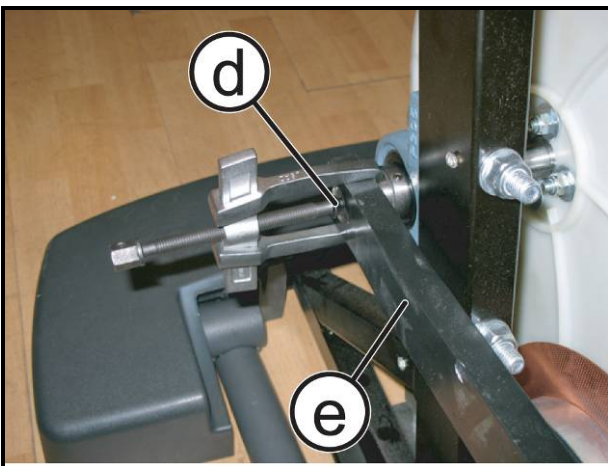


Figure 7.11-3

Carry out the operations described in paragraph: 7.7.1. "Rear guard".

For remove the pulley on both levers:

1. Back off the screw (a), with a 10mm hexagonal wrench, looking it on the opposite side.



ATTENTION: During reassembly, lock down the screws (a) using a torque wrench setting of 9Nm.

2. If necessary replace the bearing (b) removing the internal snap-ring (c).

3. Back off the screw (d) that locks the bars (e) with a small extractor, as shown in the figure at the side.

Continued in following page...

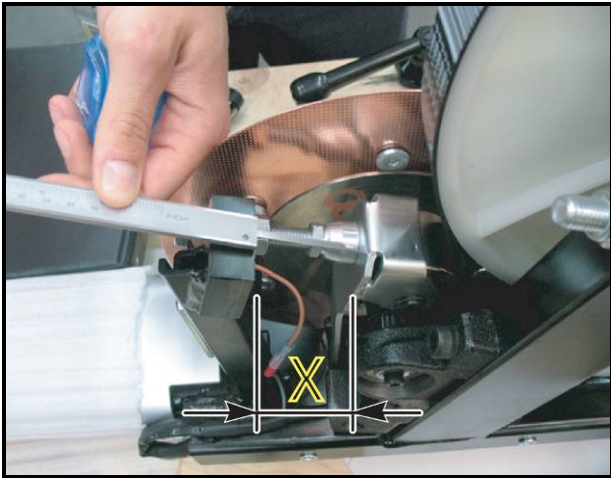


Figure 7.11-4



Take note about the measure “X” on the tighten device adjusting bolt.

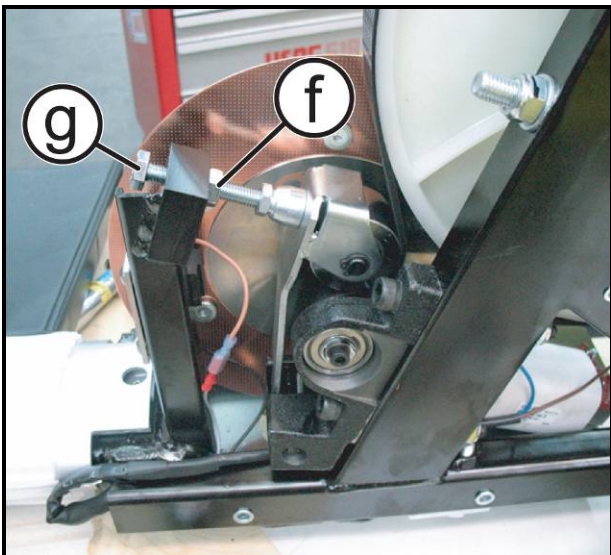


Figure 7.11-5

4. Loosen the nut (f) and the bolt (g), with a 17mm wrench; to loosen the tension on the belt.



Figure 7.11-6

5. Mark the position of the pillow blocks using a pen.
6. Unscrew the nut (h) using a 17mm wrench, locking the bolt on the opposite side, as shown in the figure at the side.



AVVERTENZA: If working on plastic support, pay attention to lock down the screws, using a torque wrench setting of 20Nm and no more.

Continued in following page...

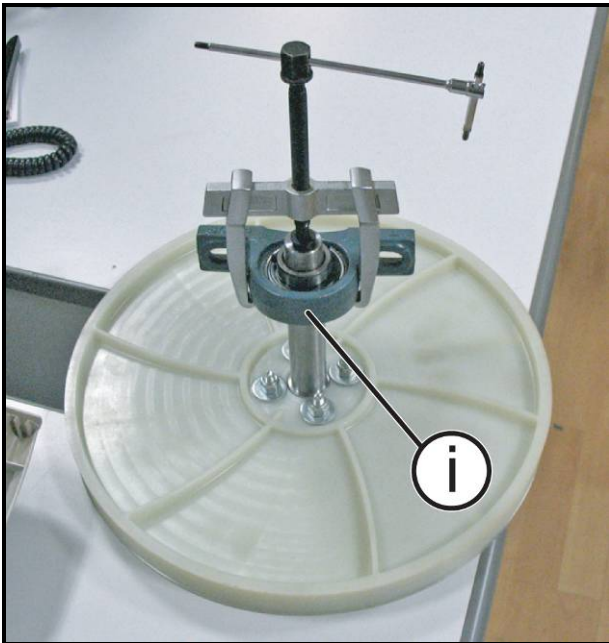


Figure 7.11-7

7. Use an extractor, to remove the axial support (i), as shown in the figure at the side.

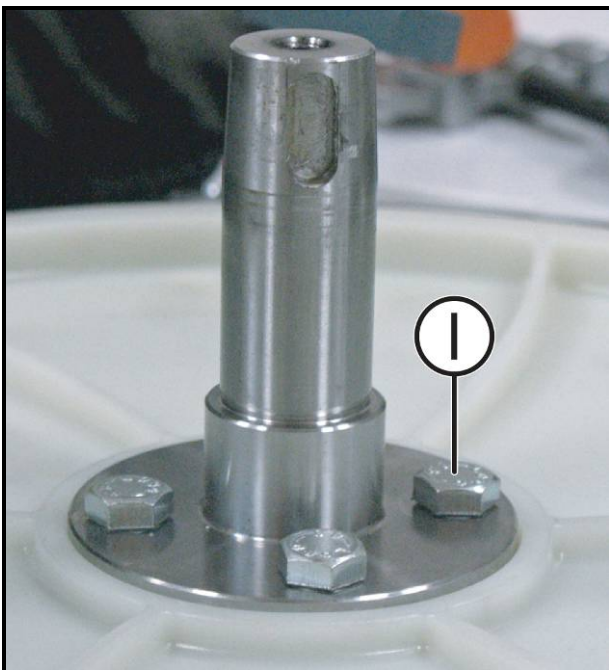


Figure 7.11-8

8. Back off the 4 screws (l) with a 13mm wrench, looking the nut on the opposite side. If necessary replace the primary shaft or the pulley.

To reassemble the group, carry out the above steps in reverse order, taking care of the following notes.

Continued in following page...

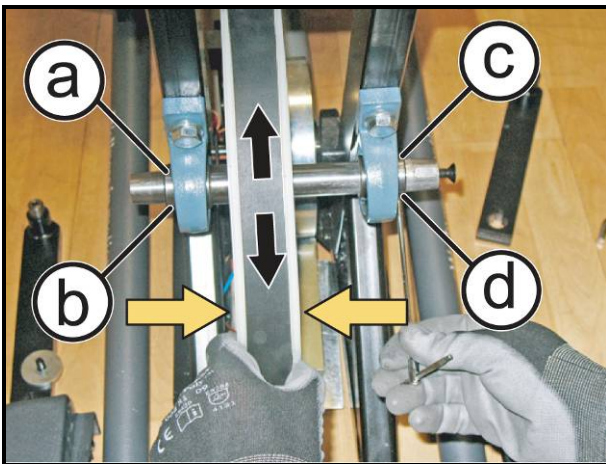


Figure 7.11-9



Reassembly notes:

1. Reinsert the belt on the pulley.
2. Place the 2 pillow blocks again on the shaft.
3. Lock the left pillow block on the machine frame.
4. Push the left pillow block up against the shaft ledge and tighten the grub screws (a) and (b).
5. Lock the right pillow block on the machine frame, so that the shaft is horizontal.
6. Rotate the pulley as indicated by the arrows, to align the right grub screws (c) and (d) with the left ones.
7. Tighten the right grub screws.



ATTENTION: Screw the grub screws indicated in the picture by the arrows, which are fixing the bearings, keeping them aligned on both the sides of the shaft.

8. Place the belt on the pulley, leaving one race free on the right side and one free on the left side, as indicated by the yellow arrows in the figure at the side.

Continued in following page...

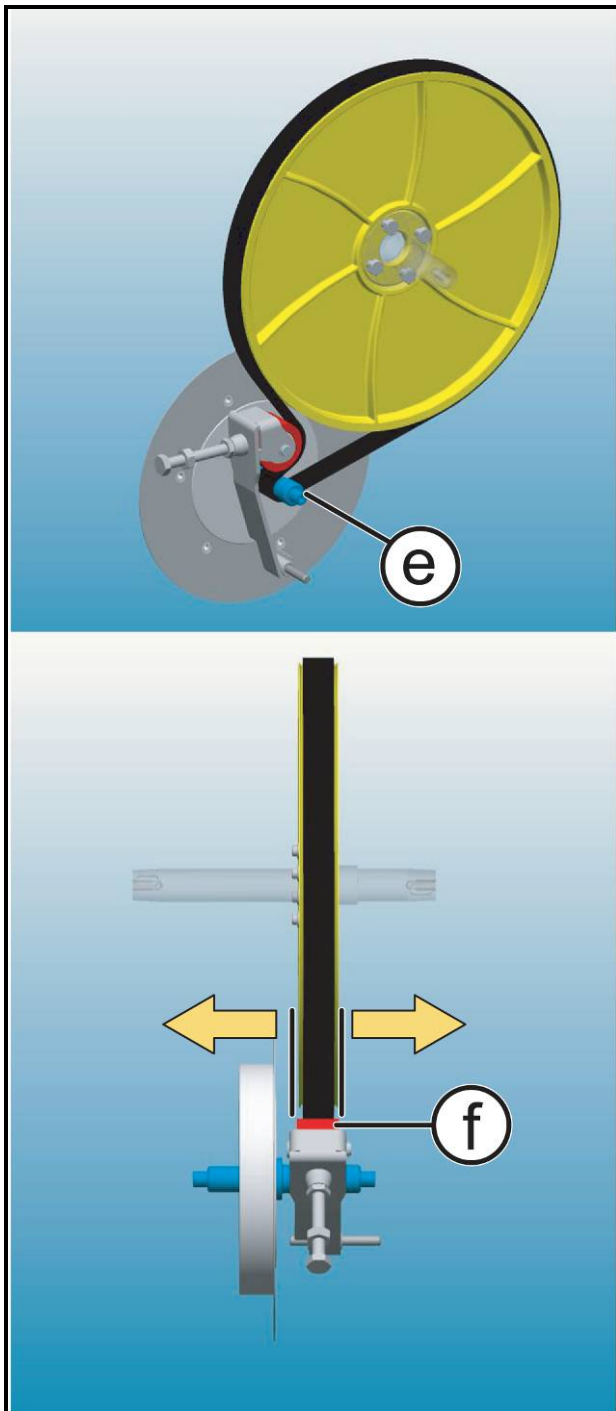


Figure 7.11-10

9. Place the belt on the pinion (e), so that the belt is as much aligned as possible with the pulley.
10. Tighten a little bit the belt and rotate the pulley until the belt is routing steadily on the pinion races.
11. Once stabilized the position of the belt, check that it works completely on the tighten device wheel (f) during the rotation



CAUTION: In case of the belt, during **THE** rotation, **DOES NOT** work completely on the tighten device wheel: repeat the above operations **shifting the belt of one race.**



To reassemble the same belt: tighten again referring to the marks previously done (see at the: Figure 7.11-4).



To assemble a new belt: refer to the paragraph: 8.1. "Belt tension".

7.12. DISASSEMBLING THE PLATFORM LEVER

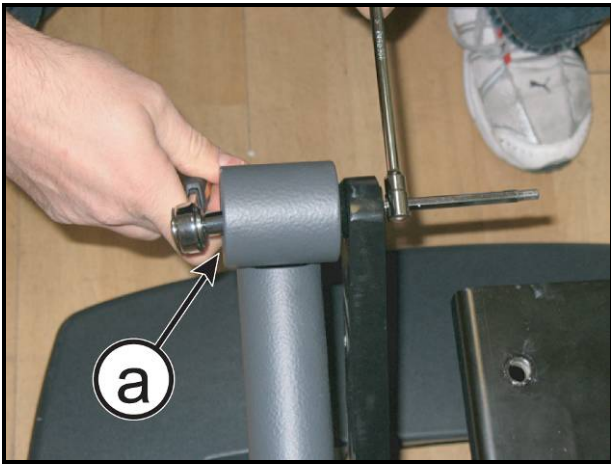


Figure 7.12-1

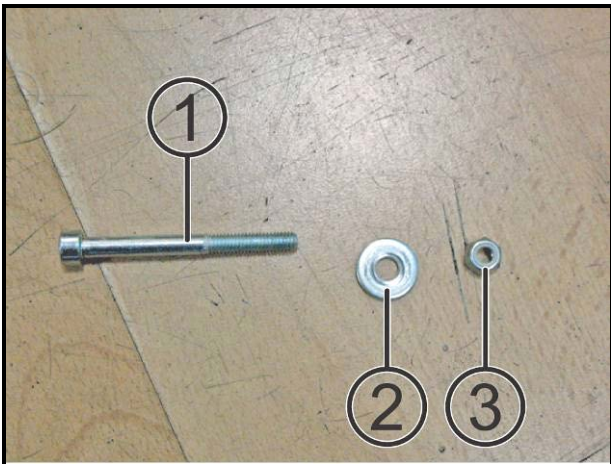


Figure 7.12-2

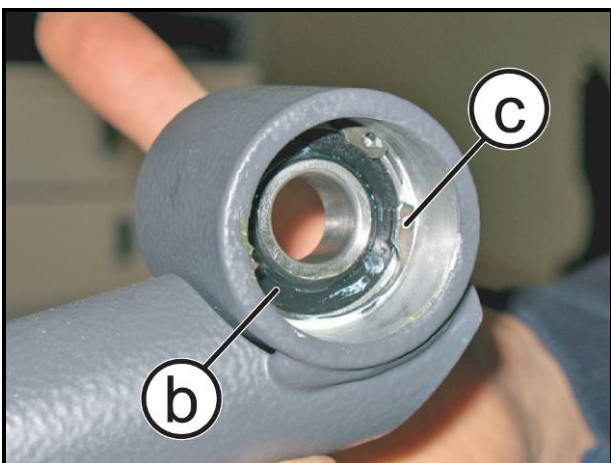


Figure 7.12-3

Carry out the operations described in paragraph: 7.7. "Disassembling the guards".

1. Back off the screw (a), with a 10mm hexagonal wrench, locking it on the opposite side.

⚠ During the reassembly insert first the bolt (1) and on the opposite side the washer (2) and the nut (3).

2. If necessary, replace the bearing (b): removing the internal snap-ring (c).

Continued in following page...

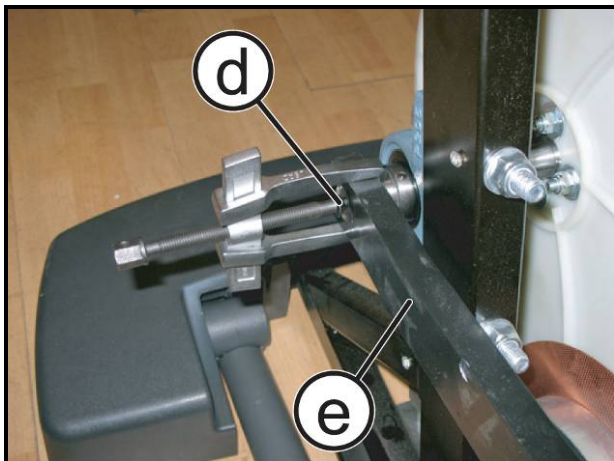


Figure 7.12-4

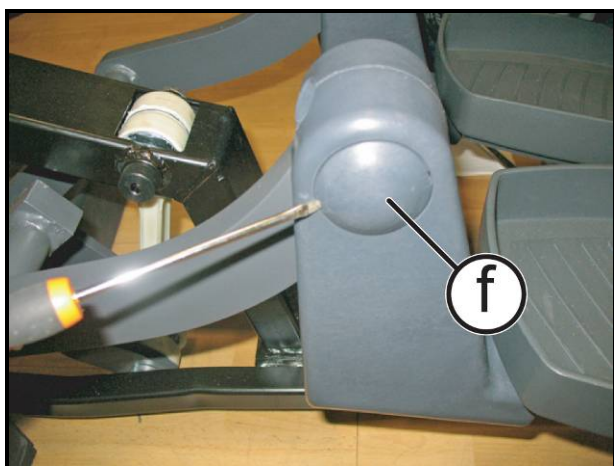


Figure 7.12-5

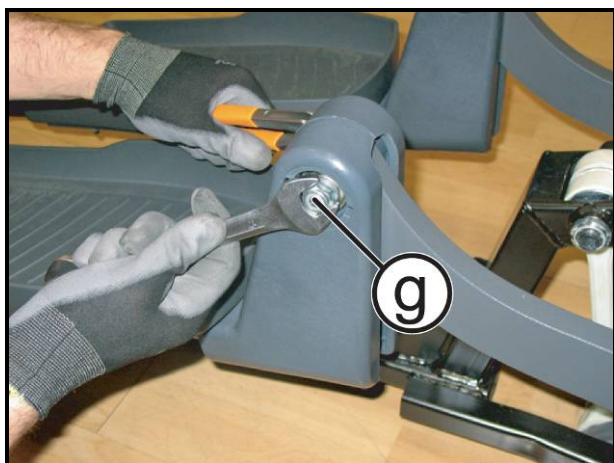


Figure 7.12-6

3. Remove the screw (d) that is locking the bar (e) with a medium extractor, as shown in the figure at the side.

Carry out the operations described in paragraph: 7.7.3. "Front guard".

4. Remove the plug (f) using a small flat Phillip screwdriver, on both the sides.

5. Back off the nut (g) using a 17mm wrench, locking the bolt on the opposite side with the same wrench, as shown in the figure.



ATTENTION: During reassembly lock down the nut using a torque wrench setting of 40Nm.

Continued in following page...

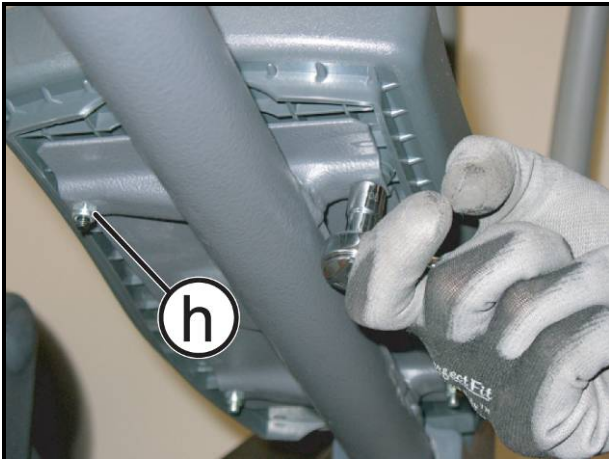


Figure 7.12-7

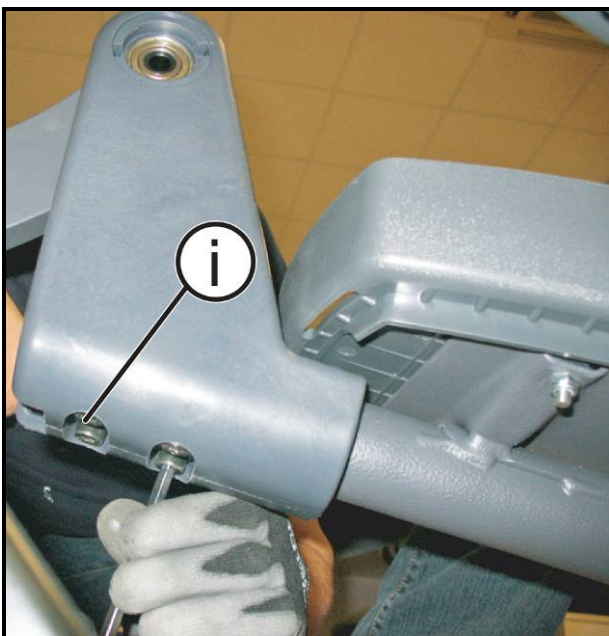


Figure 7.12-8



Figure 7.12-9

6. Back off the 4 nut (**h**) with a 10mm socket wrench.

7. Remove the footboard.

8. Back off the 4 screws (**i**) with a 4mm hexagonal wrench.



ATTENTION: During reassembly lock down the screws using a torque wrench setting of 15Nm, (not overly so as not to damage the plastic).

9. At this point it's possible to release the footboard lever from the front connection mechanism.

Continued in following page...

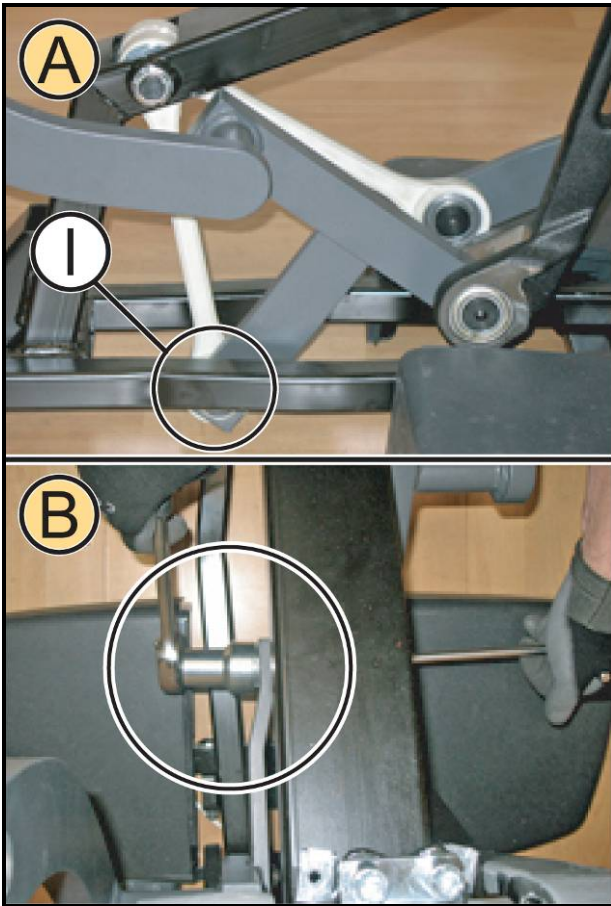


Figure 7.12-10

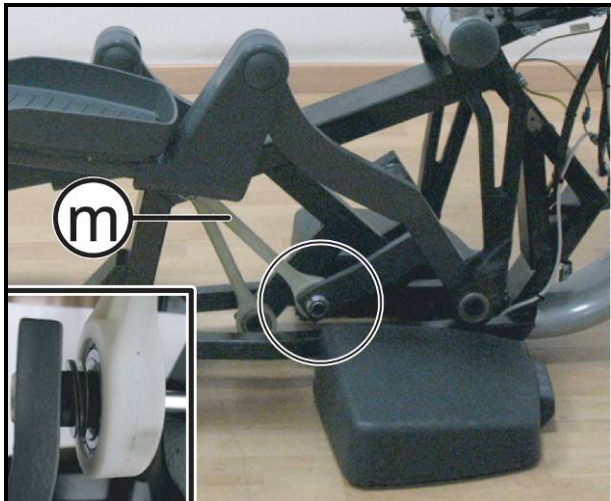


Figure 7.12-11

10. Remove the pin (I) indicate in the figure (A) with a 6mm hexagonal wrench and lock the ring nut on the opposite side with a 20mm ring nut spanner, as highlight in figure (B).



ATTENTION: During reassembly lock down the ring nut using a torque wrench setting of 62Nm.

11. Release the front lever (m).



During the reassembly place the 3 washer on the lever side and 1 washer on the internal side, as shown in the detail.

Continued in following page...

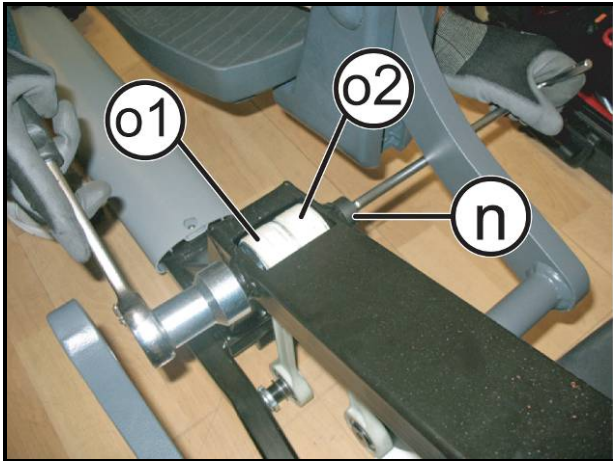


Figure 7.12-12

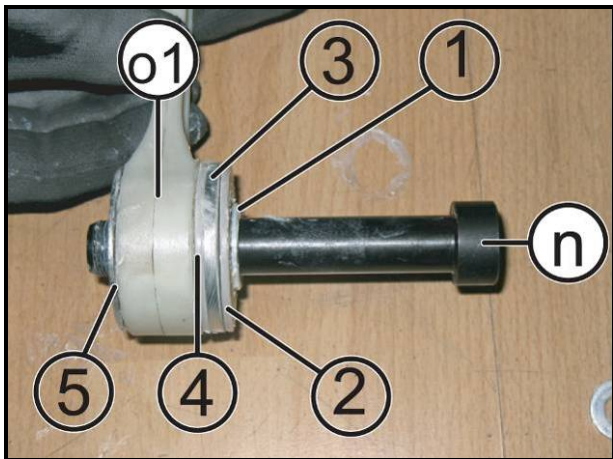


Figure 7.12-13

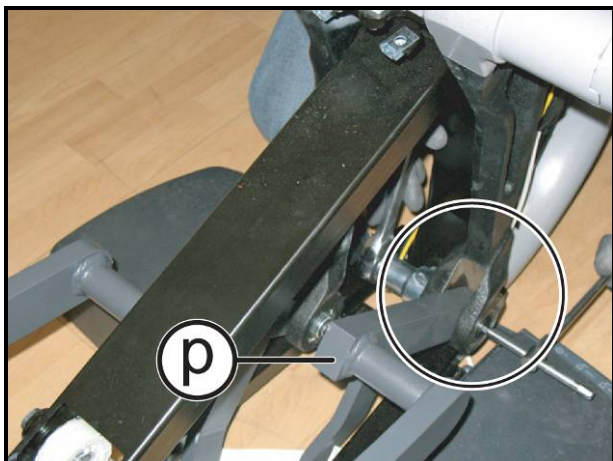


Figure 7.12-14

12. Back off the pin (**n**) with a 6mm hexagonal wrench, locking the ring nut on the opposite side using a 25mm ring nut spanner.
13. Remove the central lever (**o1**) and/or (**o2**) to replace, taking centred, in position, the other lever.



CAUTION: During reassembly lock down the ring nut using a torque wrench setting of 50Nm.



During the reassembly: respect the sequence at the side of spacers and washers, when remount again the two levers (**o1**) and (**o2**).



Place some grease on the levers shaft, before reassembly.

14. Release the lever (**p**) from the pin highlight in figure, using a 6mm hexagonal wrench and locking it the opposite ring nut with a 25mm ring nut spanner.
15. At this point is possible to remove the lever (**p**) from the frame.

7.13. DISASSEMBLING THE BRAKE WINDING

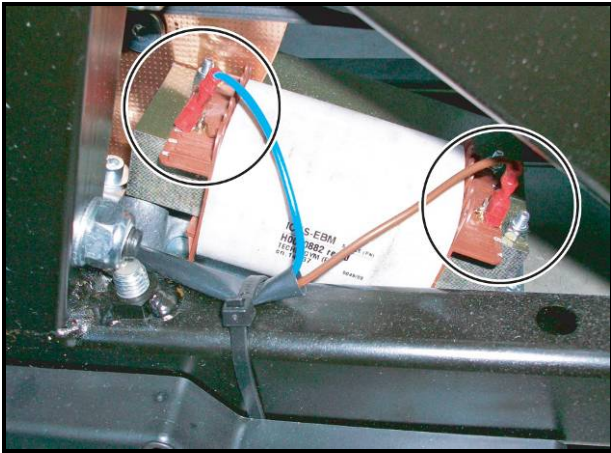


Figure 7.13-1

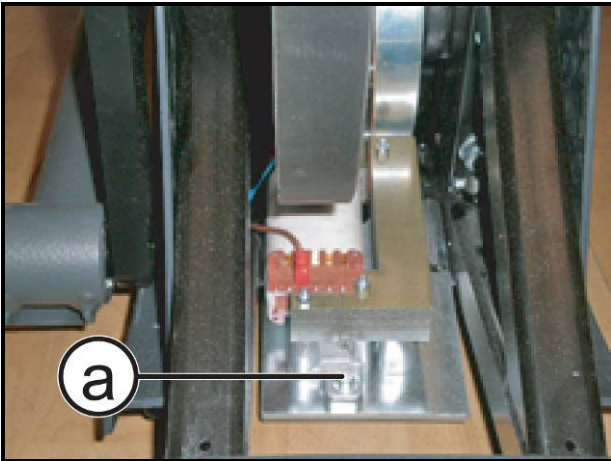


Figure 7.13-2

Carry out the operations described in paragraph: 7.7.1. "Rear guard".

1. Disconnect the 2 Faston highlighted in the figure.
2. Back off the screw (a) with a 4mm hexagonal wrench, on both sides.
3. Remove the brake winding from the bottom and replace if necessary.

To reassemble the brake winding, carry out the above steps in reverse order.



After completing the reassembly, carry out the adjustment procedure described in paragraph: 8.3. "Brake winding positioning".

7.14. DISASSEMBLING THE FLYWHEEL AND BETL TENSIONER

7.14.1. POWERED MODELS



Only for powered models: 500, 700 and 700VISIO.

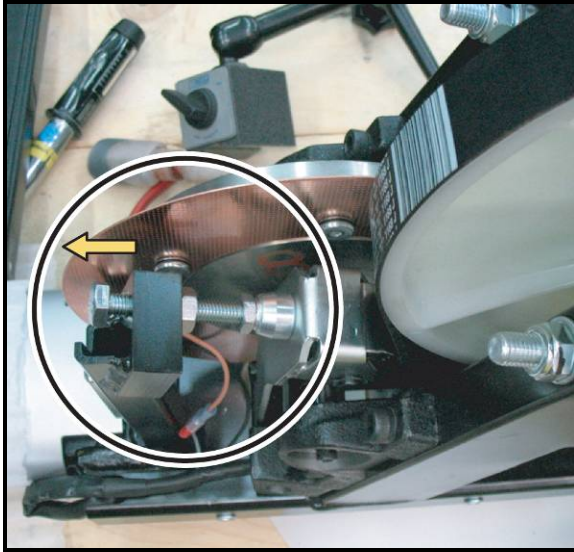


Figure 7.14-1

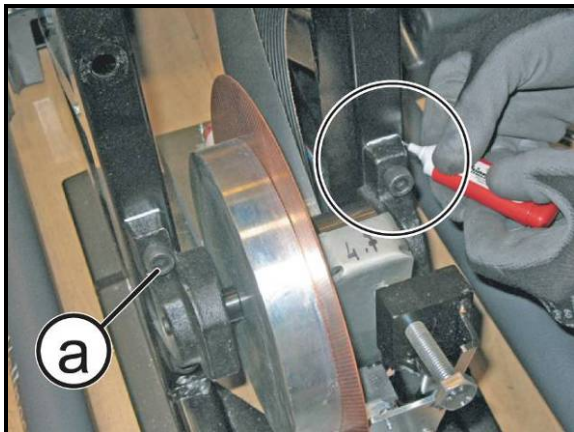


Figure 7.14-2

Carry out the operations described in paragraph: 7.7.1. "Rear guard".

1. Loosen the transmission belt, with a 17mm wrench, as highlighted in the figure.
2. Mark the position of pillow blocks, as shown in the figure.
3. Back off the 4 screws (a) that supports the flywheel, with an 8mm hexagonal wrench, locking the nut on the opposite side.

Continued in following page...

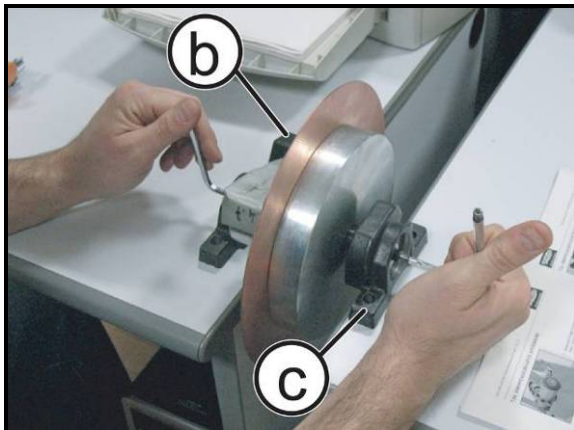


Figure 7.14-3

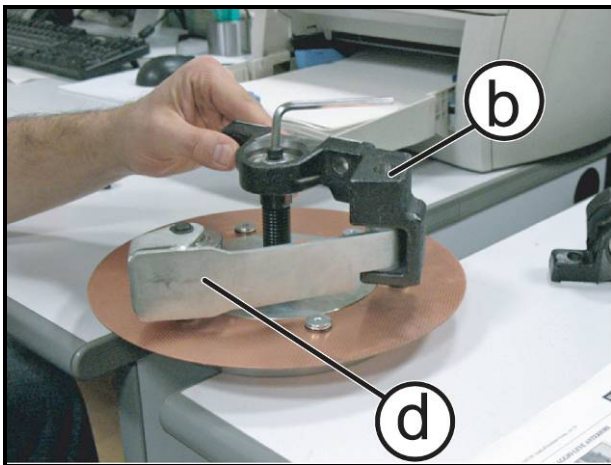


Figure 7.14-4

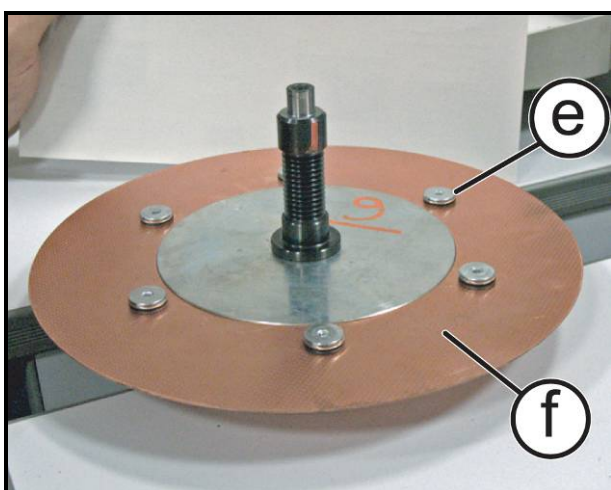


Figure 7.14-5

Bring the flywheel group on a work bench:

4. Remove the 2 pillow blocks (b) and (c) using two 5mm hexagonal wrenches, one against the other.
5. Remove the 2 pillow blocks.



CAUTION: During reassembly lock down the shaft screws, using a torque wrench setting of 10Nm and using the **LOCTITE 243**.

6. Unthread the pillow blocks belt tension system (b).
7. Replace the tension system belt (d) if necessary.
8. Back off the 6 screws (e) with a 4mm hexagonal wrench.
9. Replace the copper disk (f), if necessary.



CAUTION: During reassembly, lock down the screws (e) using a torque wrench setting of 6Nm.

To reassemble the flywheel group, carry out the above steps in reverse order.



WARNING: Take particular care with the copper disk, since it can bend easily.

7.14.2. SELF-POWERED MODELS



Only for Self-powered models: 500SP and 700SP.

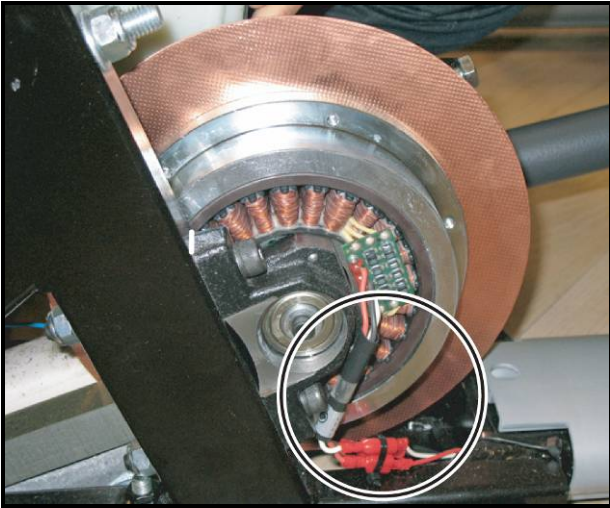


Figure 7.14-6

In order to bring the flywheel group on a workbench, carry out the operations described in paragraph: 7.14.1. “Powered models” disconnecting the 3 Faston highlight in the figure.

Bring the flywheel group on a work bench, as for the powered version:

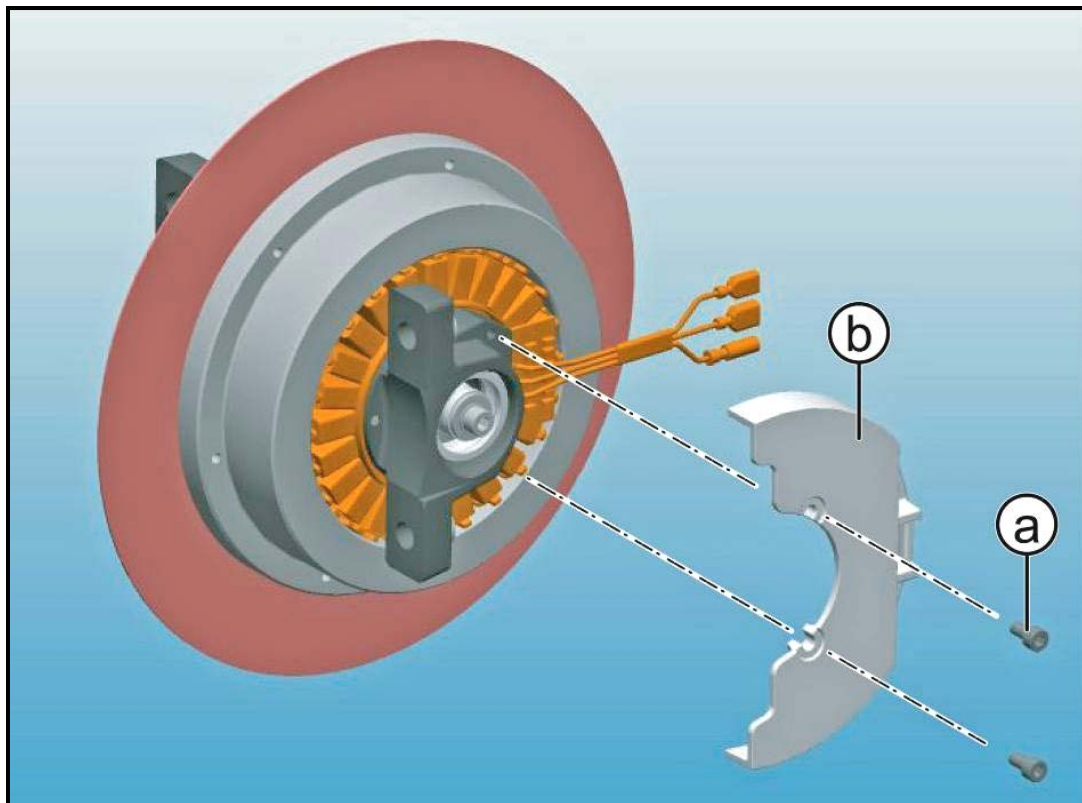


Figure 7.14-7

1. Back off the 2 screws (a) with a 4mm hexagonal wrench.
2. Remove the covering plate (b).

Continued in following page...

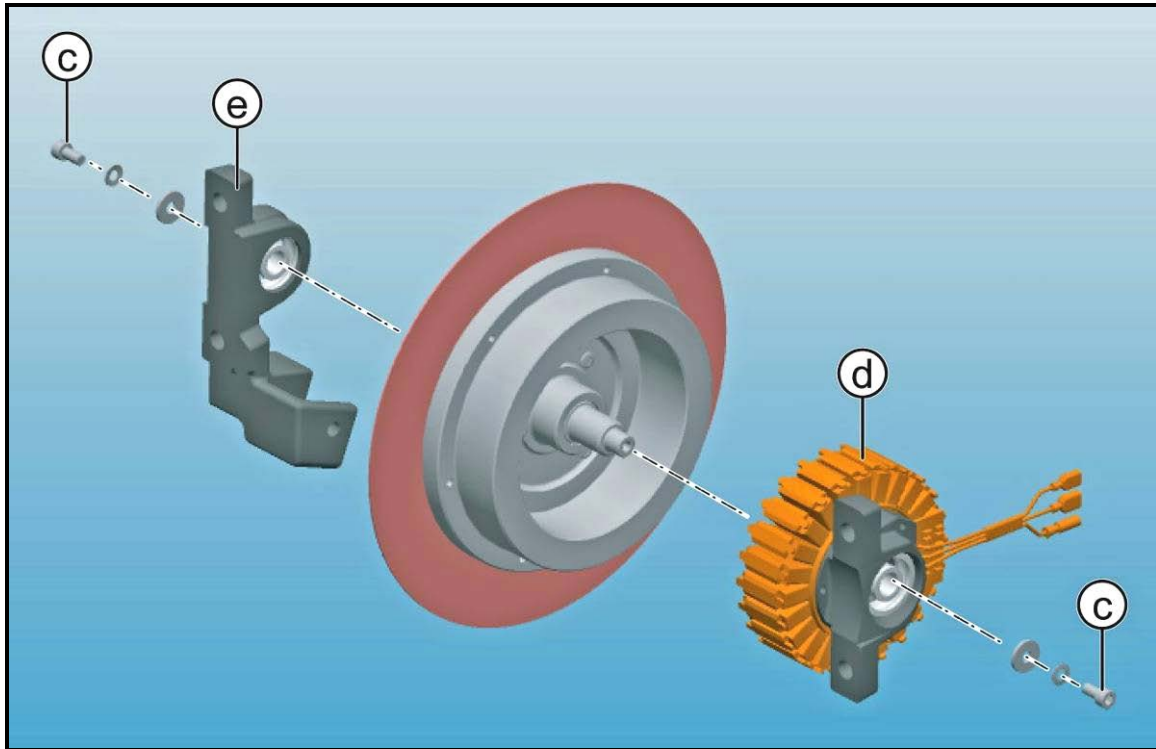


Figure 7.14-8

1. Back off the 2 screws (c) with two 5mm hexagonal wrenches, one opposite to the other.
2. Remove the stator group (d) and the belt tension system support (e) on the opposite side.



WARNING: During reassembly, lock down the screws (c) using a torque wrench setting of 10Nm and using the LOCTITE 243.

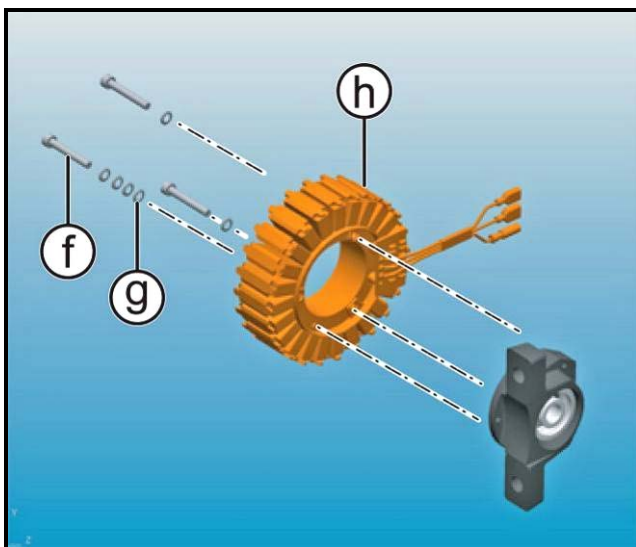


Figure 7.14-9

3. Back off the 3 screws (f) with a 4mm hexagonal wrench and the relative flat spring (g).
4. Remove and/or replace the stator (h) if necessary.



CAUTION: The screws (f), should be tightened using a torque wrench setting of 22 Nm.

To reassemble the stator, carry out the above steps in reverse order.



WARNING: Remember to place all 4 flat springs “g” again on the screw (f); otherwise you can not tighten properly.

7.15. DISASSEMBLING THE SPEED SENSOR



Only for powered version: 500, 700 and 700VISIO.

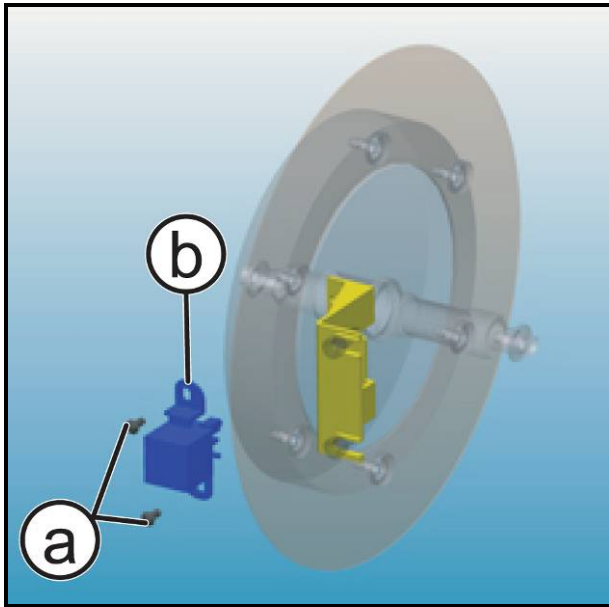


Figure 7.15-1

Carry out the operations described in paragraph: 7.7.1. “Rear guard”.

1. Back off the 2 screws (a) with a medium Phillips screwdriver.
2. Remove and/or replace the speed sensor (b).

To reassemble the speed sensor, carry out the above steps in reverse order.



CAUTION: After completing the reassembly, carry out the adjustment procedure described in paragraph: 8.2. “Speed sensor positioning”.

7.16. DISASSEMBLING THE BATTERY



Only for powered version: 500SP and 700SP.



Figure 7.16-1

Carry out the operations described in paragraphs: 7.7.2. “Brake box cover guard” and 7.7.3. “Front guards”.

1. Disconnect the 2 Faston highlighted in the figure
2. Remove the battery.

To reassemble the battery, carry out the above steps in reverse order

7.17. DISASSEMBLING THE FOOTBOARDS, POWER ENTRY MODULE AND WHEELS

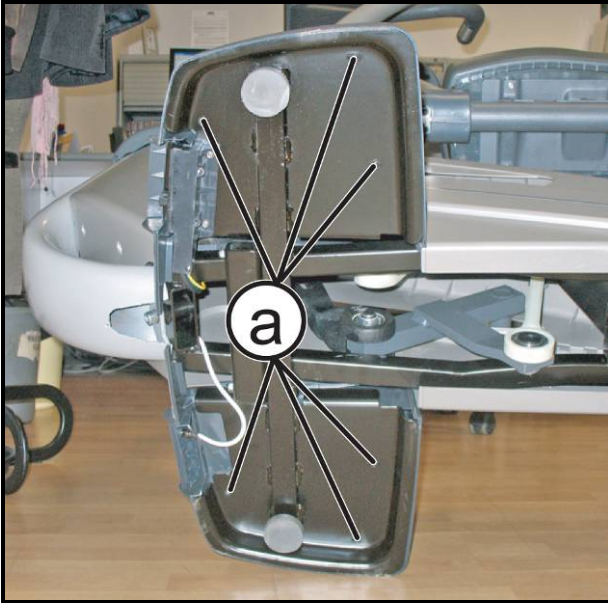


Figure 7.17-1

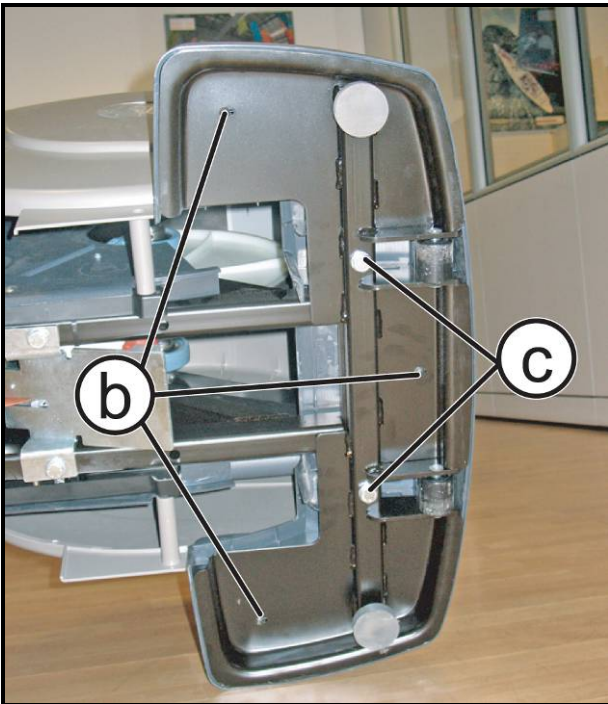


Figure 7.17-2

Front Footboard:

Carry out the operations described in paragraph: 7.7.3. "Front guards".

1. Turn the machine on one side.
2. Back off the 6 screws (a) on the front footboard, with a medium Phillips screwdriver.

Rear Footboard:

Carry out the operations described in paragraph: 7.7.1. "Rear guard".

3. Back off the 3 screws (b) on the rear footboard, with a medium Phillips screwdriver and the 2 screws (c) with a 17mm wrench.

Continued in following page...

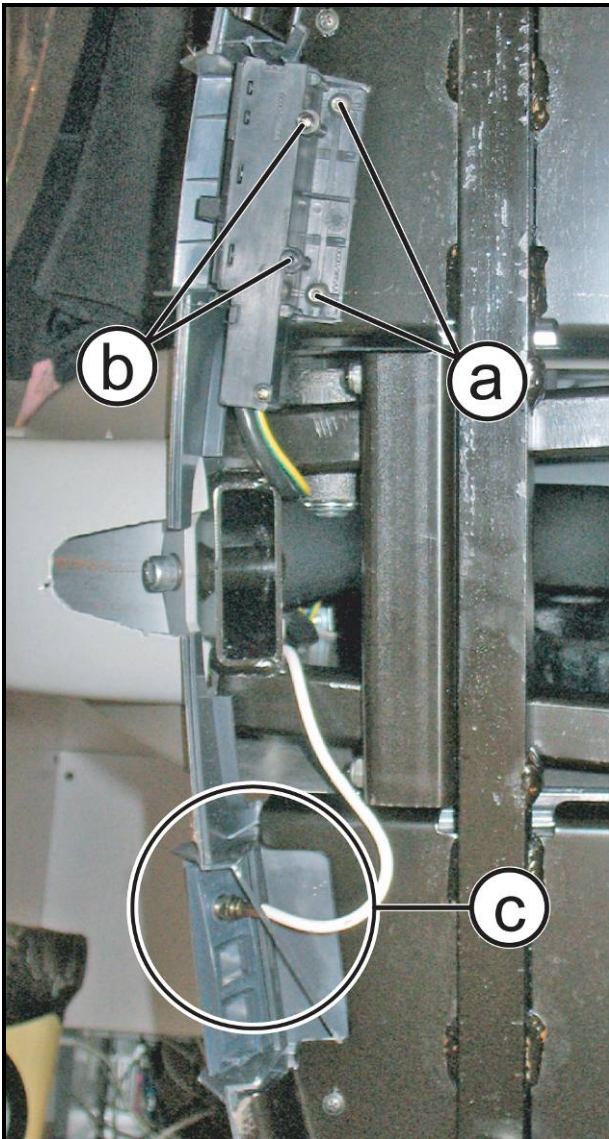


Figure 7.17-3

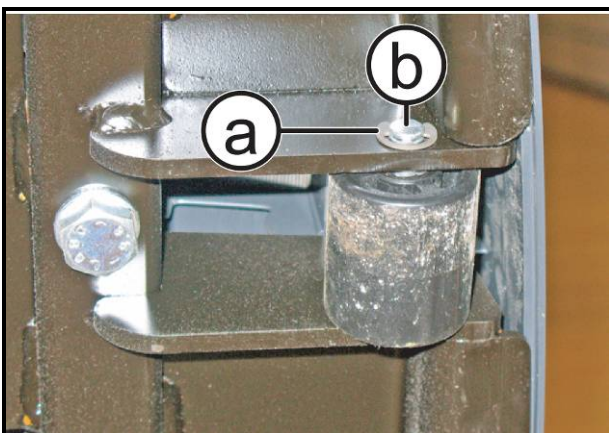


Figure 7.17-4

Power entry module (only powered models):

1. Back off the 2 screws **(a)**, with a 4mm hexagonal wrench.
2. Back off the 2 screws **(b)** with a small Phillips screwdriver, for remove the cover.
3. Remove the power entry module.

VISIO models:

4. Back off the antenna cable **(c)** from the footboards.

Wheels disassembly:

1. Remove the snap ring **(a)** on both the sides.
2. Remove the central pin **(b)**.
3. Remove the wheel and replace if necessary.

To reassemble the footboards, the power entry module and the wheels, carry out the above steps in reverse order.

8. ADJUSTMENT

8.1. BELT TENSION

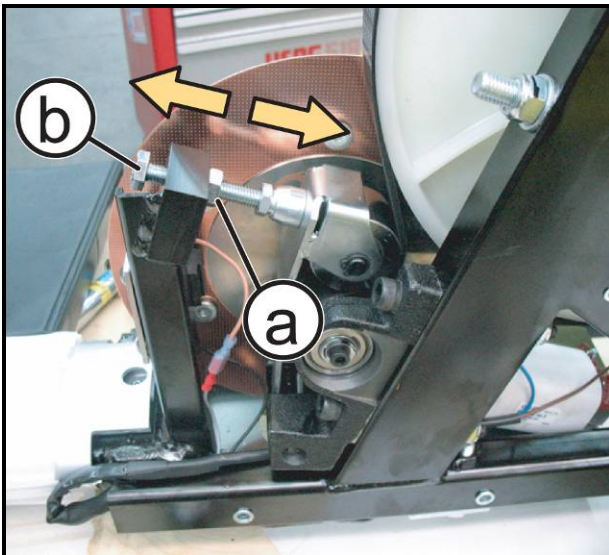


Figure 8.1-1

1. Back off the nut (a) with a 17mm wrench.
2. Adjust the tension acting on the screw (b) with a 17mm wrench, as indicated by arrows in figure.
3. Tighten the nut (a) again.

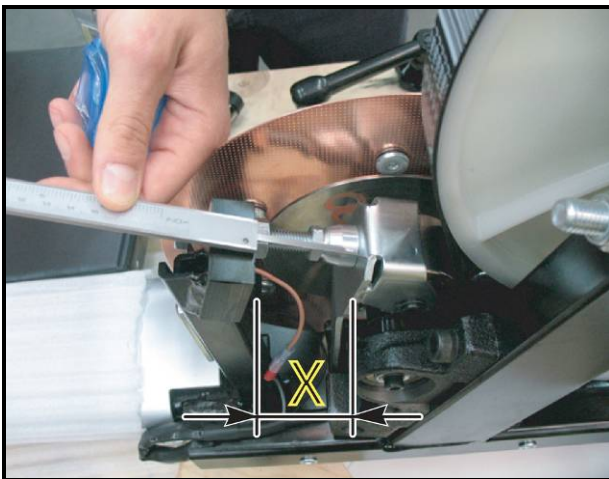


Figure 8.1-2

CAUTION: The right tension of belt must be 230Hz±10Hz. If the belt is new, the measure “X” should be approximately 51mm.

8.2. SPEED SENSOR POSITIONING



Only for powered version (500, 700 e 700WTV).

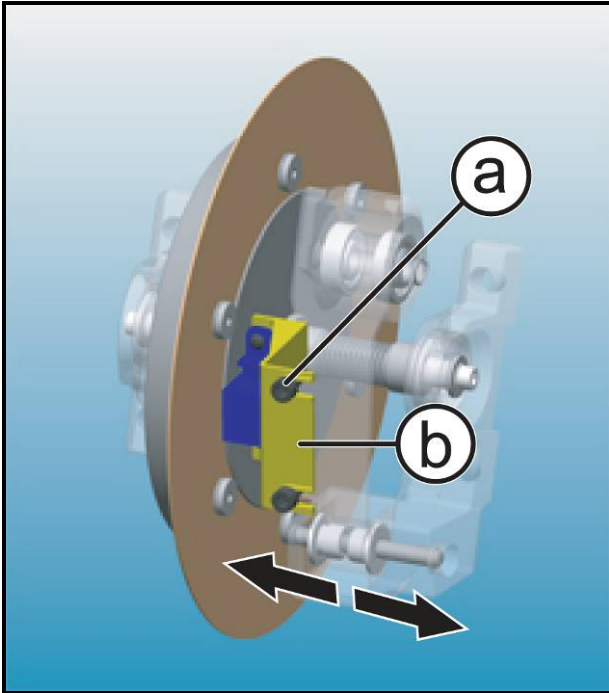


Figure 8.2-1

1. Loosen the 2 screws (a) and move the speed sensor support (b) laterally, as indicated by arrows.

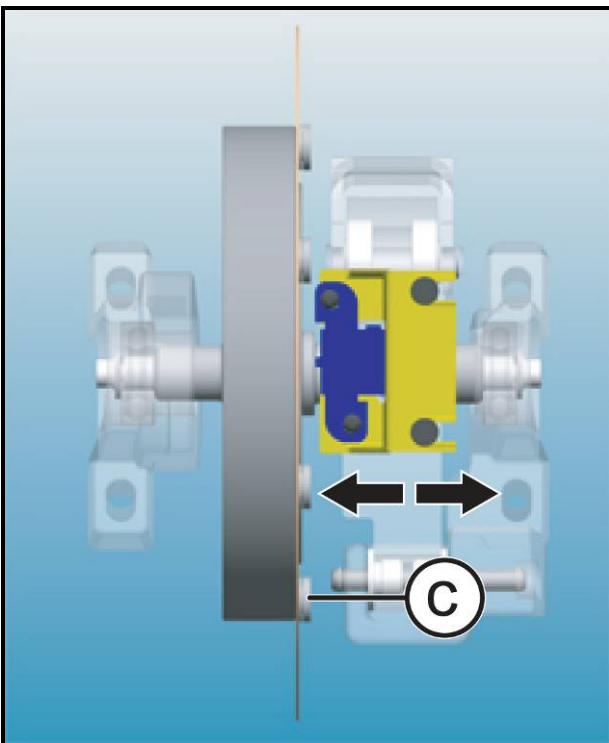


Figure 8.2-2

2. Adjust the speed sensor so that it is 0.7 mm from the screws heads (c) on copper dick.
3. Tighten the screws (a) again.

8.3. BRAKE WINDING POSITIONING

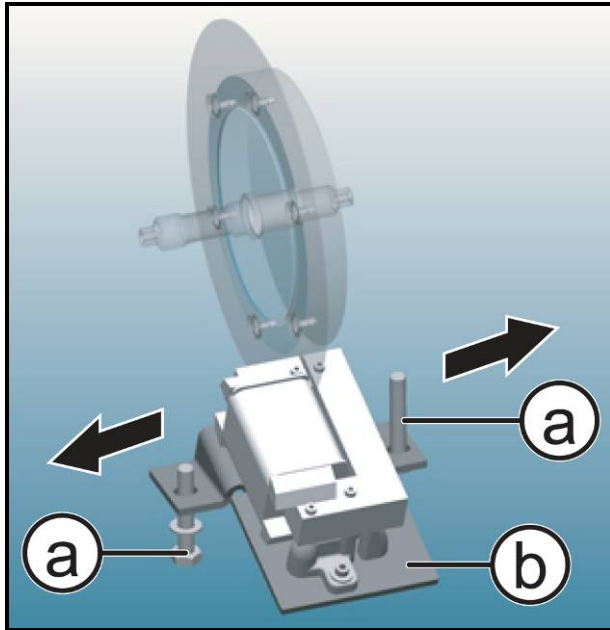


Figure 8.3-1

Carry out the operations described in paragraph: 7.7.1. "Rear guard".

1. Loosen the 2 screws (a) with a 17mm wrench.
2. Move the brake winding plate support (b), horizontally as indicated by arrows, so that the copper disk is centred on the brake winding, using a **1mm** thickness gauge.
3. Tighten again the screws.



ATTENTION: To correctly adjust the brake position, test the machine at high levels and check that the flywheel it is not touching on it.



WARNING: Use a flatness comparator to check the copper disk flatness, the permissible margin is ± 0.15 mm.

8.4. THE MACHINE IS NOT FLAT

This problem may be due to the positioning of the machine on a not flat surface. To solve this problem it is necessary to act on foot adjustment.

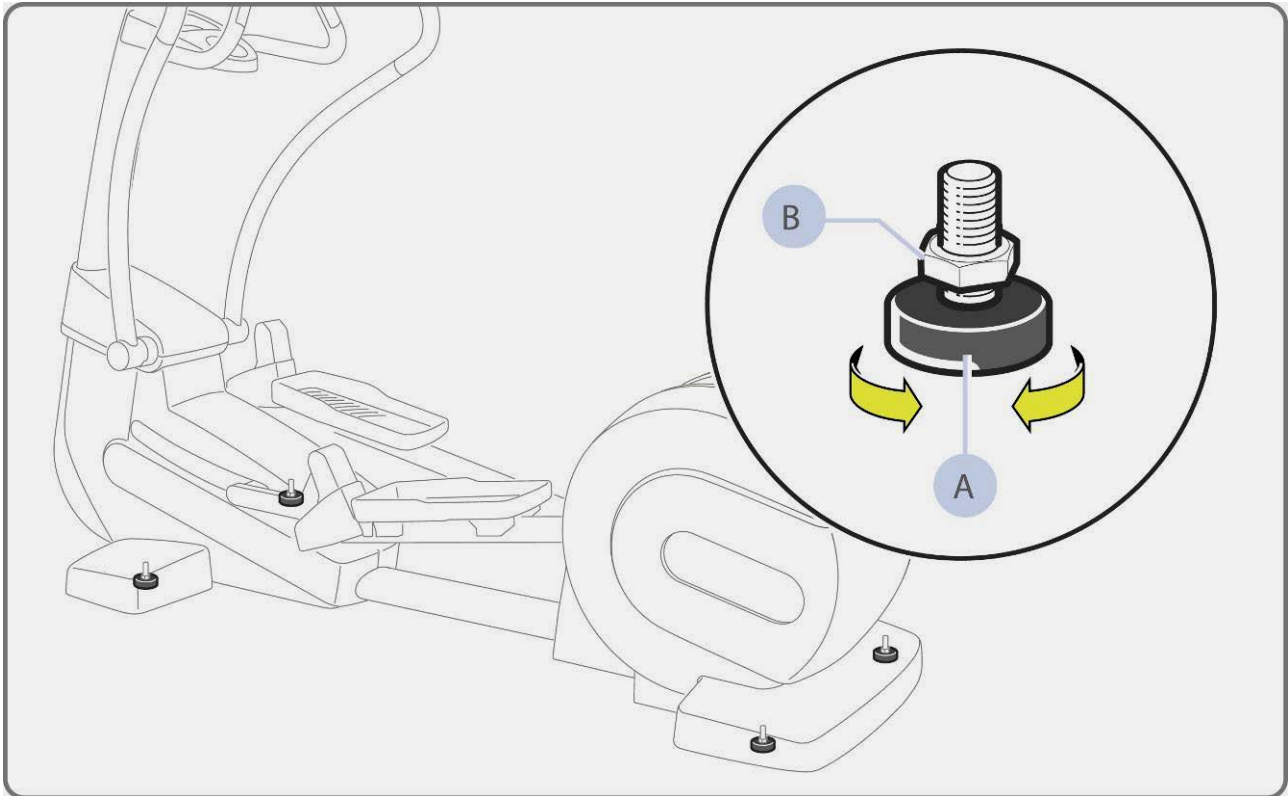


Figure 8.4-1

The equipment is levelled by adjusting the two front feet and the two rear feet:

1. Screw the foot (**a**) in or out until the frame is in a stable position.
2. Adjustment made to tighten the counter-nut (**b**).

9. MACHINE CONFIGURATION

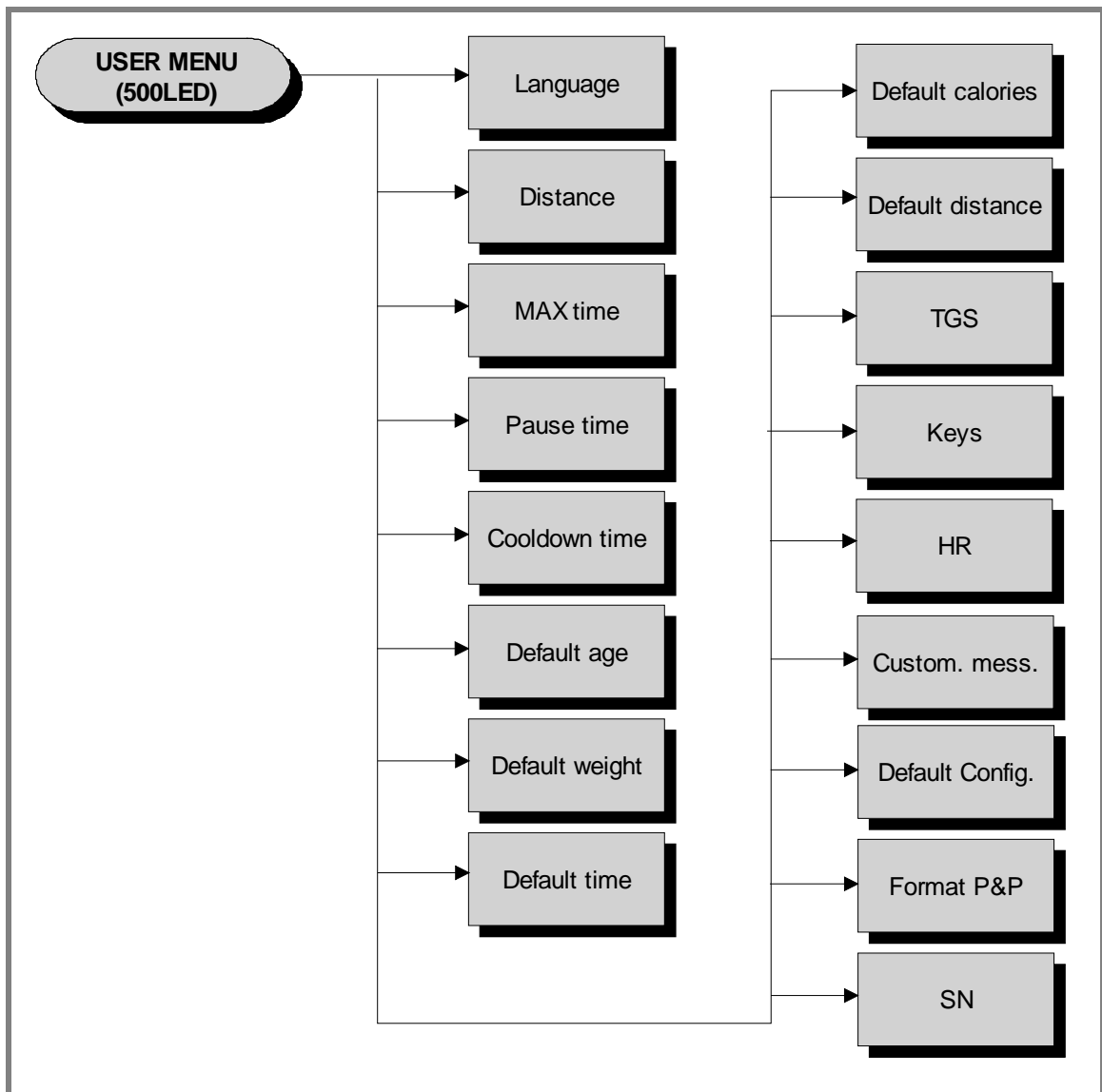
9.1. USER MENU CONFIGURATION: 500LED MODELS


The machine configuration procedure is invoked, when the machine is in standby mode, by simultaneously pressing the keys **ENTER**, **↑**, **CLEAR**. The following prompt appears on the display:

ENTER PASSWORD:

To access the procedure, type in the password **2406** and press **ENTER** to confirm. To enter the password, increase or decrease the displayed value using the **↑** and **↓** keys, or use the **+/- GOAL** keys to scroll through and modify the individual digits.

At this point the machine display begins showing the current configuration, structured as in the diagram below:



- 
To scroll through the list of available functions, press the + or – speed keys to display the next or the preceding item; confirm the choice by pressing ENTER. To cancel the operation, press the CLEAR key for a few seconds.

9.1.1. LANGUAGE

After selecting a language from the list of those available, all messages subsequently displayed by the machine will be in the chosen language. To change the selection, when the display shows the current setting:

LANGUAGE: xxx

Press the +/- **GOAL** keys to select the desired language from the available options.

9.1.2. UNITS OF MEASUREMENT

It is possible to choose between EUROPEAN units, kilograms (kg) and kilometers (km) or IMPERIAL units, Pounds (lb) and Miles (mi). To change the selection, when the display shows the current setting:

UNITS : xxx

Press the +/- **GOAL** keys to select the desired unit of measurement from the options listed in the table below:

UNITS	
KG	<i><default></i>
POUNDS	

9.1.3. MAXIMUM EXERCISE TIME

It is possible to set a maximum duration for each exercise, ranging from 1 to 9999 minutes. To change the setting, when the display shows the currently selected duration:

MAX. DURATION : xxx

Press the **ENTER** key to change the value: The current parameter value starts to blink on the display; use the ↑ and ↓ keys to increase or decrease the value, or use the +/- **GOAL** keys to scroll through and modify the individual digits.

The default value of this parameter is 9999.

9.1.4. PAUSE TIME

It is possible to set a maximum pause time for each exercise, ranging from 10 to 999 seconds. To change the setting, when the display shows the currently selected maximum time:

PAUSE TIME xxx

Press the **ENTER** key to change the value: The current parameter value starts to blink on the display; use the **↑** and **↓** keys to increase or decrease the value, or use the **+/- GOAL** keys to scroll through and modify the individual digits.

The default value of this parameter is 120.

9.1.5. COOLDOWN TIME

It is possible to set the cooldown time for each exercise, ranging from 5 to 180 seconds. To change the setting, when the display shows the currently selected maximum time:

COOLDOWN TIME xxx

Press the **ENTER** key to change the value: The current parameter value starts to blink on the display; use the **↑** and **↓** keys to increase or decrease the value, or use the **+/- GOAL** keys to scroll through and modify the individual digits.

The default value of this parameter is 60.

⏏ If you are exercising with a TGS key, the cooldown will be stopped if you extract the key.

9.1.6. DEFAULT AGE

It is possible to set the default age for a generic user, ranging from 10 to 99 years. To change the setting, when the display shows the currently selected default age:

DEFAULT AGE xx

Press the **ENTER** key to change the value: The current parameter value starts to blink on the display; use the **↑** and **↓** keys to increase or decrease the value, or use the **+/- GOAL** keys to scroll through and modify the individual digits

The default value of this parameter is 30.

9.1.7. DEFAULT WEIGHT

It is possible to set the default weight for a generic user, ranging from 10 to 99 kilograms. To change the setting, when the display shows the currently selected default weight:

DEFAULT WEIGHT KG xx

Press the **ENTER** key to change the parameter: The current parameter value starts to blink on the display; use the **↑** and **↓** keys to increase or decrease the value, or use the **+/- GOAL** keys to scroll through and modify the individual digits.

The default value of this parameter is 70.

9.1.8. DEFAULT DURATION

It is possible to set a maximum duration for the exercise session, with a value ranging from 1 to 999 minutes. To change the setting, when the display shows the current duration:

DEFAULT DURATION MIN. xxx

Press the **ENTER** key to change the parameter: The current parameter value starts to blink on the display; use the **↑** and **↓** keys to increase or decrease the value, or use the **+/- GOAL** keys to scroll through and modify the individual digits.

The default value of this parameter is 15 minutes.

9.1.9. DEFAULT CALORIES

It is possible to set the default calories for an exercise session, with a value ranging from 10 to 999. To change the setting, when the display shows the current value:

DEFAULT CALORIES xxx

Press the **ENTER** key to modify the value: The current parameter value starts to blink on the display; use the **↑** and **↓** keys to increase or decrease the value, or use the **+/- GOAL** keys to scroll through and modify the individual digits.

The default value of this parameter is 300.

9.1.10. DEFAULT DISTANCE

It is possible to set the default distance for an exercise session, with values ranging from 1 to 999. To change the setting, when the display shows the current value:

DEFAULT DISTANCE KM xxx

Press the **ENTER** key to modify the value: The current parameter value starts to blink on the display; use the **↑** and **↓** keys to increase or decrease the value, or use the **+/- GOAL** keys to scroll through and modify the individual digits.

The default value of this parameter is 10.

9.1.11. ENABLE TGS

It is possible to enable or disable the use of the TGS reader. To change the selection, when the display shows the current setting:

TGS : xxx

Press the **+/- GOAL** keys to select the desired option out of those listed in the table below:

TGS	
ENABLED	<default>
DISABLED	

9.1.12. ENABLE KEYBOARD

It is possible to disable the keyboard so that the machine can only be used with the TGS. To change the selection, when the display shows the current setting:

KEYS : xxx

Press the **+/- GOAL** keys to select the desired option out of those listed in the table below:

KEYS	
ENABLED	<default>
DISABLED	

9.1.13. MODIFIABLE TARGET FREQUENCIES

It is possible to enable or disable modification of the target heart rate during a constant heart rate exercise. To change the selection, when the display shows the current setting:

HR : xxx

Press the +/- **GOAL** number keys to select the desired option out of those listed in the table below:

HR
MODIFIABLE <default>
NON MODIFIABLE

9.1.14. ENABLE CUSTOM MESSAGES

It is possible to configure whether a custom message is displayed when the machine is in the standby state. To change the selection, when the display shows the current setting:

CUSTOM MESS. : xxx

Press the +/- **GOAL** number keys to select the desired option out of those listed in the table below:

CUSTOM MESS.
YES <default>
NO

9.1.15. RESETTING PARAMETERS TO DEFAULT VALUES

It is possible to reset the user menu parameters to their default values. To select the function, when the display shows:

DEFAULT CONFIG.

Press **ENTER** to confirm the operation, use the + or – effort level keys to move to the next or preceding parameter. If the **ENTER** key is pressed the display will show:

CONFIRM ?

press **ENTER** to confirm, or cancel by pressing the **CLEAR** key for a few seconds.

9.1.16. FORMAT P&P KEY

This function formats a TGS key for Plug&Play mode operation. To select the function, when the display shows:

FORMAT P&P

Press **ENTER** to confirm. At the end of the formatting procedure, hold down the **CLEAR** key for a few seconds to exit. The **CLEAR** key can be pressed at any time to interrupt the procedure and revert to standby mode.

9.1.17. SN

This parameter shows the serial number of the machine.

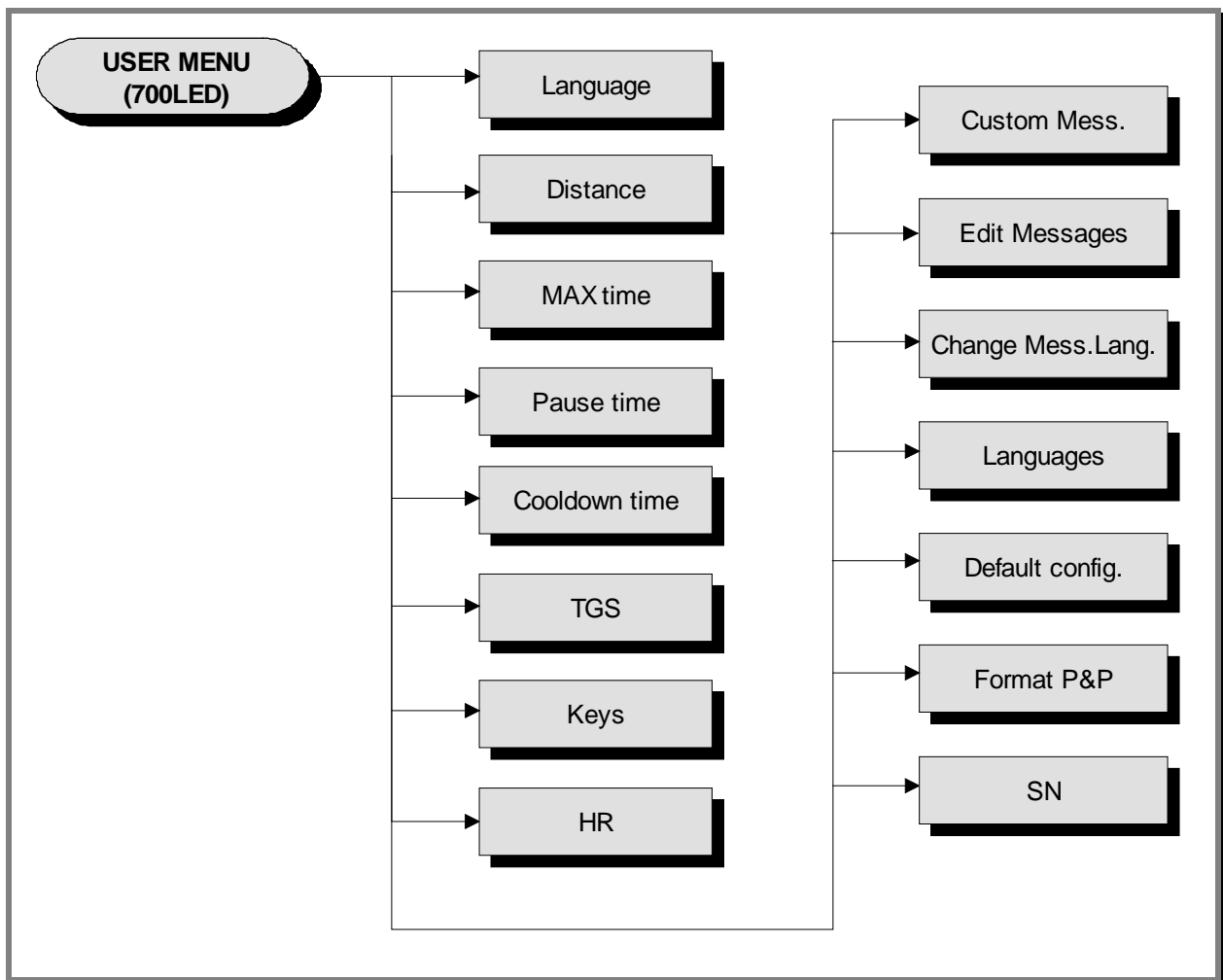
SN:xxxxxx


9.2. USER MENU CONFIGURATION: 700LED MODELS

The machine configuration procedure is invoked, when the machine is in standby mode, by simultaneously pressing the keys **369**.

ENTER PASSWORD:

To access the procedure, type in the password **2406** and press **ENTER** to confirm. At this point the machine display begins showing the current configuration, structured as in the diagram below:



- 
To scroll through the list of available functions, press the + or – speed keys to display the next or the preceding item; confirm the choice by pressing ENTER. To cancel the operation, press the CLEAR key for a few seconds.

9.2.1. LANGUAGE

After selecting a language from the list of those available, all messages subsequently displayed by the machine will be in the chosen language. To change the selection, when the display shows the current setting:

LANGUAGE : xxx

Press the +/- **GOAL** keys to select the desired language from the options available.

9.2.2. DISTANCE

It is possible to choose between EUROPEAN units (kg and km) or IMPERIAL units (pounds and miles). To change the selection, when the display shows the current setting:

DISTANCE : xxx

Press the +/- **GOAL** keys to select the desired unit of measurement from the options listed in the table below:

DISTANCE	
KM	<default>
MLS	

9.2.3. MAXIMUM EXERCISE TIME

It is possible to set a maximum duration for the exercise in minutes, with a value ranging from 1 to 9999. To change the setting, when the display shows the current maximum exercise time:

MAX TIME: xxx

Press the **ENTER** key to modify the value: when the current parameter value starts to blink, press the **CLEAR** key to erase the current value and then use the number keys to enter the desired new value.

The default value of this parameter is 9999.

9.2.4. PAUSE TIME

It is possible to set a maximum pause time for each exercise in seconds, with values ranging from 10 to 999. To change the setting, when the display shows the current maximum time:

PAUSE TIME : xxx

Press the **ENTER** key to modify the value: when the current parameter value starts to blink, press the **CLEAR** key to erase the current value and then use the number keys to enter the desired new value.

The default value of this parameter is 60.

9.2.5. COOLDOWN TIME

It is possible to set the cooldown time for each exercise, ranging from 5 to 180 seconds. To change the setting, when the display shows the currently selected maximum time:

COOLDOWN TIME **xxx**

Press the **ENTER** key to change the value: The current parameter value starts to blink on the display; use the **↑** and **↓** keys to increase or decrease the value, or use the **+/- GOAL** keys to scroll through and modify the individual digits.

The default value of this parameter is 60.

If you are exercising with a TGS key, the cooldown will be stopped if you extract the key.

9.2.6. ENABLE TGS

It is possible to enable or disable the use of the TGS reader. To change the selection, when the display shows the current setting:

TGS : **xxx**

Press the **+/- GOAL** keys to select the desired option out of those listed in the table below:

TGS	
ENABLED	<default>
DISABLED	

9.2.7. ENABLE KEYBOARD

It is possible to disable the keyboard so that the machine can only be used with the TGS. To change the selection, when the display shows the current setting:

KEYS : **xxx**

Press the **+/- GOAL** keys to select the desired option out of those listed in the table below:

KEYS	
ENABLED	<default>
DISABLED	

9.2.8. MODIFIABLE TARGET HEART RATE

It is possible to enable or disable modification of the target heart rate during a constant heart rate exercise. To change the selection, when the display shows the current setting:

HR : xxx

Press the +/- **GOAL** number keys to select the desired option out of those listed in the table below:

HR
MODIFIABLE <default>
NOT MODIFIABLE

9.2.9. ENABLE CUSTOM MESSAGES

It is possible to configure whether a custom message is displayed when the machine is in the standby state. To change the selection, when the display shows the current setting:

CUSTOM MESS. : xxx

Press the +/- **GOAL** number keys to select the desired option out of those listed in the table below:

CUSTOM MESS.
YES <default>
NO

9.2.10. EDIT CUSTOM MESSAGES

It is possible to modify the custom messages; press **ENTER** to invoke a submenu which displays the first custom message, then use the +/- effort level keys to move to the other messages. Press the **ENTER** key again to begin editing a message, or hold down the **CLEAR** key for a few seconds to return to the upper menu level. While editing a message, move the cursor using +/- **GOAL**, select the desired letter using the +/- effort level keys and use **CLEAR** to enter a blank space character.

Press **ENTER** to save the modified message, or hold down the **CLEAR** key to cancel and return to the upper menu level.

9.2.11. CHANGE MESSAGES LANGUAGES

It is also possible to display the custom standby messages in the language selected with the preceding parameter. To extend the language setting to the predefined custom standby messages, when the LED display is showing the current selection:

CHANGE MESS. LANGUAGE

9.2.12. ENABLE MULTI-LANGUAGE MODE

The machine can be configured to allow selection of the language at each session. To change the selection, when the display shows the current setting:

LANGUAGE : xxx

Press the +/- **GOAL** number keys to select the desired option out of those listed in the table below:

LANGUAGE	
FIXED	<default>
OPTIONAL	

9.2.13. RESETTING PARAMETERS TO DEFAULT VALUES

It is possible to reset the user menu parameters to their default values. To select the function, when the display shows:

DEFAULT CONFIG.

Press **ENTER** to confirm the operation, use the + or – effort level keys to move to the next or preceding parameter. If the **ENTER** key is pressed the LED matrix will show:

CONFIRM ?

Press **ENTER** to confirm, or cancel by pressing the **CLEAR** key for a few seconds.

9.2.14. FORMAT P&P

This function formats a TGS key for Plug&Play mode operation. To select the function, when the display shows:

FORMAT P&P

Press **ENTER** to confirm, or cancel by pressing the **CLEAR** key for a few seconds.

At the end of the configuration procedure, hold down the **CLEAR** key for a few seconds to exit. The **CLEAR** key can be pressed at any time to interrupt the procedure and revert to standby mode.

9.2.15. SN

This parameter shows the serial number of the machine.

SN : xxxxx

9.3. SERVICE MENU CONFIGURATION: LED MODELS

The configuration procedure is invoked when the machine is in standby mode, using a different procedure for the 500 and 700 models.

9.3.1. ACCESSING CONFIGURATION OF 500 MODELS

Simultaneously press the **ENTER**, **↑**, **CLEAR** keys. The following prompt appears on the display:

ENTER PASSWORD:

To access the procedure, type in the password **2501** which protects against unauthorized access and press **ENTER** to confirm. To enter the password, increase or decrease the displayed value using the **↑** and **↓** keys, or use the **+/- GOAL** keys to scroll through and modify the individual digits.

At this point there are two options available:

↑ = Tech Config
↓ = Troubleshooting

Press numeric key **↑** to access the *menu for configuring technical parameters*; the machine display will begin showing the current configuration, structured as in the diagram below:

9.3.2. ACCESSING CONFIGURATION OF 700 MODELS

The setup procedure of the equipment is activated when the machine is in Stand-by.

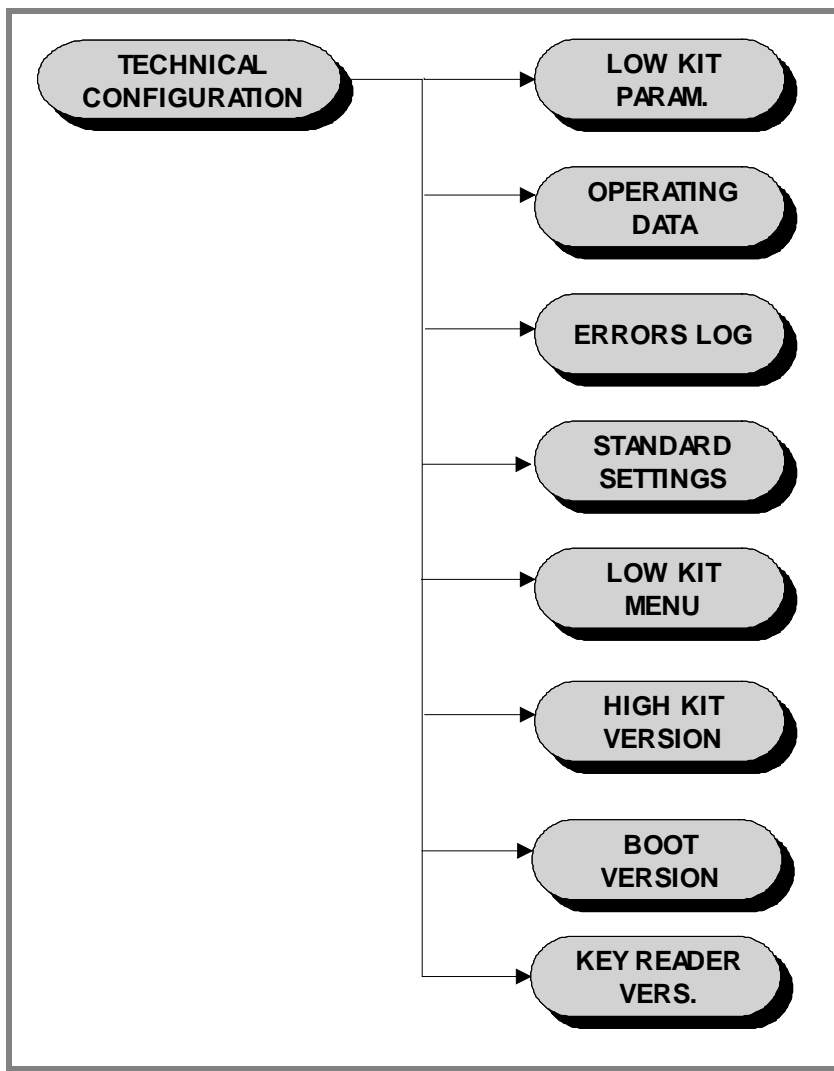
Simultaneously press the keys **369** for 700 models. The following prompt appears on the display:

ENTER PASSWORD:

To access the procedure, type in the password **2501** which protects against unauthorized access and press the “Enter” key to confirm. At this point there are two options available:

1 = Tech Config
2 = Troubleshooting

Press numeric key **1** to access *the menu for configuring technical parameters*; the machine display will begin showing the current configuration, structured as in the diagram below:



To scroll through the list of parameters, press the + or – effort level keys to display the next or the preceding item.

To modify a parameter value, it is necessary to press the **ENTER** key: when the current parameter value starts to blink, press the **CLEAR** key to erase the current value and then use the number keys to enter the desired new value. Save the changes made by pressing the **ENTER** key.

To cancel the operation, press the **CLEAR** key for a few seconds.

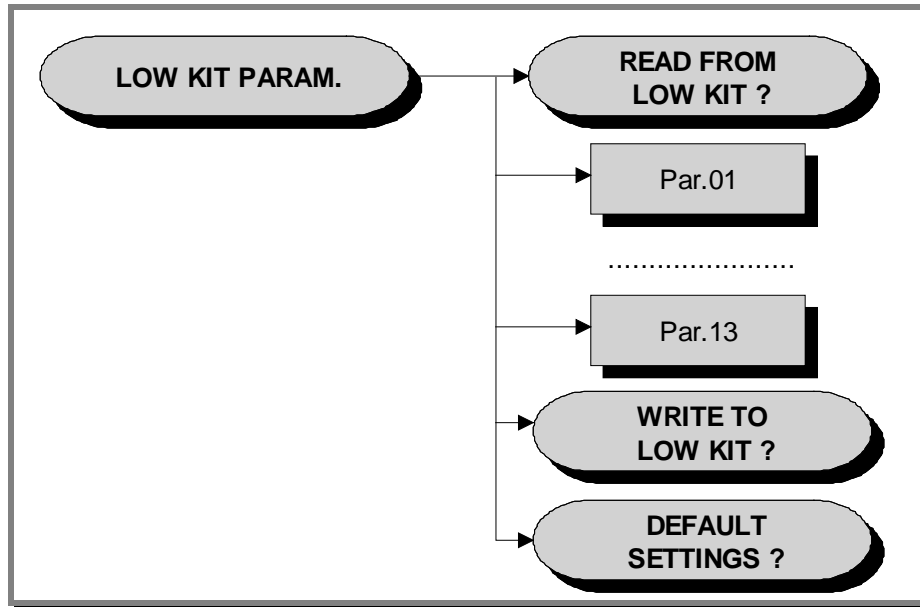
The various parameters are described below.

9.3.3. LOW KIT PARAMETER

This function provides access to parameters used for modifying certain settings of the lower assembly. To access this menu, when the display shows:

LOW KIT PARAM.

Press **ENTER**. This function is structured as follows:



In addition to the 13 configuration parameters, this function also includes the 3 sub-functions described below:

9.3.3.1. Read from low kit

To read the parameter values from the low kit memory and view them on the display, scroll using the +/- keys until the display shows:

READ FROM LOW KIT ?

Press **ENTER** to read the errors from the low kit, and return to the upper menu level by pressing **CLEAR** for a few seconds.

9.3.3.2. Write to low kit

To write the values of the currently displayed parameters to the low kit, scroll using the +/- keys until the display shows:

WRITE TO LOW KIT ?

Press **ENTER** to write the parameters to the low kit, and return to the upper menu level by pressing **CLEAR** for a few seconds.

9.3.3.3. Default Setting

To load the default parameter values, scroll using the +/- effort level keys until the display shows:

DEFAULT SETTING ?

Press **ENTER**. Display shows:

CONFIRM ?

Press **ENTER** to write the default values to the low kit, and return to the upper menu level by pressing **CLEAR** for a few seconds.



To write these parameters to the low kit, use the “Write to low kit” function.

9.3.3.4. Table of configuration parameters:

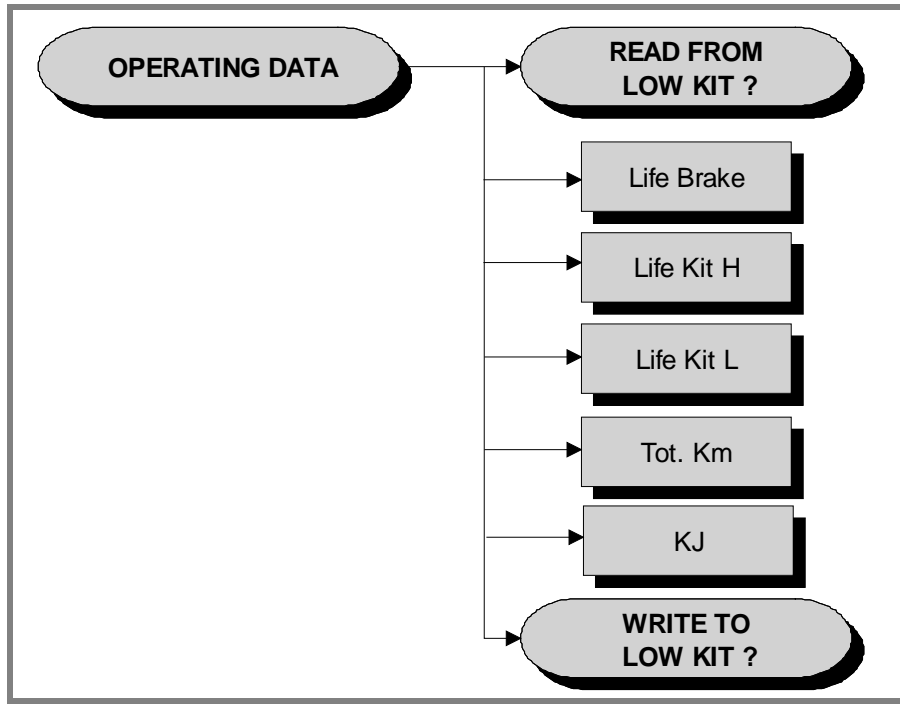
Id (Par.)	Units	Name	Description	LED	
				powered	Self-powered
1	decimal	[Rt]	Transmission Ratio	166	166
2		[Rvel]	Speed ratio	1	1
3	mA	[Im]	Minimum braking	0	0
4	W	[Pmc]	Constant maximum power	200	200
5	in cent	[Km]	Power factor correction (constant torque)	100	100
6	0.1N	[Ca]	User friction torque	23	23
7	°C	[Tea]	Maximum temperature on the coil	125	125
8	User Rpm	[RPMmin]	Minimum user SPM (start cut braking ramp)	35	35
9	Type/sec	[RpmF1]	Flywheel target RPM speed in standby (and power-on speed for self powered)	1	1
10	User Rpm	[RpmF2]	Rpm filter threshold	75	75
11		[Rvel]	Speed ratio (decimal part)	60	60
12	0.1N	[D_Ca]	User delta friction torque	6	6
13	-	-	Enable flag for registers at address ≥ 100	-	-

9.3.4. OPERATING DATA

This function makes it possible to access the machine usage data stored in the low kit. To access this menu, when the display shows:

OPERATING DATA

Press **ENTER**. This function is structured as follows:



In addition to the machine usage data, this function also includes the 2 sub-functions described below:

9.3.4.1. Read from low kit

To read the parameter values from the low kit memory and view them on the display, scroll using the +/- keys until the display shows:

READ FROM LOW KIT ?

Press **ENTER** to read the errors from the low kit, and return to the upper menu level by pressing **CLEAR** for a few seconds.

9.3.4.2. Write to low kit

To write the values of the currently displayed parameters to the low kit, scroll using the +/- keys until the display shows:

WRITE TO LOW KIT ?

Press **ENTER** to write the new data to the low kit, and return to the upper menu level by pressing **CLEAR** for a few seconds.

9.3.4.3. Machine usage data

The machine usage data on the display is updated every 10 minutes. This means that, whenever the machine is switched off, any data modified after the last memory update will be lost.

<i>Message on Display</i>	<i>Description</i>
<i>Life Brake:</i>	<i>Minutes x 10 of operation of the Brake (Detected by the Low Kit)</i>
<i>Life Kit High:</i>	<i>Minutes x 10 of operation of the High Kit (Detected by the High Kit)</i>
<i>Life Kit Low:</i>	<i>Minutes x 10 of operation of the Low Kit (Detected by the Low Kit)</i>
<i>KJ:</i>	<i>Total KJ (For all the exercises performed) (Detected by the High Kit)</i>
<i>Tot Km:</i>	<i>Total km travelled (For all the exercises performed) (Detected by the Low Kit)</i>

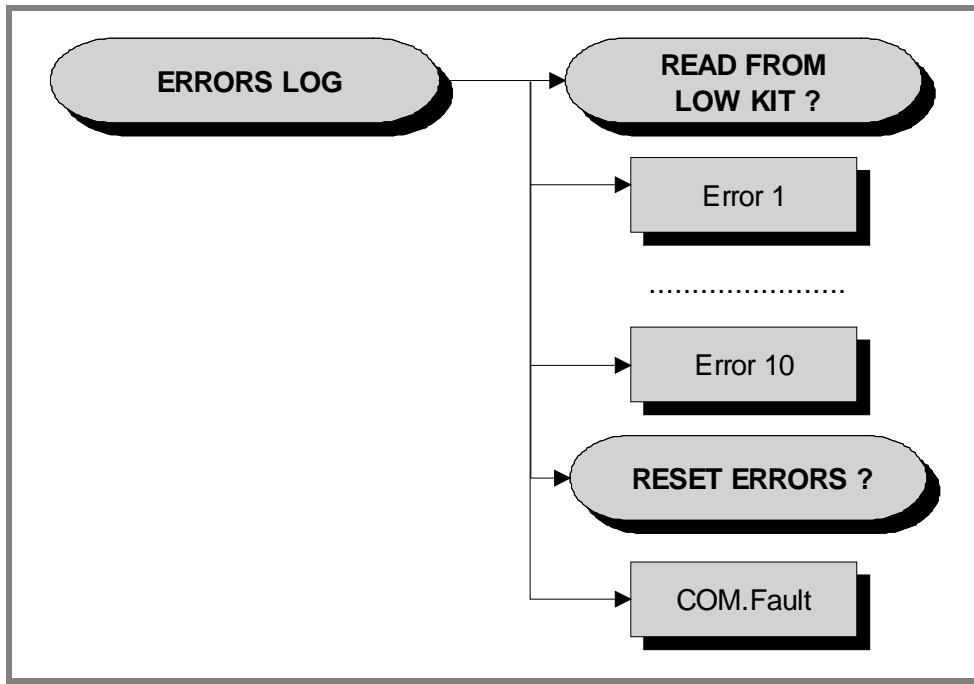
By selecting one of the items in the above table it is possible to modify its content, but only after having cleared its value. When the **ENTER** key is pressed the message "Reset life..." appears, followed by the name of the selected item; pressing **ENTER** again resets the value of the selected item, while pressing **CLEAR** reverts to the preceding value.

9.3.5. ERRORS LOG

This function accesses the machine's error history log. To access this menu, when the display shows:

ERRORS LOG

Press **ENTER**. This function is structured as follows:



In addition to the error history log, this function also includes the 3 sub-functions described below:

9.3.5.1. Read from low kit

To read the errors stored in low kit memory and view them on the display, scroll using the +/- keys until the display shows:

READ FROM LOW KIT ?

Press **ENTER** to read the errors from the low kit, and return to the upper menu level by pressing **CLEAR** for a few seconds.

9.3.5.2. Reset Errors

To clear the error history in both the low and high kit memory, scroll using the +/- keys until the display shows:

RESET ERRORS ?

Press **ENTER** to clear the error history logs, and return to the upper menu level by pressing **CLEAR** for a few seconds.

9.3.5.3. COM.Fault

This is a counter that displays the number of errors in serial communication between the upper and the lower kit. This counter increase each time a communication fault is detected. Scroll using the +/- keys until the display shows:

COM.FAULT X

To reset it press **ENTER**, the LED display shows:

RESET COM.FAULT?

Press **ENTER** to reset and return to the upper menu level by pressing **CLEAR** for a few seconds.

9.3.5.4. View Errors

For every error generated by the machine, the error history log records the information in the table below:

- *Counter*
- *Error code*
- *Current when the error occurred*
- *Distance in km when the error occurred*

The correspondence between error codes and descriptions is given in the table below:

<i>Error Code</i>	<i>Description</i>
1	<i>OVERHEATING:</i> <i>this condition occurs when the temperature detected by the sensor on the circuit board exceeds 90°C.</i>
8	<i>OVERVOLTAGE:</i> <i>this condition occurs when the +12Vdc voltage goes above 13.7Vdc (only for 700 LED and 700 VISIO).</i>

Use the + effort level key to advance to the next error, otherwise the message with the details of the current error will continue to reappear.

9.3.6. STANDARD SETTINGS

This function clears the operating data of the machine and simultaneously resets the brake board parameters to their default values. To access this menu, when the display shows:

STANDARD SETTINGS ?

Press **ENTER**, the following message appears:

CONFIRM ?

Press **ENTER** again to reset all parameters to their default values, or return to the upper menu level by pressing **CLEAR** for a few seconds.



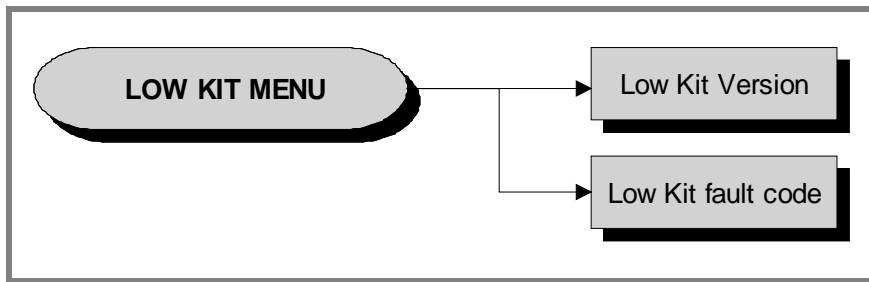
This function does not alter the language and the TV standard setting.

9.3.7. LOW KIT MENU

This function directly accesses the firmware of the brake board. To access this menu, when the display shows:

LOW KIT MENU

Press **ENTER**. This function is structured as follows:



9.3.7.1. Low kit version

This function displays the brake board firmware version. To access this menu, when the display shows:

LOW KIT VERSION

Press **ENTER**, the following message appears:

X.Y.Z

Where:

- *X = KERNEL*
- *Y = Brake Board*
- *Z = Brake Table*

Which identifies the firmware version.

9.3.7.2. Low Kit fault code

This function displays the error code that is blocking the low kit. To access this menu, when the display shows:

LOW KIT FAULT CODE

Press **ENTER**, the following message appears:

FAULT=XX



In case of FAULT=00, the board is not in an error condition.

9.3.8. HIGH KIT VERSION

This function displays the SW version of the display. To do this, when the display shows:

HIGH KIT VERSION

Press **ENTER**, the message that identifies the SW version, will appear.

9.3.9. BOOT VERSION

This function displays the BOOT version. To do this, when the display shows:

BOOT VERSION

Press **ENTER** to display the message which identifies the BOOT version.



The Boot Version parameter displays the boot SW version of display HW. The boot is the part of the SW, which allows uploading on the display the TG program. This parameter is just a visualization of the SW version and it can not be modified or updated.

9.3.10. KEY READER VERSION

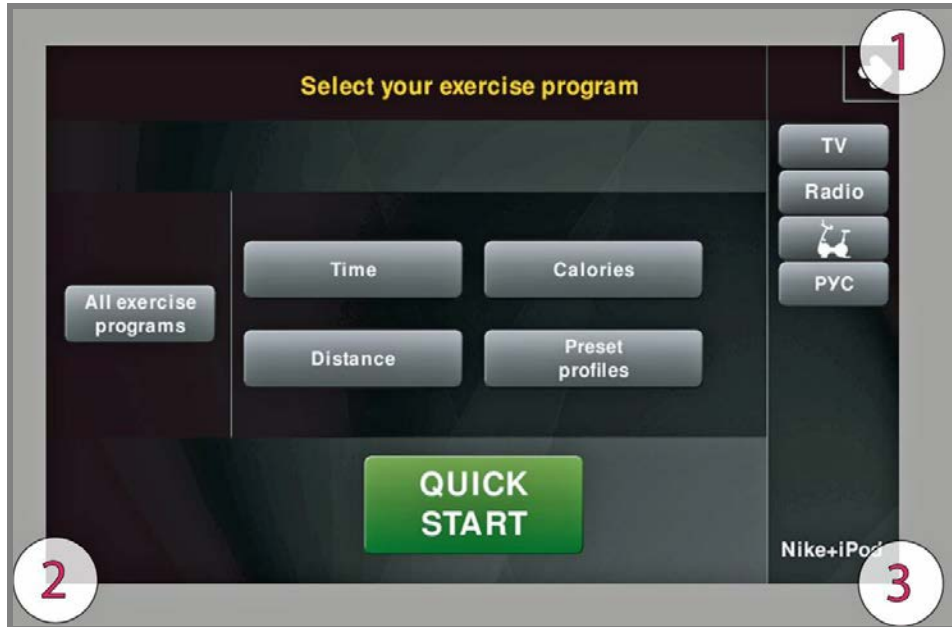
This function displays the KEY READER VERSION. To do this, when the display shows:

KEY READER VERSION

Press **ENTER** to display the message which identifies the KEY READER version.

9.4. CONFIG.: VISIO - VISIOWEB USER MENÙ

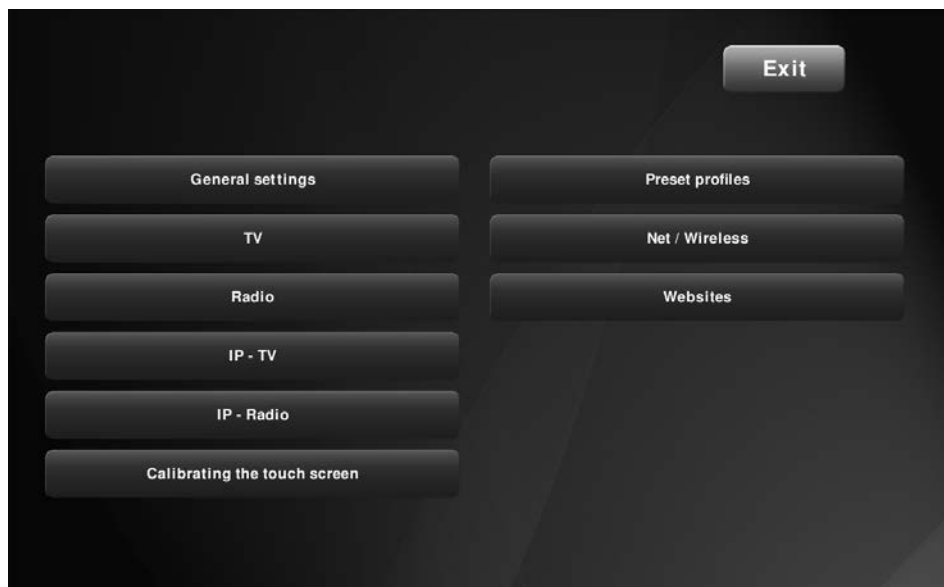
The procedure is activated by pressing the top right-hand corner, the bottom left-hand corner and the bottom right-hand corner of the screen in that sequence, in Stand-By, as shown in the figure below:



A new display will appear from which you can gain access to the various configuration menus, by entering the password on the number keyboard:

Enter the password **2406** and press the **ENTER** key to confirm or **EXIT** to quit.

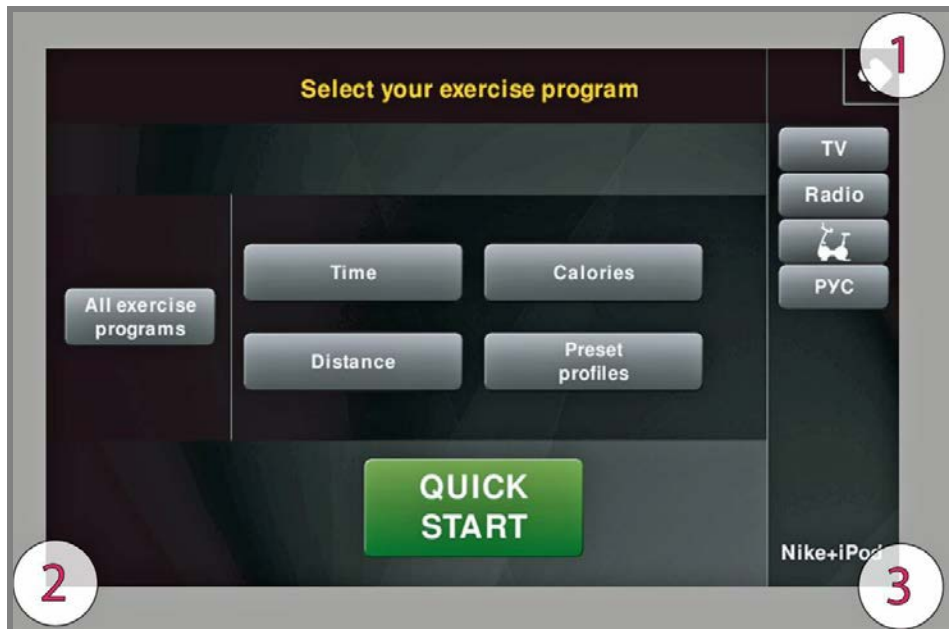
A menu will then appear which will provide access to the following sub-menus:



For the following menu, please refer to the relevant chapter in the VISIO manual.

9.5. SERVICE MENU CONFIG.: VISIO - VISIOWEB

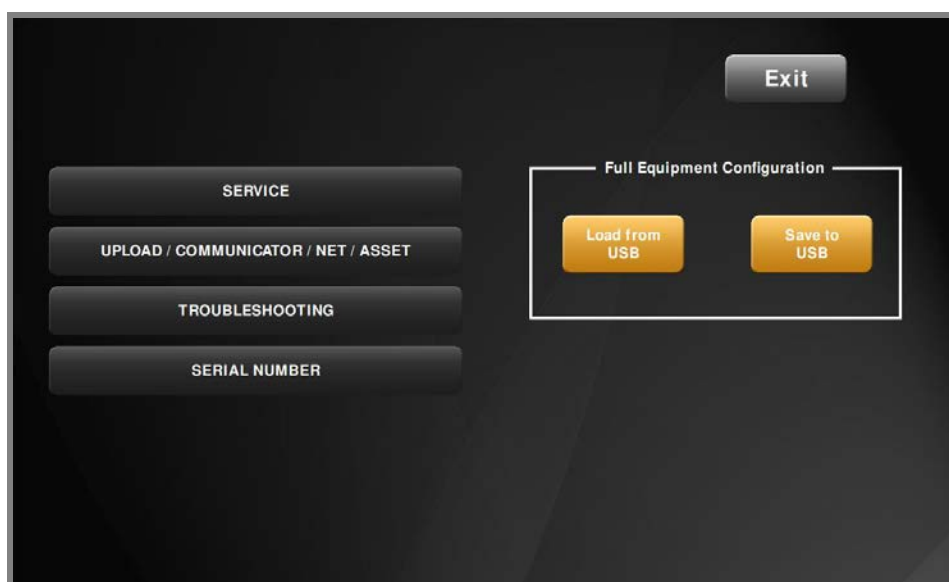
The procedure is activated by pressing the top right-hand corner, the bottom left-hand corner and the bottom right-hand corner of the screen in that sequence, in Stand-By, as shown in the figure below:



A new display will appear from which you can gain access to the various configuration menus, by entering the password on the number keyboard:

Enter the password **2501** and press the **ENTER** key to confirm or **EXIT** to quit.

A menu will then appear which will provide access to the following sub-menus:



For the following menu, please refer to the relevant chapter in the VISIO manual.

9.5.1.1. Table of configuration parameters



To correctly display the parameter values, you need to load them from the low kit, using the “Read from low kit” function.



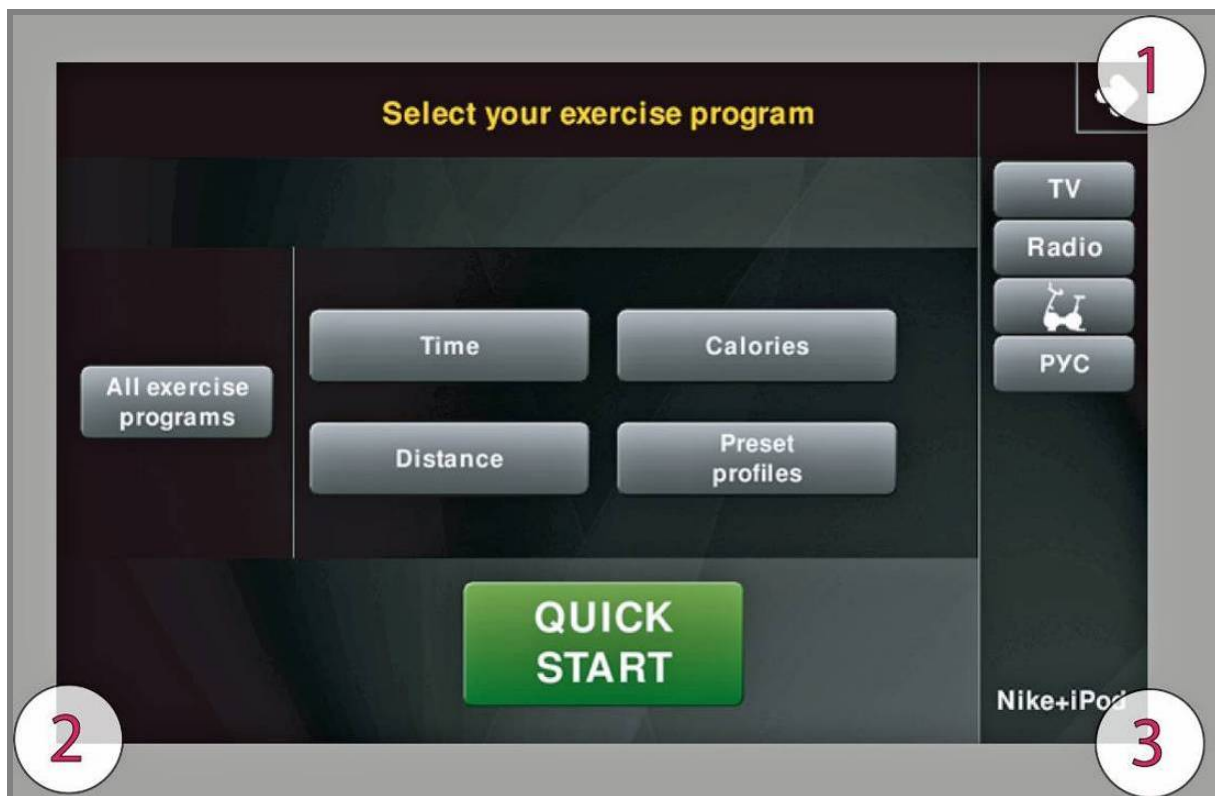
After any changes to the parameter values, you need to save them in the low kit using the “Write to low kit” function

Id (Par.)	Units	Name	Description	VISIO
				Powered.
1	decimal	[Rt]	Transmission Ratio	141
2		[Rvel]	Speed ratio	1
3	mA	[Im]	Minimum braking	0
4	W	[Pmc]	Constant maximum power	200
5	in cents	[Km]	Power factor correction (constant torque)	100
6	0.1N	[Ca]	User friction torque	60
7	°C	[Tea]	Maximum temperature on the coil	125
8	User rpm	[RPMmin]	Minimum user SPM (start cut braking ramp)	35
9	Type/sec	[RpmF1]	Flywheel target RPM speed in standby (and power-on speed for self powered)	1
10	User rpm	[RpmF2]	Rpm filter threshold	75
11		[Rvel]	Speed ratio (decimal part)	60
12	0.1N	[D_Ca]	User delta friction torque	10
13	-	-	Enable flag for registers at address ≥ 100	-

Page intentionally left blank.

10. UPDATING THE SW

The procedure is activated by pressing the top right-hand corner, the bottom left-hand corner and the bottom right-hand corner of the screen in that sequence when the equipment is in Stand-By, as shown in the figure below.



A new display will appear from which you can gain access to the various configuration menus, by entering the password on the number keyboard:

In order to access the menu, enter the password **2502** and press the **ENTER** key in order to confirm, **ESCI** in order to quit.



For the following menu, please refer to the relevant chapter in the **VISIO** manual.

Page intentionally left blank.

11. FUNCTIONAL TEST MD MODELS

Every time maintenance and/or repairs are performed on a machine, it is necessary to carry out a series of **mechanical** and **electrical tests** to ensure:

- *That the medical device is working properly;*
- *That the medical device is working safely;*
- *That the exercises are performed according to the biomedical specifications for which the medical device was designed.*

Technogym® ensures its own safety standards by means of the following tools and activities:

- *ISO 9001/2000 certification of the company;*
- *Certification of the device in compliance with medical regulations 60601-1 and 60601-1-2;*
- *Electrical testing of each device manufactured, according to the provisions of the aforementioned standards;*
- *Training of technical staff who perform technical service;*
- *Use of checked and tested original Technogym® spare parts for all service operations;*
- *CE Declaration of Conformity.*

11.1. ELECTRICAL SAFETY TEST

Based on the risk analysis carried out by the After Sale department regarding installation and technical service, it is still necessary to use a tester to perform a safety test on the grounding ring. This test must ensure a continuous earth connection (*resistance less than 4Ω (Ohm)*) between the grounding pole of the mains lead (*connected to the machine*) and the points listed below:

Continued in following page...

First of all, check the resistance on the tester probes is approximately 0Ω .



11.2. MECHANICAL TESTING OF SECURITY

11.2.1. CHECKING THE ASSEMBLY OF THE TRANSMISSION AND LEVERS SYSTEMS

Check the correct assembly of the: levers, footboards and brake components. In particular, make sure that:

1. *The footboard and the levers have been correctly mounted and aligned. Try to exercise on the machine and check the movement is smoothly and do not produce noise;*
2. *The shafts, the pulleys and all the components of the mechanism have been correctly mounted and aligned. Try to exercise on the machine and check the movement is smoothly and do not produce noise;*
3. *The brake winding components are correctly assembled. That the pedalling action is always smooth and silent, even at high effort level.*

11.2.2. CHECKING THE ASSEMBLY OF THE GUARDS

Check the assembly of the machine guards, making sure that:

1. *They are all in place and correctly secured so that no parts of the machine are left exposed that may cause injury to the user.*

11.3. START-UP CHECK

Following installation and after every technical intervention on the machine, plug it into a power outlet, set the power switch to ON.

On power-up the machine performs a self test of the upper and lower assemblies. At the end of this the machine goes into standby, awaiting a keyboard command.

To check the correct operation of the machine:

1. *Get on the machine;*
2. *Begin exercising;*
3. *Check that the displayed speed varies accordingly;*
4. *Check that the exercise resistance varies when the “+” and “-” keys and the Fast-Track are pressed and the effort level change from 1 to 25;*
5. *Put on the heart rate meter and check that the machine correctly reads the heart rate value;*
6. *Grasp the sensors and check that the machine correctly reads the heart rate value.*

11.4. LIST OF CRITICAL SPARE PARTS

Technogym medical devices are identified by “Serial N” plates that allow them to be tracked throughout the useful life-span of the device. Just as for products, there is also a list of so-called **CRITICAL** components which, through the SN, must be guaranteed as traceable.

The list of these critical components is shown in the table below:

Code	Component
<i>R0006668XX</i>	<i>Brake Board</i>
<i>0WR00503XX</i>	<i>Solenoid assembly</i>
<i>R0003767XX</i>	<i>Display Board 700</i>
<i>R0003778XX</i>	<i>Display Board 500</i>
<i>0WQ00060XX</i>	<i>C-Safe Board</i>
<i>0WR00633XX</i>	<i>Cardio Receiver HR/HS</i>
<i>N0000034XX</i>	<i>Cardio Receiver HR</i>
<i>W0005566XX</i>	<i>Schuster socket</i>
<i>0WR00598XX</i>	<i>N. 2 ferrites RKCF-10-A5 RICHCO</i>
-	<i>Display program – SW version</i>
-	<i>Brake board program – SW version</i>

Note:

XX = Baan Revision

YY = Languages

If a critical component listed in this table is replaced during a repair, maintenance or refurbishment, this fact must be **noted** in the **SERVICE REPORT**, by recording the **tracking information** for the new component.

12. SCHEDULED MAINTENANCE



To keep the machine in perfect working order and forestall possible problems it is necessary to carry out the scheduled maintenance operations described below. The maintenance operations can essentially be classified according to the type of service and to who they need to be performed:

- **ORDINARY maintenance operation:**
The ORDINARY maintenance operations can be performed by the club manager. They do not require any kind of technical knowledge, they only consist of simple external cleaning, for the purposes of general hygiene.
- **EXTRAORDINARY maintenance operation:**
*The EXTRAORDINARY maintenance operations have to be performed by a **TG qualified technician** specially trained by Technogym. They consist of the set up, the start up, all the inspections and service operations and the adjustments the machine can need to guarantee a good state of wear and the proper functioning conditions.*

12.1. ORDINARY MAINTENANCE OPERATION

12.1.1. SETTING UP THE OPERATION (DAILY)

1. Turn off the machine by placing the switch in position 0 (OFF).
2. Unplug the mains lead from the wall outlet.

12.1.2. EXTERNAL CLEANING OPERATIONS (DAILY)

1. Using a cloth moistened with a neutral detergent (non acidic), clean the entire machine, taking care not to rub too vigorously, especially on the keys of the display.

 **Never spray the cleaning product directly on the machine.**



WARNING: do not use alcohol, petrol or other chemical products.

12.1.3. INTERNAL CLEANING OPERATIONS (MONTHLY)

1. Turn off the machine by placing the switch in position 0 (OFF).
2. Unplug the mains lead from the wall outlet.
3. Open the motor guard.
4. Use a vacuum cleaner to clean the interior, paying particular attention to the tread belt motor and the electronic circuit boards.



WARNING: when carrying out these operations, be careful not to damage the cables.

5. Move the machine and clean the floor underneath using a vacuum cleaner.

12.1.4. COMPLETE OPERATION (SIX-MENTHLY)

1. To check that the switch, the tool maintains the reset procedure
2. To check the correct operation of the machine, get on the machine:
 - *Press the “Quick Start” key to begin the exercise and check that the tread belt motor starts;*
 - *Press the Fast Track and check that the machine change intensity of exercise;*
 - *Put on the heart rate meter and check that the machine correctly reads the heart rate value;*
 - *Grasp the HS and check that the machine correctly reads the heart rate value.*

12.2. EXTRA-ORDINARY MAINTENANCE OPERATIONS

12.2.1. CHECKING THE WORKING CONDITIONS

1. Check that the machine is connected directly to the wall outlet, without any extension cords, and that the outlet is correctly earthed.
2. Using a multimeter, check that the machine earth node is correctly connected to earth.

12.2.2. CHECKING THE OPERATION OF THE CARDIO RECEIVER

1. Using a separate heart rate monitor, put on the transmitter band and check that the machine and the separate monitor both measure the same heart rate, and that when the band is disconnected the machine does not receive any signal.
2. Using a heart rate frequency simulator, check that the machine detects variations in the heart rate.

12.2.3. CHECKING THE OPERATION OF THE HAND SENSOR RECEIVER

1. Using a separate heart rate monitor, grasp the hand sensors and check that the machine and the separate monitor both measure the same heart rate, and that when the sensors are released the machine does not receive any signal.

12.2.4. CHECKING THE AMOUNT OF PLAY ON THE BALL JOINTS

1. Check the amount of play on the ball joints. If any anomalies are found call in the authorized Technogym Technical Service.

12.2.5. CHECKING THE WEAR OF RUBBER PARTS

1. Check the state of wear of the rubber components. Replace if there are evident signs of wear.

12.2.6. CHECKING THE BELTS

1. Check the state of wear of the belts, using the pulley to turn it by hand, paying special attention to the edges and the inner part. Replace if there are evident signs of wear.
2. Also check the tension of the belts.

12.2.7. CHECKING THE PLAY OF THE LEVER AND PEDAL GROUP

1. Choose a manual training session with difficulty level 1. Step onto the pedals and start using the machine, moving the weight of your body backward and forward, to the right and left. Check whether the lever and pedal group follows these shifts in body weight with an excessive amount of play. If this is the case, replace the lever or pedal group.

12.2.8. CHECKING THE DISPLAY

1. Check the operation of all the keys on the keyboard.
2. Check the operation of all the LEDs and the buzzer.
3. Check VISIO Touch Screen calibration.

12.2.9. CHECKING THE WIRING AND CONNECTIONS

1. Check the condition of all the cables:
 - *External conditions;*
 - *Possible rusting of the connectors;*
 - *Electrical continuity of the individual wires;*
 - *Isolation of the individual wires toward ground.*
2. Repair and/or replace any non-conforming wires. Check the condition of the fuses using a tester.

13. APPENDIX

13.1. PASSWORD MENUTABLE

The configuration menus available and their corresponding access passwords are shown below:

PASSWORD LIST				
Assistenza Service	2501 VisioWEB	2501	Configurazione tecnica; Technical configuration;	LED VISIO
		2502	Upload/ Network page;	VISIO
		2503	Scrivi il Serial Number; Write Serial Number;	VISIO
		2512	Accesso ambiente Windows; Windows screen;	VISIO
		2612	Selezione tipo macchina; Machine type selection;	VISIO
		2411	Troubleshooting;	LED VISIO
Utente User	2406 VisioWEB	2404	Configurazione IP-TV; IP-TV configuration;	VISIO
		2405	Configurazione IP- Radio; IP-Radio configuration;	VISIO
		2406	Configurazione Utente + letture Serial Number; User Configuration + Serial number reading;	LED VISIO
		2407	Sintonizzazione canali Analogici e Digitalli TV; Analog and Digital TV channels tuning;	VISIO
		2408	Sintonizzazione canali Analogici e Digitalli Radio; Analog and Digital Radio channels tuning;	VISIO
		2409	Calibrazione Touch Screen; Touch Screen calibration;	VISIO
		2412	Menù personalizzazione profile utente; Training profile menù (to add and customize personal profiles);	LED VISIO
		2413	Configurazione Network; Network configuration;	VISIO
		-	Configurazione VISIOWEB Bookmarks; VISIOWEB Bookmarks configuration;	-

13.2. REQUIRED TOOLS

The following tools are required for carrying out the various disassembly, adjustment and maintenance action on the machine:

- *Small Phillips screwdriver;*
- *Medium Phillips screwdriver;*
- *Big Phillips screwdriver;*
- *17mm wrench;*
- *3mm hexagonal wrench;*
- *4mm hexagonal wrench;*
- *5mm hexagonal wrench;*
- *6mm hexagonal wrench;*
- *8mm hexagonal wrench;*
- *10mm hexagonal wrench;*
- *25mm Racket wrench;*
- *27mm Racket wrench;*
- *10mm socket wrench;*
- *Snap ring pliers;*
- *Bicycle pedal extractor.*

 **You can order a complete set of hexagonal wrenches consisting of 7 pieces: 2, 2.5, 3, 4, 5, 6 and 8mm. The code to be used is R0003677AA.**

- *Excite Test box (cod.H0003180AA-UK).*



TECHNOGYM S.p.A.

Via Calcinaro, 2861

47521 Cesena (FC)

ITALIA

Tel.: +39-0547-56047

Fax: +39-0547-650150

e-mail: service@technogym.com