

Recline Forma

User manual



Contents

1	Important safety instruction.....	3
2	Personal safety.....	5
3	Equipment identification	7
4	Technical data	8
5	Description of the equipment	9
6	Accessories	10
7	Safety devices and warnings.....	11
8	Place of installation	12
9	Moving the equipment	13
10	Levelling.....	14

11	Electrical connection.....	15
12	Switching on and off.....	16
13	Maintenance	17
	13.1 Changing the fuses	19
14	Easily solved problems	20
15	Technical Support Service	22
16	Storage.....	23
17	Scrapping.....	23
18	Monitoring the heart rate.....	24
19	Using Recline Forma.....	26

1 Important safety instruction

You should always consult with a qualified and licensed medical professional or healthcare practitioner before starting any nutritional, diet, stretching or exercise program. You are advised to investigate and inform yourself about any health related actions and choices you make.

Recline Forma is intended for commercial use.

Please read all instructions before using the equipment. These instructions were written to ensure your safety and to protect the unit.

When using an electrical appliance, basic precautions should be always followed, including the following.

Danger

To reduce the risk of electric shock, always unplug the unit from the electrical outlet immediately after using and before cleaning or performing any maintenance tasks.

To reduce the risk of burns, fire, electric shock or injury to person, take the following precautions.

- The equipment should never be left unattended when plugged in. Unplug from outlet when not in use, before cleaning it, and before putting on or taking off electrical parts.
- Do not allow children unsupervised access to the equipment; parents and guardians must assume responsibility for the children in their care and avoid the occurrence of situations or usage for which the equipment was not designed. Children must be closely supervised when using the equipment, with careful attention paid to their mental and physical development. The equipment must under no circumstances be adapted or used as a toy.
- Close supervision by qualified personnel is necessary when the equipment is used by or near invalids or disabled persons.
- Use the equipment only for its intended use as described in the user manual. Only perform the exercises for which the equipment has been designed, following the instructions given in the manual. Any other use is to be considered improper and therefore dangerous.
- Do not use attachments not recommended by Technogym.
- Never operate the equipment if it has a damaged cord or plug, if it is not working properly, if it has been dropped or damaged, or dropped into water. In this case, contact the Technogym Technical Support service.
- Do not carry the equipment by supply cord or use cord as handle.
- Keep the cord away from heated surfaces.
- Keep hands away from moving parts.

- Never drop or insert any object into any opening.
- Do not use outdoors. Do not leave the appliance outdoors, exposed to the elements (rain, sun, wind, etc.). Do not expose the appliance to water jets.
- Do not operate where aerosol (spray) products are being used or where oxygen is being administered.
- To disconnect, turn all controls to the off position, then remove plug from outlet.



Warning

Connect the equipment to a properly grounded outlet only. See grounding instructions.

SAVE THESE INSTRUCTIONS

2 Personal safety

Before starting any exercise you are advised to read the whole manual thoroughly and get to know the equipment's controls.

Recline Forma can be used only after having a **medical check-up** for the specific type of exercise to be carried out and in compliance with Technogym's stated use conditions.

Before starting a workout program, consult a doctor for advice on any limits to observe when using the equipment.

Persons with specific physical complaints may use the equipment only under the strict supervision of a doctor specialised in that particular area.

If you feel ill during the workout (dizziness, chest pains, etc.), **stop exercising immediately** and consult a doctor.

If the message "HIGH HEART RATE" appears during the exercise, your heart rate is too high and you should **slow** the exercise **down**.

At the beginning of each exercise, make sure you are in **the correct position**, and that none of the parts of the equipment are in your way.

Choose suitable exercises for your physical characteristics and state of health, starting out with light loads.

Do not overexert yourself or work to exhaustion. If you feel any pain or abnormal symptoms, stop your workout immediately and consult your physician.

Incorrect or excessive exercise may cause physical harm.

Wear proper exercise clothing and shoes during a workout, no loose clothing. Tie long hair back. Keep garments or towels away from moving parts.

During use people must remain at a safe distance.

Do not use the equipment in presence of small children or pets.

Completely assemble the equipment before using it. Check the unit before each use. Do not continue to operate the equipment when it is not working properly.

Assemble and operate the equipment on a solid, level surface.

Keep all electrical components, such as the power cable and I/O switch, away from liquids to prevent shock.

Maintain the equipment in good working condition. If there are signs of wear, contact the Technogym Technical Support service.

Do not attempt to service the equipment yourself other than the maintenance instructions found in the manual.

Do not set anything on the casing or control panel.

The equipment **must not** be placed close to heat sources or close to sources of electromagnetic waves (e.g. televisions, electrical motors, aerials, cellphones, etc.).

Although the equipment has been designed and built in accordance with health and safety requirements, there are some zones in which there are unseen hazards. You must be very careful about possible upper and lower limb crushing hazards.

 **Warning**

Technogym s.p.a. will be held responsible for its equipment only if the following precautions are observed:

- **the equipment must be used as specified;**
- **the User manual must be read thoroughly throughout;**
- **the place of installation must meet the requirements stated in the User manual;**
- **the electrical system must conform to the standards and legal requirements in the country of use;**
- **the installation, maintenance and setting must be done by qualified Technogym staff or persons authorised by Technogym;**
- **suitable clothing must be worn;**
- **towels and other items must not be put on the equipment.**

Technogym is not responsible for any damages due to any failures or damage caused by unauthorized service, misuse, accident, negligence, improper assembly or installation, debris resulting from any construction activities in the product's environment, rust or corrosion as a result of the product's location, alterations or modifications without Technogym's written authorization or for failure on your part to use, operate and maintain the products as set out in this User Manual.

3 Equipment identification

The equipment identity label gives the present information:

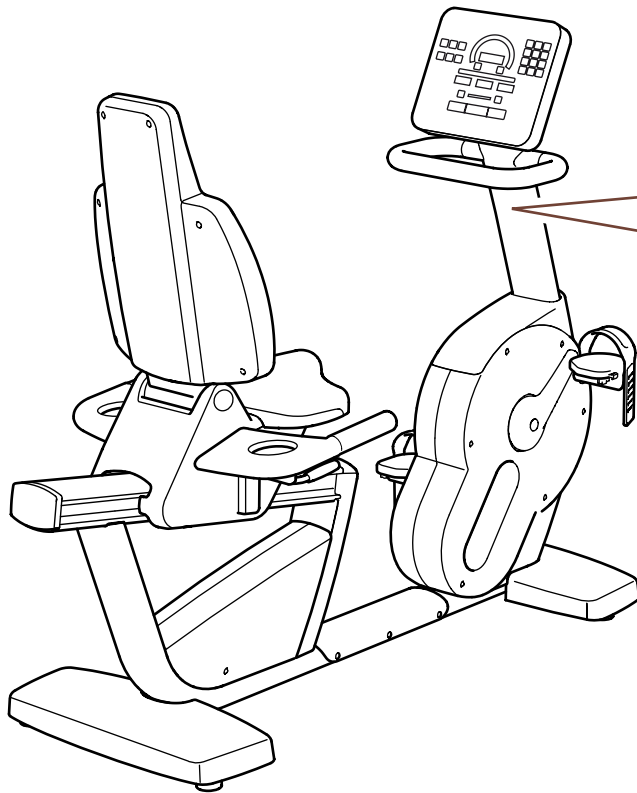

- Manufacturer's name and address
- Name of product
- Electrical specifications
- Equipment classification
- Certification marks
- Serial number and date of manufacture
- Product code

4 Technical data

Recline Forma	
Power supply	100÷240 Vac 50/60 Hz
Max power input	100 VA max
Fuses	2 x 3.15 A (F)
Weight of equipment	81 kg (178 lb)
Maximum user weight	180 kg (397 lb)
Time	0÷999 min ± 1%
Distance	0÷99,99 km ± 5% (0÷99,99 mi ± 5%)
Braking power	40÷500 W ± 10%
Protection grade	IP 20
Operating temperature	from +5°C to +35°C
Electrical isolation class	Class I
Marks and certificates	CE

Ordinary appliance, not waterproofed.

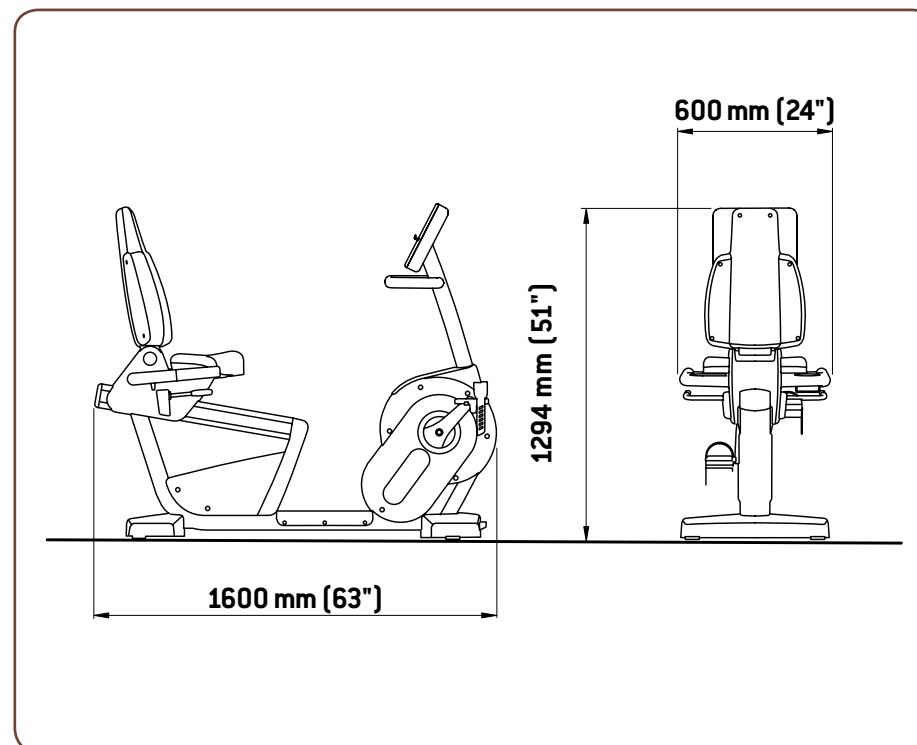

5 Description of the equipment

- 1 - **Control panel:** controls all available functions, from setting up workout programs to viewing messages and related workout information.
- 2 - **Handlebar:** can be held by the user to get on and off the equipment more easily.
- 3 - **Saddle:** this is equipped with a comfortable backrest that supports the back.
- 4 - **Pedals:** with adjustable straps for a more stable foot position.
- 5 - **Bases:** support the equipment frame and components.
- 6 - **Side handles:** these can be grasped during the workout to help improve posture.
- 7 - **Bottle-holder:** for standing the water bottle or other useful items on during the workout.
- 8 - **Object holder:** for placing magazines, books or tablets and other electronic devices. Tablets can be firmly fixed as shown in the figure.

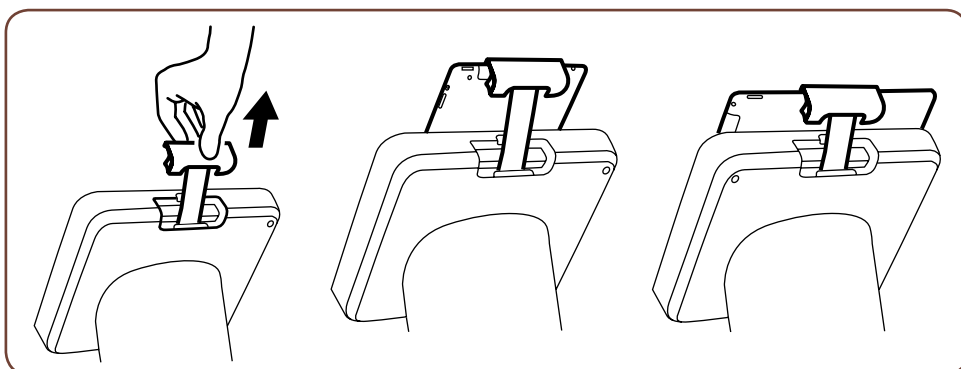
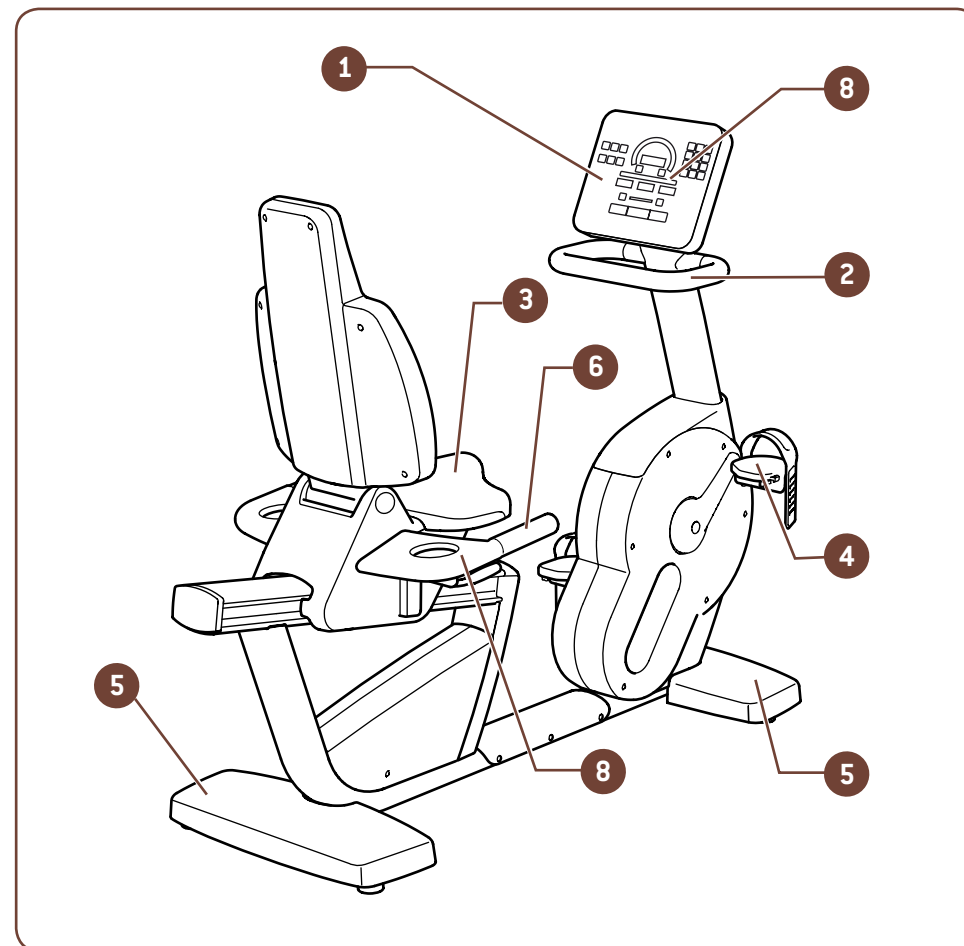

6 Accessories

The supplied kit includes the following accessories:

- 1 - Set of wrenches
- 2 - Chest band with transmitter for heart rate monitor
- 3 - User manual
- 4 - Warranty certificate
- 5 - Power supply cable
- 6 - Spare fuses 2 x 3.15 A (F)
- 7 - Cloth for cleaning

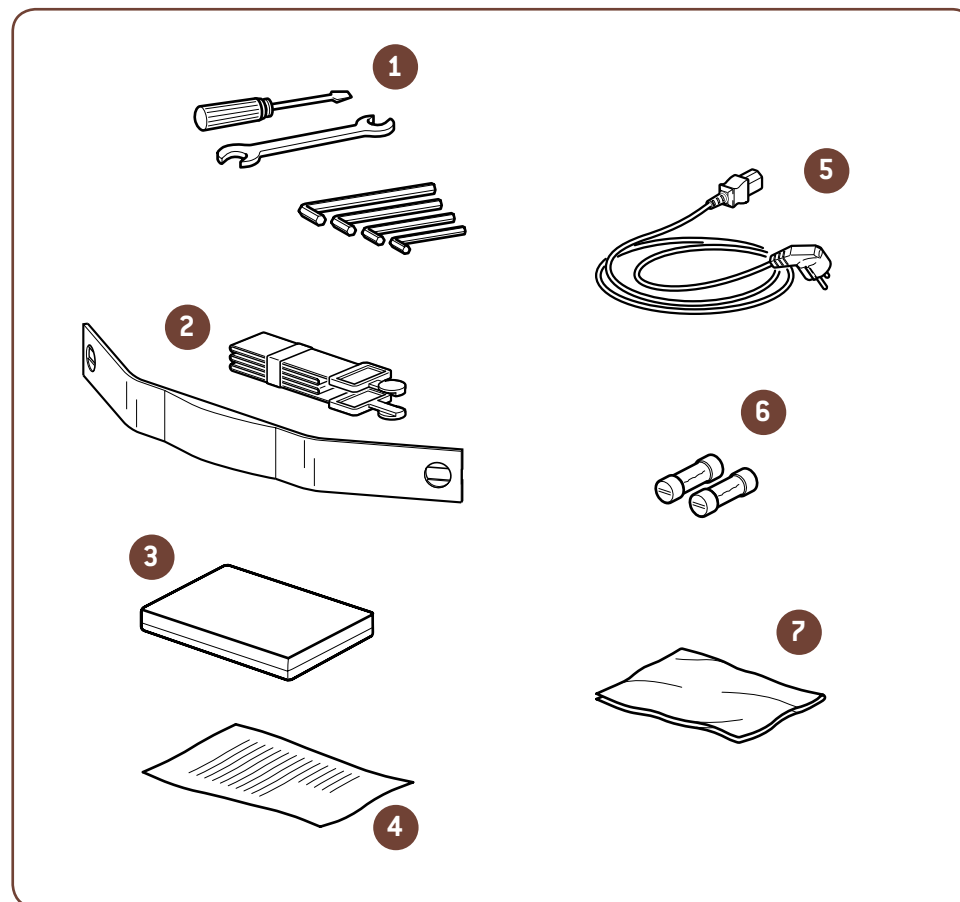

7 Safety devices and warnings

- A - Fixed guard:** guards against access to the inside of the equipment.
- B - Fuses:** protect the equipment's electrical parts. When the current reaches an excessive value, the fuses melt thus protecting the internal electronics.
- C - Main switch:** turns the equipment's power on and off.
- D -** The label affixed to the frame under the control panel states the equipment electrical specifications.
- E -** The label for attachment to the power supply cable states the electrical specifications for the cable.

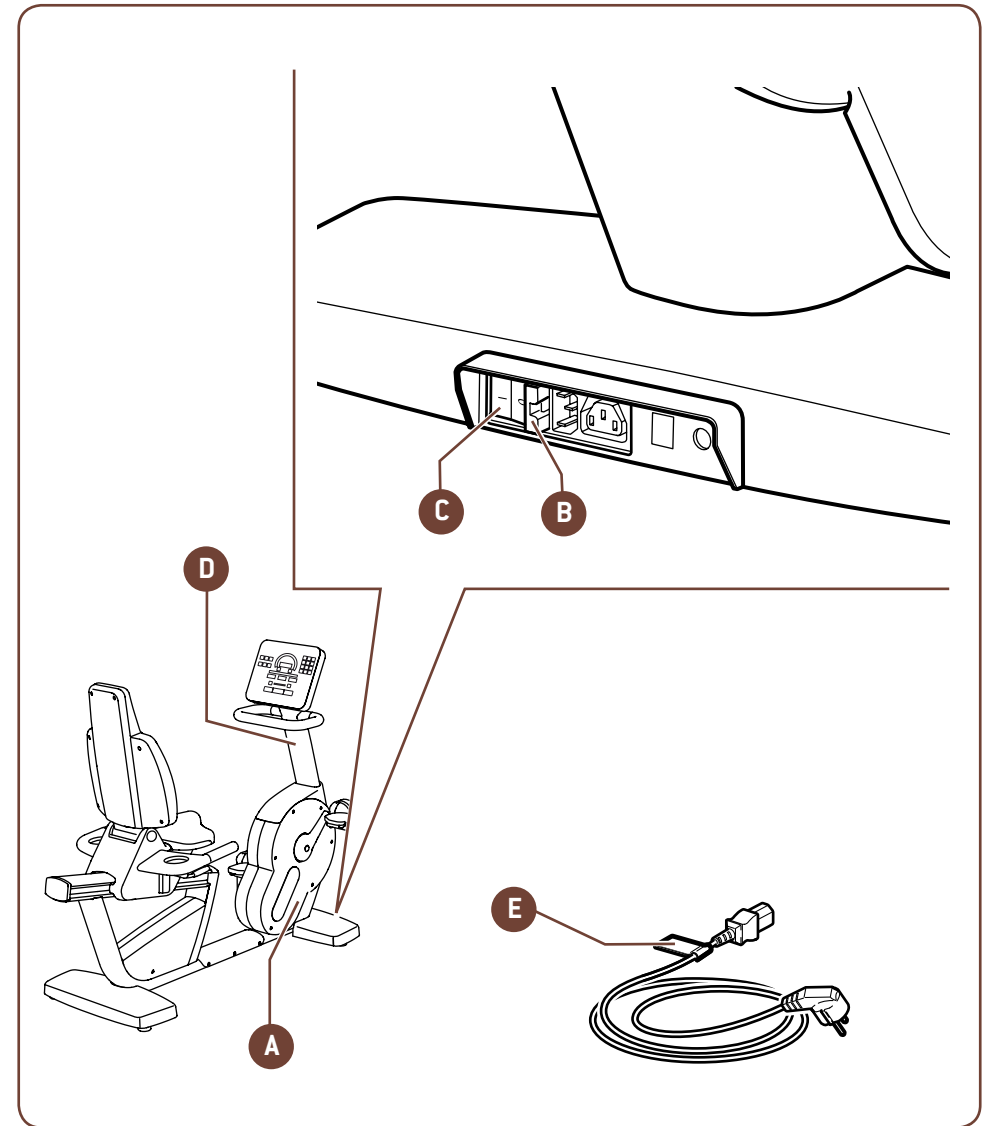

8 Place of installation

To guarantee safe, comfortable and effective use of the equipment, the place of installation must comply with certain specific requirements; in particular, before choosing where to install the equipment it is recommended to check the following:

- the **temperature** is between +10°C and +25°C;
- enough air is circulating to keep **humidity** during exercise to between 20% and 70%;
- the **lighting** is good enough to make the area safe and relaxing place to exercise in;
- there is a safety area of **free space** around the equipment;
- the floor is flat, stable and vibration-free, and strong enough to bear the weight of the equipment plus user.

The place of installation must comply with all binding regulations.



Warning

Do not expose the equipment to direct sunlight.

Do not install the equipment in areas with high humidity levels, for example close to swimming pools, whirlpools or saunas.

9 Moving the equipment

Warnings

**Move the equipment with great care to avoid it tipping over.
After moving the equipment always check that it is level in order to
guarantee the correct working.**

The equipment has two fixed wheels.

To move the equipment, lift it up slightly, as shown in the illustration, and push it forwards and backwards.

If flooring conditions prevent use of the wheels, normal moving procedures must be employed.

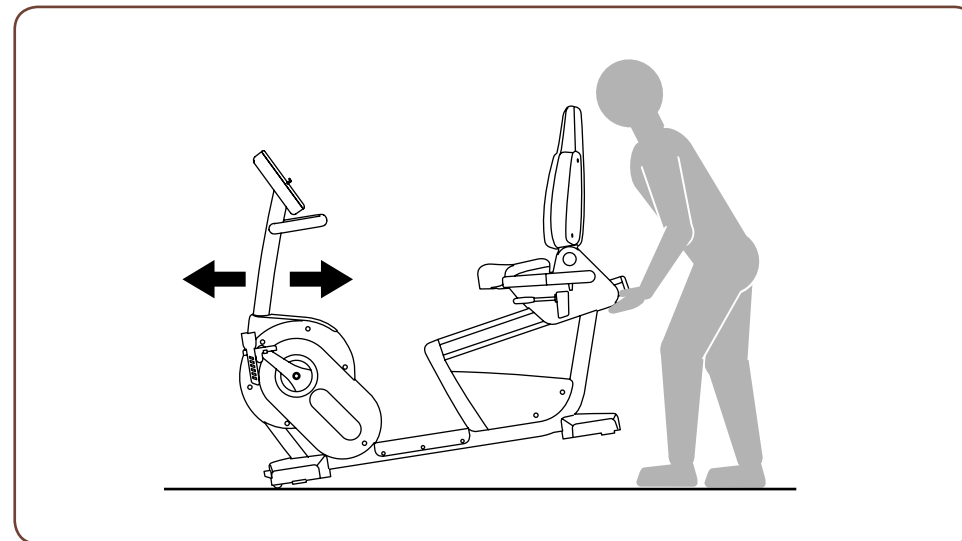

10 Levelling

Check that all the feet are resting on the floor. If they are not, the equipment must be levelled.

Loosen the locknut **(B)**.

Unscrew or screw the foot **(A)** until the frame is stable.

After adjusting tighten the locknuts **(B)**.

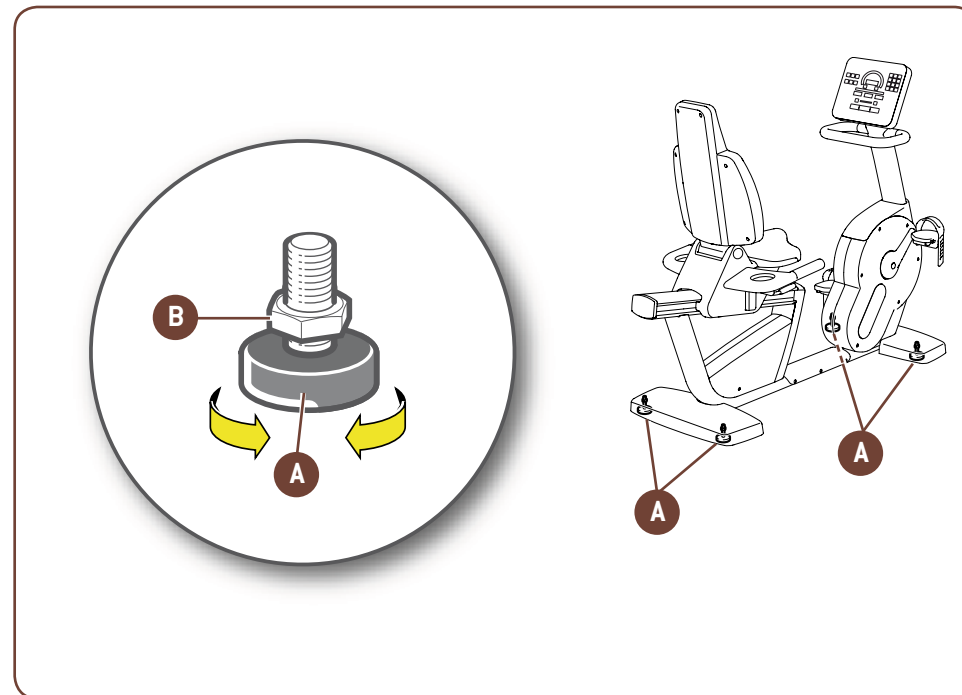

11 Electrical connection

Before connecting the equipment to the mains power supply, ensure that the electrical installation complies to binding regulations. Check the mains power supply specifications on the equipment identity label.

Warnings

- The wall socket must be located in a place where the plugging and unplugging can be done easily and safely.**
- When plugging in, the main switch on the equipment must be in the 0 position (i.e. the equipment must be switched off).**
- Check the state of the power supply cable periodically.**

Plug the power cable first into the equipment socket and then into the wall socket.

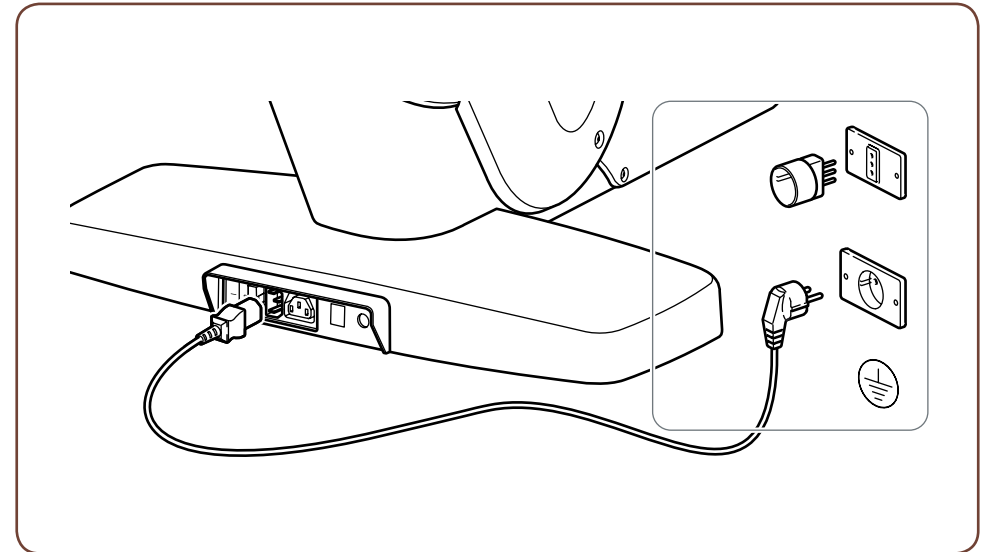

The product must be grounded. If it should malfunction or breakdown, grounding provides a path of least resistance for electric current to reduce the risk of electric shock. The product is equipped with a cord having an equipment-grounding conductor and a grounding plug. The plug must be plugged into an appropriate outlet that is properly installed and grounded in accordance with all local codes and ordinances.

DANGER

- The power supply socket must be grounded . If not, a ground connection must be installed by a qualified electrician before connecting the equipment to the electricity mains.**
- Improper connection of the equipment-grounding conductor can result in a risk of electrical shock. Check with a qualified electrician or serviceman if you are in doubt as to whether the product is properly grounded. Do not modify the plug provided with the product; if it will not fit in the outlet, have a proper outlet installed by a qualified electrician.**

12 Switching on and off

To turn the equipment on, switch the main switch to the “I” position (on) .

After a quick system check (reset), the equipment is ready for use.

To turn the equipment off, switch the main switch to the “0” position (off).

The equipment must be switched off only at the end of the exercise, when in standby.

If the equipment is not expected to be used for a long time, as well as turning it off you should also pull the plug out of the wall socket.

Warning

The switch is for turning the equipment on and off but does not isolate it completely from the mains voltage, even in the “0” position (off). For complete isolation you must unplug the power supply plug.

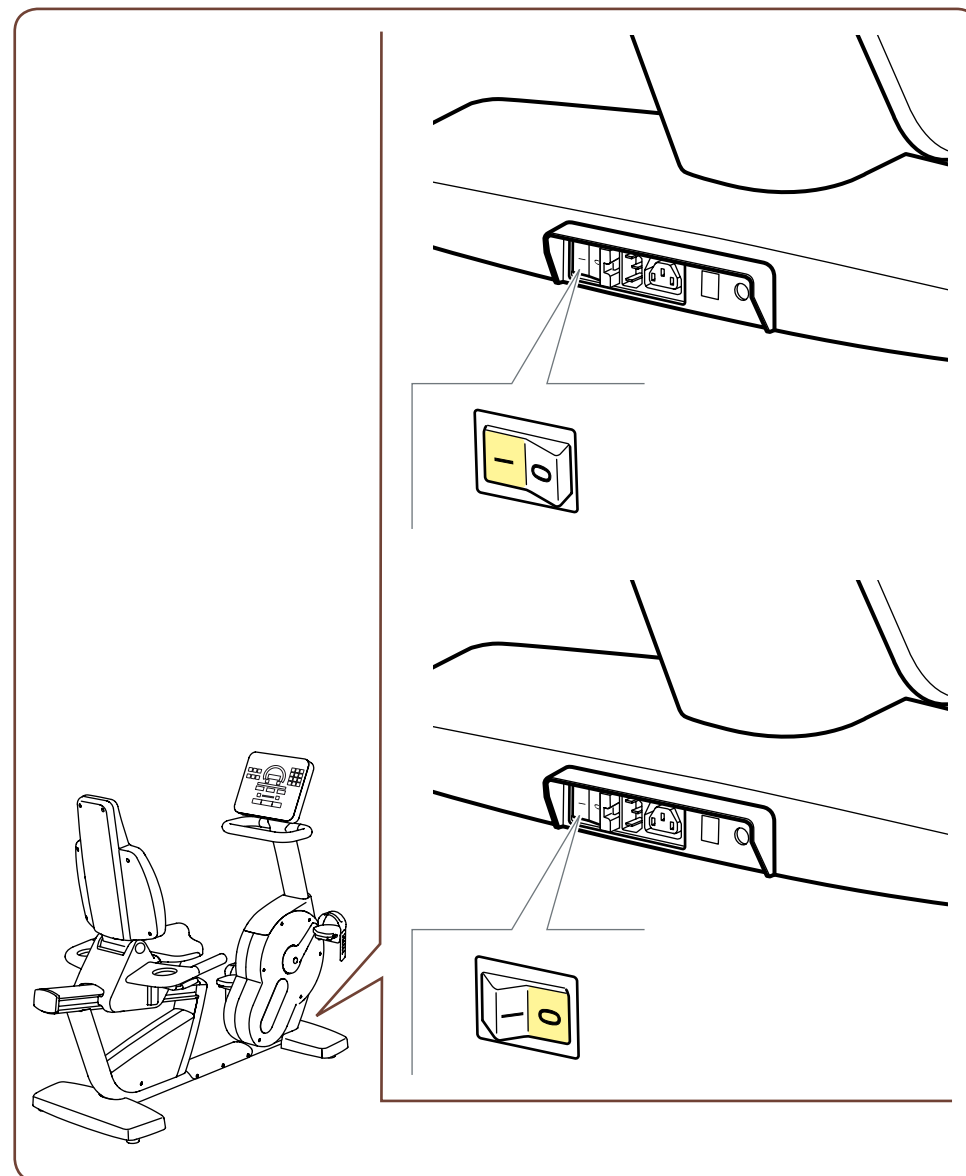

13 Maintenance

Warnings

The safety of the equipment is assured only on the condition that it is carefully inspected every two weeks for any signs of damage and/or wear. Replace defective and worn components immediately, or alternatively remove the equipment from service.

For maintenance actions not described in this manual, call in the Technogym Technical Service.

Cleaning and looking after the equipment

The equipment should always be kept clean and free of dust, in accordance with normal hygiene and sanitary rules.

To clean the **control panel**, proceed as follows:

- turn the equipment off by switching the switch to **0**;
- unplug the equipment power cable from the wall socket;
- clean the control panel with a damp, but not wet, cloth.

Every week, clean **the equipment completely**:

- with the equipment turned off, clean the external parts with a damp sponge;
- move the equipment to one side so that you can vacuum clean underneath it.

Do not use chemicals or solvents. Do not use abrasive products on polished parts.

Warning

Do not rub too hard on the control panel.

Checks

Warnings

The routine maintenance, adjustment and lubrication jobs must be performed by the Technogym Technical Support Service.

Before starting any job, turn the equipment off by switching the switch to the 0 position and unplug the power cable from the wall socket.

Pos.	Description	Type of intervention	Frequency
A	Transmission belt	Check state of wear	Six-month
B	Pedals	Check play	Six-month

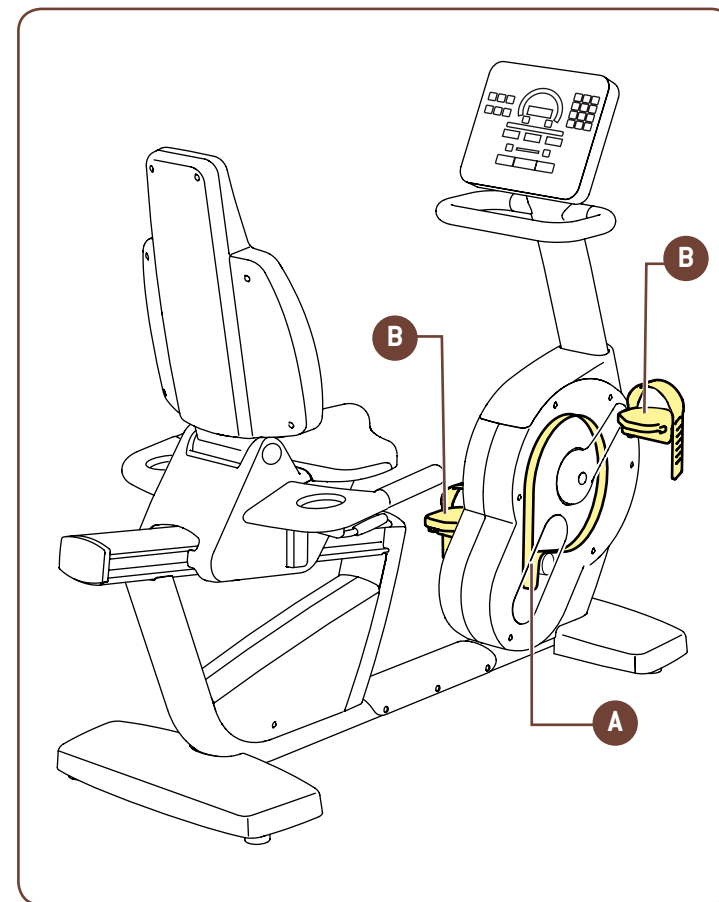

13.1 Changing the fuses

Warnings

The fuses must be changed by the Technogym Technical Support Service.

Before changing the fuses, switch the equipment off by switching the switch to 0 and unplug the power cable plug from the wall socket.

Remove the fuse holder, to the right of the switch, by pushing the lever.

Replace the blown fuse with the new one, as supplied.

Fit the fuse holder back into its housing, making sure it clicks in properly.

Warning

If no more of the supplied fuses are available, use a certified fuse with identical electrical specifications for the replacement.

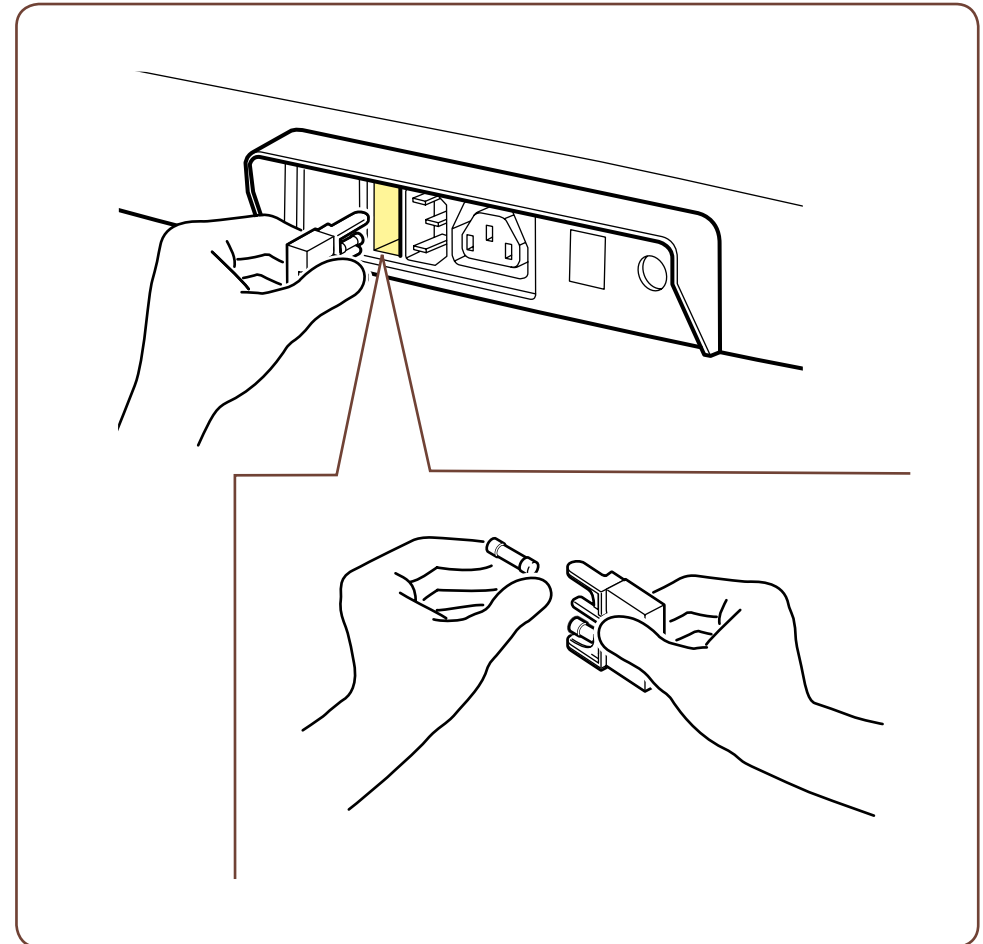

14 Easily solved problems

The following table lists a series of problems that may arise during normal use of the equipment. If the solutions given don't solve the problem, or if the problems are different, ask for help from the Technical Support Service.

Problem	Cause	Remedy
Equipment doesn't switch on	Power supply cable not plugged in	Plug the power supply cable into the wall socket
	Mains power failure	Check the power supply in the mains socket in question by plugging in another appliance that definitely works
	Power supply cable damaged	Contact the Technogym Technical Support Service
	Power supply cable connector not plugged into equipment	Plug the connector in
	The main switch is off	Switch on the main switch
	Burnt-out fuse	To replace the blown fuse with a spare contact the Technogym Technical Support Service

Problem	Cause	Remedy
Excessive noisiness	Equipment not properly levelled	Check the position and level with the adjustment feet
	Damaged bearingd	Contact the Technogym Technical Support Service
	Worn belt	Contact the Technogym Technical Support Service
Data incorrect or unreliable with equipment running	Equipment next to source of radio interference (e.g. electrical domestic appliance)	Move the equipment to another place or move the sources of interference
Problems in reading heart rate	Other transmitters situated nearby	Move the equipment far enough away to stop signal interference (minimum distance between two units cm 80)
	Strong radio interference sources nearby	Find the interference source (e.g. electrical domestic appliance) and move it away or move the equipment
	Worn chest band	Replace the chest band
	Chest band not making proper skin contact	Dampen the inside of the chest band with water



Warning

There are high voltages inside the equipment, therefore the guard must be removed by authorised personnel only; only authorised personnel can carry out internal repairs.

15 Technical Support Service

The Technogym Technical Support Services provides:

- telephone consultation
- information about which services are covered by the warranty and which must be paid for
- on-site servicing
- supply of original spare parts.

Technogym International
Technical support HQ
tel: +39 0547650638
fax: +39 0547650150
email: support@technogym.com

When you contact the Technogym Technical Support Service you must give the following information:

- equipment model,
- date of purchase,
- serial number,
- precise description of the problem.



Warning

Work on the equipment by persons unauthorised by Technogym invalidates the warranty.

Technogym supplies the electrical and wiring diagrams to companies with technical support.

16 Storage

If a long period of disuse is expected, you are advised to store the equipment in the following way:

- in a dry, clean place, covered with a cloth to protect it from dust
- at a room temperature between +10°C and +25°C and relative humidity between 20% and 90%.

For better storage, use the **original packing materials**.

17 Scrapping

Always ensure that the equipment poses no danger to people and do not let children play with it. As a precaution, when the equipment is unused for a long time, unplug it from the mains.

Disposing of the equipment on open ground, in public areas, or in private areas used by the public is prohibited.

The equipment is made of recyclable materials such as steel, aluminium and plastic, which must be disposed of in compliance with urban waste and refuse regulations, contacting a company specialised in urban and environmental sanitation.

Disposing of the chest band

The chest band, which transmits heart rate data, is not made of recyclable materials and therefore must not be disposed of on open ground.

Contact a company specialized in urban and environmental sanitation.

18 Monitoring the heart rate

The equipment is able to measure heart rate trends, by means of a chest band with a Polar T31-type heart rate transmitter.

There must be no more than one transmitter in the reception range: otherwise the receiver may receive different signals at the same time and give incorrect heart readings. If there are several equipment units with heart rate receivers in the same area, the recommended minimum distance between them is 80 cm.

Heart rate readings will not be accurate near electromagnetic radiation sources (TVs, cellphones, etc.).

Should you have any doubts about the accuracy of the readings, contact the Technical Support Service.

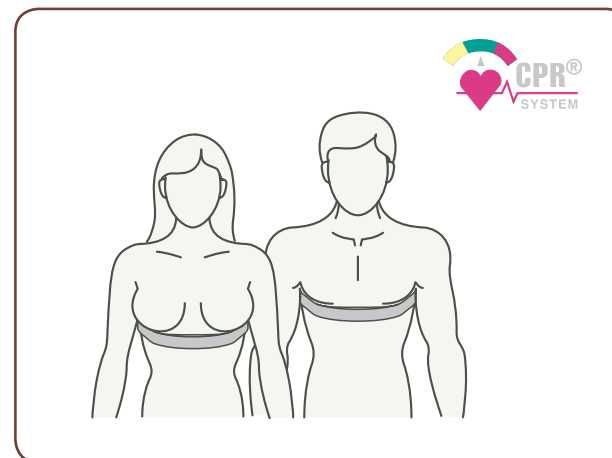

Warnings

During a workout it is very important that your heart rate never goes above 90% of your maximum rate (unless you are an athlete engaged in competitive sport).

The sole function of the heart rate monitor is to display the heart rate during exercise and cannot be used for medical cardiac diagnoses of any kind.

The heart rate shown on the display is purely indicative and cannot be considered absolutely certain.

The following table shows the optimum heart rate levels in relation to age and the goal to be achieved. Theoretical maximum heart rate (100%) is calculated on the basis of age using the formula: $HR\ Max = 207 - 0.7 \times age$ (R. L. Gelish et alii, *Med Sci Sports Exerc.*, 2007 May, 39 (5): 281).

To read the graph, simply find your age on the horizontal axis and scan up the vertical until you reach the 60%, 70% and 90% values.

Aerobic exercise performed at a heart rate **between 60% and 70%** mainly burns fat as an energy source.

When doing aerobic exercise at a heart rate of **70% to 90%** the cardiocirculatory component prevails.

For example, if someone aged 30 wants to burn off fat, the heart rate during exercise should be kept to between 112 (60%) and 131 (70%); if he or she wants to improve cardio-respiratory capacity, the heart rate should be kept to between 131 (70%) and 168 (90%).

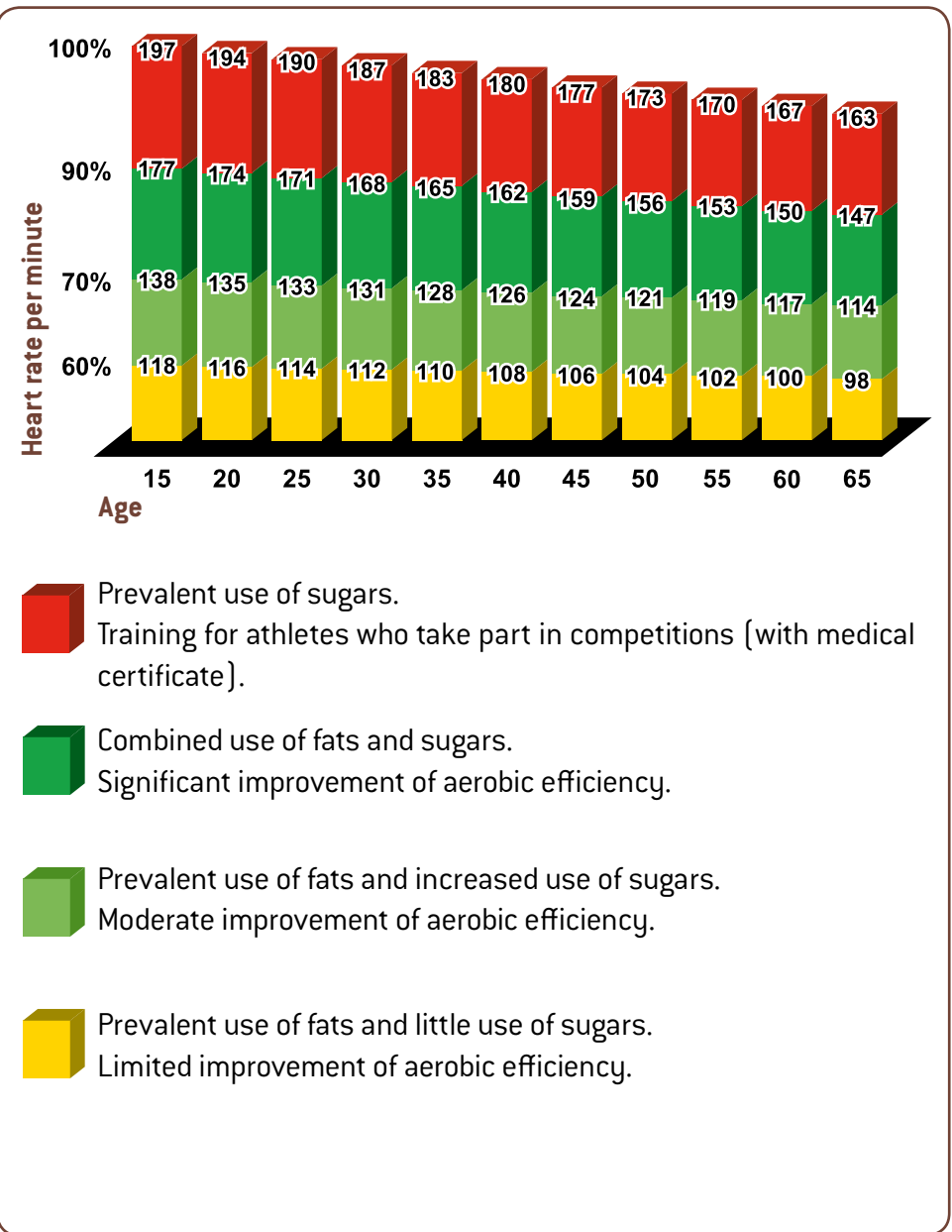

19 Using Recline Forma

Warning

Recline Forma is to be used solely for its intended purpose, i.e. as a cycle ergometer. Any other use of the equipment is to be considered improper and therefore dangerous.

Mount the saddle with your trunk pressed firmly against the backrest. When the pedal is pushed all the way forward, your leg must be almost completely extended.

Any other position, for example with one foot, or with your legs stretched too far or too bent, may cause instability and/or incorrect leg movements, thus causing pain in various parts of your body.

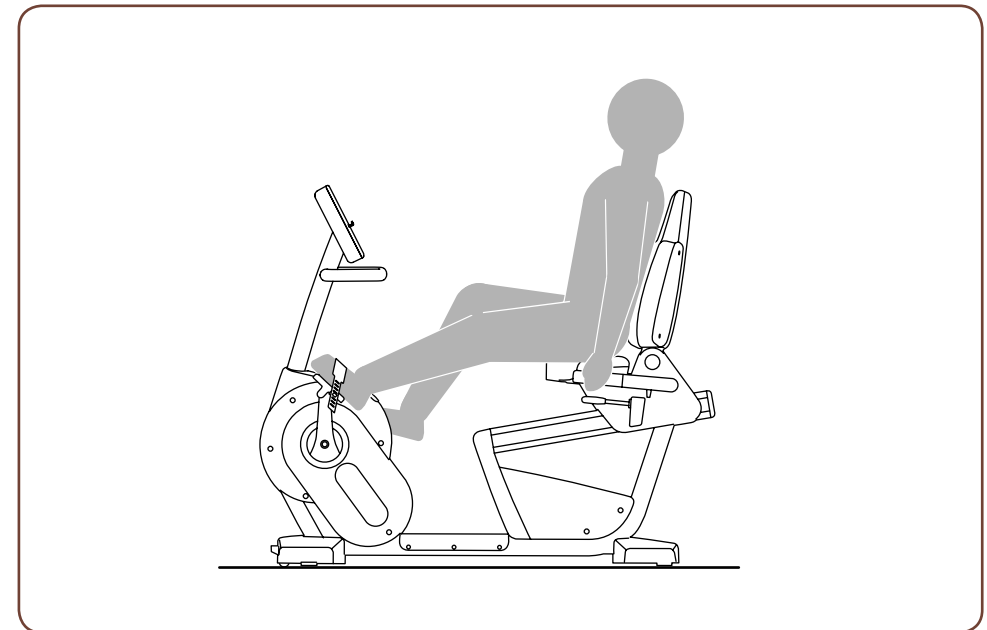

To adjust the pedal straps, pull out the tab and then re-insert it in the correct slot for your foot size.

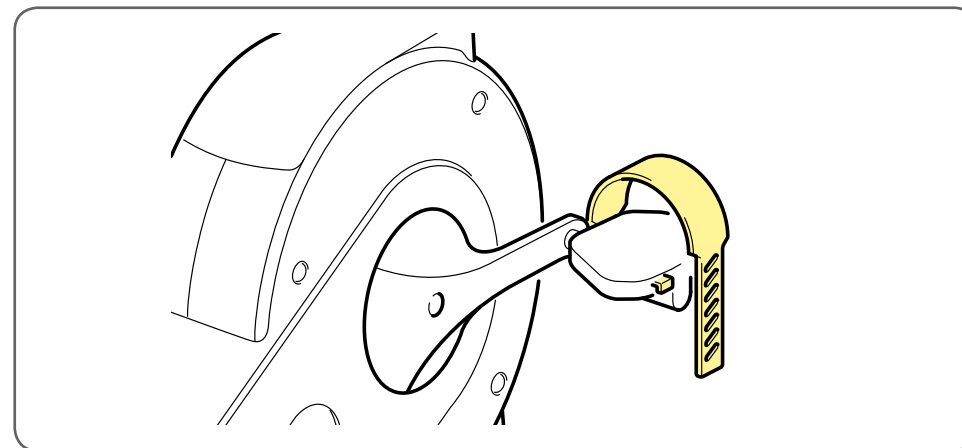

To move the saddle forwards or backwards, lift the lever **(A)** under the seat, on the right side.

To adjust the backrest lift the lever **(B)** under the seat, on the left side.

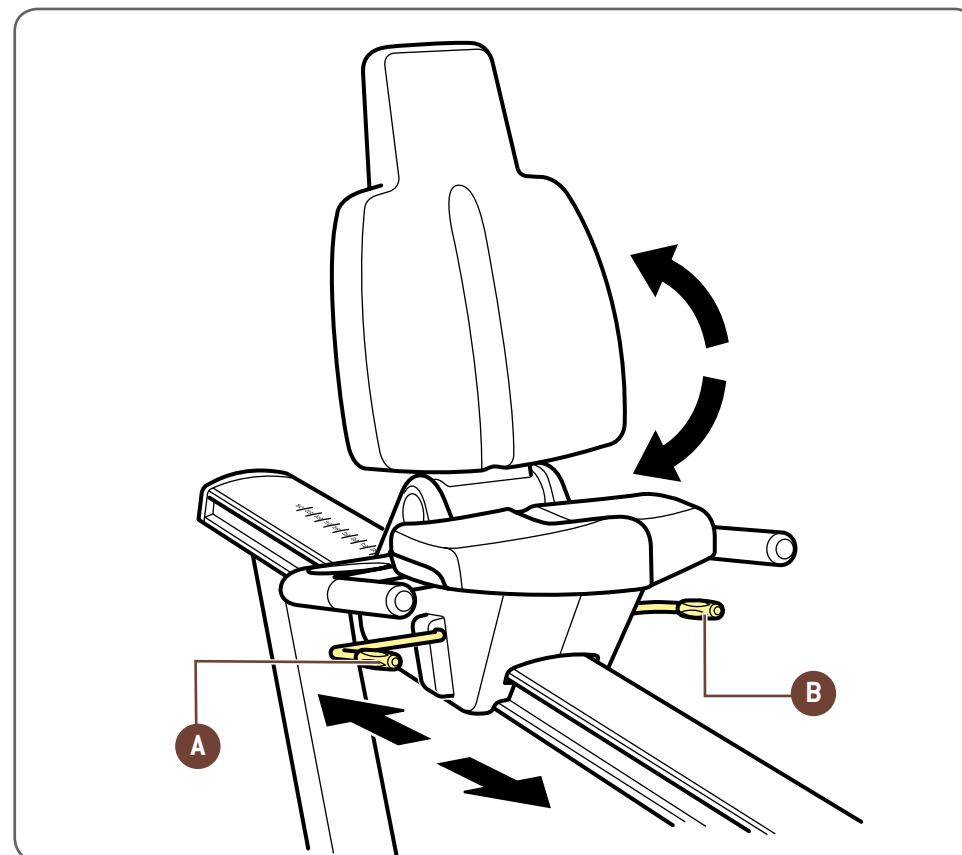

ReclineForma_uk-AB
OSM00750



The Wellness Company

www.technogym.com